

Mesa™ Adhesive Melters
Models M4, M6, M9, and M14

Customer Product Manual
Part 1089887A02

Issued 2/10



NORDSON CORPORATION • DULUTH, GEORGIA • USA
www.nordson.com



Nordson Corporation welcomes requests for information, comments, and inquiries about its products. General information about Nordson can be found on the Internet using the following address: <http://www.nordson.com>.

Address all correspondence to:

Nordson Corporation
Attn: Customer Service
11475 Lakefield Drive
Duluth, GA 30097

Notice

This is a Nordson Corporation publication which is protected by copyright. Original copyright date 2009. No part of this document may be photocopied, reproduced, or translated to another language without the prior written consent of Nordson Corporation. The information contained in this publication is subject to change without notice.

Trademarks

AccuJet, AeroCharge, Apogee, AquaGuard, Asymtek, Automove, Baitgun, Blue Box, Bowtie, CanWorks, Century, CF, CleanSleeve, CleanSpray, ColorMax, Color-on-Demand, Control Coat, Coolwave, Cross-Cut, DispenseJet, DispenseMate, DuraBlue, DuraDrum, Durafiber, DuraPail, Dura-Screen, Durasystem, Easy Coat, Easymove Plus, Ecodyr, Econo-Coat, e.dot, EFD, Encore, ESP, e stylized, ETI, Excel 2000, Fillmaster, FlexiCoat, Flex-O-Coat, Flow Sentry, Fluidmove, FoamMelt, FoamMix, Fulfill, HDLV, Heli-flow, Horizon, Hot Shot, iControl, iDry, iFlow, Isocoil, Isocore, Iso-Flo, iTRAX, Kinetix, LEAN CELL, Little Squirt, LogiComm, Magnastatic, March, Maverick, MEG, Meltex, Microcoat, Micromark, MicroSet, Millennium, Mini Squirt, Mountaingate, MultiScan, Nordson, OptiMix, Package of Values, Pattern View, PermaFlo, Plasmod, Porous Coat, PowderGrid, Powderware, Precisecoat, PRIMARC, Printplus, Prism, ProBlue, Prodigy, Pro-Flo, ProLink, Pro-Meter, Pre-Stream, RBX, Rhino, Saturn, Scoreguard, Seal Sentry, Select Charge, Select Coat, Select Cure, Signature, Slatutterback, Smart-Coat, Solder Plus, Spectrum, Speed-Coat, SureBead, Sure Clean, Sure-Max, Sure Wrap, Tracking Plus, TRAK, Trends, Tribomatic, TrueBlue, Ultra, Ultrasaver, UpTime, u-TAH, Vantage, VersaBlue, Versa-Coat, Versa-Screen, Versa-Spray, Watermark, and When you expect more. are registered trademarks of Nordson Corporation.

Accubar, Advanced Plasma Systems, AeroDeck, AeroWash, AltaBlue, AltaSlot, Alta Spray, AquaCure, ATS, Auto-Flo, AutoScan, Axiom, Best Choice, Blue Series, Bravura, Champion, Check Mate, ClassicBlue, Classic IX, Clean Coat, Controlled Fiberization, Control Weave, ContourCoat, CPX, cScan+, cSelect, Cyclo-Kinetic, DispensLink, DropCure, Dry Cure, DuraBraid, DuraCoat, DuraPUR, Easy Clean, EasyOn, EasyPW, Eclipse, e.dot+, Emerald, E-Nordson, Equi-Bead, FillEasy, Fill Sentry, FlowCoat, Fluxplus, Get Green With Blue, GreenUV, G-Net, G-Site, iON, Iso-Flex, iTrend, Lacquer Cure, Maxima, Mesa, MicroFin, MicroMax, Mikros, MiniBlue, MiniEdge, Minimeter, MonoCure, Multifil, Myritex, Nano, OptiStroke, Partnership+Plus, PatternJet, PatternPro, PCI, PicoDot, Pinnacle, Powder Pilot, Powder Port, Powercure, Process Sentry, Pulse Spray, Quad Cure, Ready Coat, RediCoat, Royal Blue, Select Series, Sensomatic, Shaftshield, SheetAire, Smart, SolidBlue, Spectral, Spectronic, SpeedKing, Spray Works, Summit, Sure Coat, SureFoam, Sure Mix, SureSeal, Swirl Coat, ThruWave, TinyCure, Trade Plus, Trilogy, TrueCoat, Ultra FoamMix, UltraMax, Ultrasmart, Universal, ValueMate, VersaDrum, VersaPail, Vista, Web Cure, and 2 Rings (Design) are trademarks of Nordson Corporation.

Designations and trademarks stated in this document may be brands that, when used by third parties for their own purposes, could lead to violation of the owners' rights.

Table of Contents

Safety	1-1
Safety Alert Symbols	1-1
Responsibilities of the Equipment Owner	1-2
Safety Information	1-2
Instructions, Requirements, and Standards	1-2
User Qualifications	1-3
Applicable Industry Safety Practices	1-3
Intended Use of the Equipment	1-3
Instructions and Safety Messages	1-3
Installation Practices	1-4
Operating Practices	1-4
Maintenance and Repair Practices	1-5
Equipment Safety Information	1-5
Equipment Shutdown	1-6
Relieving System Hydraulic Pressure	1-6
De-energizing the System	1-6
Disabling the Guns	1-6
General Safety Warnings and Cautions	1-7
Other Safety Precautions	1-10
First Aid	1-10
Safety Labels	1-10
Introduction	2-1
Product Description	2-2
Intended Use	2-3
Limitations of Use	2-3
Modes of Operation	2-3
Melter Identification	2-4
Key Components	2-5
Tank	2-6
Pump	2-7
Manifold	2-8
Hose Ports	2-9
Manifold Filter	2-9
Drain Valve	2-9
Pressure Relief Valve	2-9
Air Pressure Regulator	2-10
Control Panel	2-11
Installation	3-1
Installing 400/480 Volt Melters	3-1
Overview	3-1
Additional Information	3-2
Installation Tasks	3-2
Experience of Installation Personnel	3-2
Installation Requirements	3-4
Clearances	3-4
Electrical Power	3-6
Other Considerations	3-6

Unpacking the Melter	3-8
Contents of the Installation Kit	3-8
Customer-Supplied Materials	3-8
Mounting the Melter	3-10
Configuring the Electrical Service	3-11
Connecting Hoses and Guns	3-16
Connecting a Compressed Air Supply	3-18
Connecting a Triggering Device for the Pump Solenoid Valve (10:1 Pump) 3-20	
Setting Up the Melter	3-22
Quick Setup	3-22
Operating Parameters	3-24
Selecting Operating Parameters	3-24
Reading or Editing Operating Parameters	3-24
Setpoint Temperature of the Tank, Hoses, and Guns	3-28
Review Parameter and Setpoint Temperature Changes	3-30
Installing Melter Inputs	3-32
Installing Melter Outputs	3-36
Installing Optional Equipment	3-39
Connecting a Gun Driver, Pattern Controller, or Timer	3-39
Flushing the Melter	3-39
Operation	4-1
Additional Information	4-1
Filling the Tank	4-2
Starting the Melter	4-3
Monitoring the Melter	4-5
Confirm that the Melter is Operating Correctly	4-5
Monitor Component Temperatures	4-6
Monitor Melter Faults	4-8
How F1, F2, and F3 Faults are Handled	4-10
How F4 Faults are Handled	4-11
Adjusting Component Temperatures	4-16
Enter the Melter Password	4-20
Using Melter Function Keys	4-21
Heater Key	4-21
Setup Key	4-21
Seven-day Clock Key	4-22
Standby Key	4-23
Shutting Down the Melter	4-24
Maintenance	5-1
Locking Out External Communications	5-2
Relieving System Pressure	5-2
Flushing a Standard Manifold Filter	5-3
Cleaning a Standard Manifold Filter	5-4
Flushing the System	5-8

Cleaning the Melter	5-17
Cleaning the Tank	5-18
Flush the System	5-20
Troubleshooting	6-1
400/480 Volt Melters	6-1
Safety	6-1
Melter Faults	6-2
Using the Troubleshooting Flow Chart	6-4
Troubleshooting Quick-checks	6-4
Returning the Melter Setup to Factory Settings	6-5
Identifying Electrical Components	6-5
No adhesive output from one or more guns	6-11
Mesa Troubleshooting Charts	6-11
Parts	7-1
Using the Illustrated Parts Lists	7-1
Melter Assembly Part Numbers	7-3
Melter Assembly	7-4
Chassis Assembly	7-8
Chassis Parts, 200–240V or 400/230 Y, M4/M6/M9	7-8
Chassis Parts, 400/480V, Delta M4/M6/M9	7-12
Chassis Parts, M14, 14:1 Pump	7-16
Chassis Parts, M14, 21:1 Pump	7-18
Chassis Parts, M14, 10:1 Pump	7-20
Transformer Base Assembly (400/480V Delta)	7-24
Frame Assembly	7-28
Frame Parts	7-28
Bulkhead Parts	7-32
Solenoid Parts, 14:1 Pumps	7-34
Solenoid Parts, 10:1 and 21:1 Pumps	7-35
Lid Assembly	7-36
Tank/Manifold Assembly	7-38
Tank/Manifold Parts, 200–240V or 400/230 Y	7-38
Tank/Manifold Parts, 400/480V Delta	7-40
Manifold Parts	7-42
Manifold Filter Parts	7-43
Pump Assembly	7-44
14:1 Pump UpTime Pack Parts	7-44
14:1 Pump Parts	7-46
21:1 Pump and Actuator Parts	7-48
21:1 Pump Parts	7-50
21:1 Pump Actuator Parts	7-52
10:1 Pump and Solenoid Parts	7-54
Left Cover Assembly	7-56
Left Cover Parts, Two Hose/Gun Melters	7-56
Left Cover Parts, Four/Six Hose/Gun Melters	7-58
Left Cover Parts, Two Hose/Gun MESA 4	7-59
Right Cover Assembly	7-60
Right Cover Parts, Two/Four Hose/Gun MESA 4	7-60
Right Cover Assembly, M14, 6 H/G	7-61

Tank Cover Assembly	7-62
Front Panel Assembly	7-64
Melter Wiring	7-66
Recommended Spare Parts	7-66
Electrical Components (200–240V or 400/230 Y)	7-66
Electrical Components (400/480V Delta)	7-66
Pumps	7-67
Consumables and Wear Items	7-67
Supplies and Tools	7-68
Technical Data	8-1
General Specifications	8-1
Mesa 4 Melter	8-1
Mesa 6 Melter	8-3
Mesa 9 Melter	8-4
Mesa 14 Melter	8-5
Electrical Specifications	8-6
Heater Specifications	8-6
Melter Dimensions	8-7
Wiring Diagram	8-8
Calculating Melter Power Requirements	A-1
Calculating Hose/Gun Capacity	A-2
Power Data Tables	A-5
Operating Parameters	B-1
Standard	B-2
Temperature Control	B-5
Seven-day Clock	B-8
Example 1	B-9
Example 2	B-9
Example 3	B-9
400/480 Volt Mesa Adhesive Melters	C-1
Introduction	C-1
Safety	C-1
Intended Use	C-1
Unintended Use	C-2
Transformer Sizing	C-2
Transformer Base Function	C-3
Installation	C-4
Clearances	C-4
400/480 Volt Melter Weights	C-5
Installation Kit Components	C-6
Prepare the Transformer Base for Installation	C-7
Connect the Electrical Service to the Transformer Base	C-8
Attach the Support Leg (Mesa 6 and 9 only)	C-10
Mount the Transformer Base on the Parent Machine	C-11
Mount the Melter on the Transformer	C-12
Connect the Transformer to the Melter	C-13
Install the Configuration Jumper (480 VAC melter only)	C-14
Operation	C-14
Troubleshooting	C-15
400/480 Volt Mesa Cabling Diagram	C-16
400/480 Volt Mesa Wiring Diagrams	C-17

Section 1

Safety

Read this section before using the equipment. This section contains recommendations and practices applicable to the safe installation, operation, and maintenance (hereafter referred to as “use”) of the product described in this document (hereafter referred to as “equipment”). Additional safety information, in the form of task-specific safety alert messages, appears as appropriate throughout this document.



WARNING: Failure to follow the safety messages, recommendations, and hazard avoidance procedures provided in this document can result in personal injury, including death, or damage to equipment or property.

Safety Alert Symbols

The following safety alert symbol and signal words are used throughout this document to alert the reader to personal safety hazards or to identify conditions that may result in damage to equipment or property. Comply with all safety information that follows the signal word.



WARNING: Indicates a potentially hazardous situation that, if not avoided, can result in serious personal injury, including death.



CAUTION: Indicates a potentially hazardous situation that, if not avoided, can result in minor or moderate personal injury.

CAUTION: (Used without the safety alert symbol) Indicates a potentially hazardous situation that, if not avoided, can result in damage to equipment or property.

Responsibilities of the Equipment Owner

Equipment owners are responsible for managing safety information, ensuring that all instructions and regulatory requirements for use of the equipment are met, and for qualifying all potential users.

Safety Information

- Research and evaluate safety information from all applicable sources, including the owner-specific safety policy, best industry practices, governing regulations, material manufacturer's product information, and this document.
- Make safety information available to equipment users in accordance with governing regulations. Contact the authority having jurisdiction for information.
- Maintain safety information, including the safety labels affixed to the equipment, in readable condition.

Instructions, Requirements, and Standards

- Ensure that the equipment is used in accordance with the information provided in this document, governing codes and regulations, and best industry practices.
- If applicable, receive approval from your facility's engineering or safety department, or other similar function within your organization, before installing or operating the equipment for the first time.
- Provide appropriate emergency and first aid equipment.
- Conduct safety inspections to ensure required practices are being followed.
- Re-evaluate safety practices and procedures whenever changes are made to the process or equipment.

User Qualifications

Equipment owners are responsible for ensuring that users:

- receive safety training appropriate to their job function as directed by governing regulations and best industry practices
- are familiar with the equipment owner's safety and accident prevention policies and procedures
- receive, equipment- and task-specific training from another qualified individual

NOTE: Nordson can provide equipment-specific installation, operation, and maintenance training. Contact your Nordson representative for information

- possess industry- and trade-specific skills and a level of experience appropriate to their job function
- are physically capable of performing their job function and are not under the influence of any substance that degrades their mental capacity or physical capabilities

Applicable Industry Safety Practices

The following safety practices apply to the use of the equipment in the manner described in this document. The information provided here is not meant to include all possible safety practices, but represents the best safety practices for equipment of similar hazard potential used in similar industries.

Intended Use of the Equipment

- Use the equipment only for the purposes described and within the limits specified in this document.
- Do not modify the equipment.
- Do not use incompatible materials or unapproved auxiliary devices. Contact your Nordson representative if you have any questions on material compatibility or the use of non-standard auxiliary devices.

Instructions and Safety Messages

- Read and follow the instructions provided in this document and other referenced documents.
- Familiarize yourself with the location and meaning of the safety warning labels and tags affixed to the equipment. Refer to *Safety Labels and Tags* at the end of this section.
- If you are unsure of how to use the equipment, contact your Nordson representative for assistance.

Installation Practices

- Install the equipment in accordance with the instructions provided in this document and in the documentation provided with auxiliary devices.
- Ensure that the equipment is rated for the environment in which it will be used and that the processing characteristics of the material will not create a hazardous environment. Refer to the Material Safety Data Sheet (MSDS) for the material.
- If the required installation configuration does not match the installation instructions, contact your Nordson representative for assistance.
- Position the equipment for safe operation. Observe the requirements for clearance between the equipment and other objects.
- Install lockable power disconnects to isolate the equipment and all independently powered auxiliary devices from their power sources.
- Properly ground all equipment. Contact your local building code enforcement agency for specific requirements.
- Ensure that fuses of the correct type and rating are installed in fused equipment.
- Contact the authority having jurisdiction to determine the requirement for installation permits or inspections.

Operating Practices

- Familiarize yourself with the location and operation of all safety devices and indicators.
- Confirm that the equipment, including all safety devices (guards, interlocks, etc.), is in good working order and that the required environmental conditions exist.
- Use the personal protective equipment (PPE) specified for each task. Refer to *Equipment Safety Information* or the material manufacturer's instructions and MSDS for PPE requirements.
- Do not use equipment that is malfunctioning or shows signs of a potential malfunction.

Maintenance and Repair Practices

- Perform scheduled maintenance activities at the intervals described in this document.
- Relieve system hydraulic and pneumatic pressure before servicing the equipment.
- De-energize the equipment and all auxiliary devices before servicing the equipment.
- Use only new factory-authorized refurbished or replacement parts.
- Read and comply with the manufacturer's instructions and the MSDS supplied with equipment cleaning compounds.

NOTE: MSDSs for cleaning compounds that are sold by Nordson are available at www.nordson.com or by calling your Nordson representative.

- Confirm the correct operation of all safety devices before placing the equipment back into operation.
- Dispose of waste cleaning compounds and residual process materials according to governing regulations. Refer to the applicable MSDS or contact the authority having jurisdiction for information.
- Keep equipment safety warning labels clean. Replace worn or damaged labels.

Equipment Safety Information

This equipment safety information is applicable to the following types of Nordson equipment:

- hot melt and cold adhesive application equipment and all related accessories
- pattern controllers, timers, detection and verification systems, and all other optional process control devices

Equipment Shutdown

To safely complete many of the procedures described in this document, the equipment must first be shut down. The level of shut down required varies by the type of equipment in use and the procedure being completed. If required, shut down instructions are specified at the start of the procedure. The levels of shut down are:

Relieving System Hydraulic Pressure

Completely relieve system hydraulic pressure before breaking any hydraulic connection or seal. Refer to the melter-specific product manual for instructions on relieving system hydraulic pressure.

De-energizing the System

Isolate the system (melter, hoses, guns, and optional devices) from all power sources before accessing any unprotected high-voltage wiring or connection point.

1. Turn off the equipment and all auxiliary devices connected to the equipment (system).
2. To prevent the equipment from being accidentally energized, lock and tag the disconnect switch(es) or circuit breaker(s) that provide input electrical power to the equipment and optional devices.

NOTE: Government regulations and industry standards dictate specific requirements for the isolation of hazardous energy sources. Refer to the appropriate regulation or standard.

Disabling the Guns

All electrical or mechanical devices that provide an activation signal to the guns, gun solenoid valve(s), or the melter pump must be disabled before work can be performed on or around a gun that is connected to a pressurized system.

1. Turn off or disconnect the gun triggering device (pattern controller, timer, PLC, etc.).
2. Disconnect the input signal wiring to the gun solenoid valve(s).
3. Reduce the air pressure to the gun solenoid valve(s) to zero; then relieve the residual air pressure between the regulator and the gun.

General Safety Warnings and Cautions

Table 1-1 contains the general safety warnings and cautions that apply to Nordson hot melt and cold adhesive equipment. Review the table and carefully read all of the warnings or cautions that apply to the type of equipment described in this manual.





Equipment types are designated in Table 1-1 as follows:

HM = Hot melt (melters, hoses, guns, etc.)

PC = Process control





CA = Cold adhesive (dispensing pumps, pressurized container, and guns)

Table 1-1 General Safety Warnings and Cautions

Equipment Type	Warning or Caution
HM	 <p>WARNING: Hazardous vapors! Before processing any polyurethane reactive (PUR) hot melt or solvent-based material through a compatible Nordson melter, read and comply with the material's MSDS. Ensure that the material's processing temperature and flashpoints will not be exceeded and that all requirements for safe handling, ventilation, first aid, and personal protective equipment are met. Failure to comply with MSDS requirements can cause personal injury, including death.</p>
HM	 <p>WARNING: Reactive material! Never clean any aluminum component or flush Nordson equipment with halogenated hydrocarbon fluids. Nordson melters and guns contain aluminum components that may react violently with halogenated hydrocarbons. The use of halogenated hydrocarbon compounds in Nordson equipment can cause personal injury, including death.</p>
HM, CA	 <p>WARNING: System pressurized! Relieve system hydraulic pressure before breaking any hydraulic connection or seal. Failure to relieve the system hydraulic pressure can result in the uncontrolled release of hot melt or cold adhesive, causing personal injury.</p>
HM	 <p>WARNING: Molten material! Wear eye or face protection, clothing that protects exposed skin, and heat-protective gloves when servicing equipment that contains molten hot melt. Even when solidified, hot melt can still cause burns. Failure to wear appropriate personal protective equipment can result in personal injury.</p>
<i>Continued...</i>	

General Safety Warnings and Cautions *(contd)*

Table 1-1 General Safety Warnings and Cautions *(contd)*

Equipment Type	Warning or Caution
HM, PC	 <p>WARNING: Equipment starts automatically! Remote triggering devices are used to control automatic hot melt guns. Before working on or near an operating gun, disable the gun's triggering device and remove the air supply to the gun's solenoid valve(s). Failure to disable the gun's triggering device and remove the supply of air to the solenoid valve(s) can result in personal injury.</p>
HM, CA, PC	 <p>WARNING: Risk of electrocution! Even when switched off and electrically isolated at the disconnect switch or circuit breaker, the equipment may still be connected to energized auxiliary devices. De-energize and electrically isolate all auxiliary devices before servicing the equipment. Failure to properly isolate electrical power to auxiliary equipment before servicing the equipment can result in personal injury, including death.</p>
HM, CA, PC	 <p>WARNING: Risk of fire or explosion! Nordson adhesive equipment is not rated for use in explosive environments and should not be used with solvent-based adhesives that can create an explosive atmosphere when processed. Refer to the MSDS for the adhesive to determine its processing characteristics and limitations. The use of incompatible solvent-based adhesives or the improper processing of solvent-based adhesives can result in personal injury, including death.</p>
HM, CA, PC	 <p>WARNING: Allow only personnel with appropriate training and experience to operate or service the equipment. The use of untrained or inexperienced personnel to operate or service the equipment can result in injury, including death, to themselves and others and can damage the equipment.</p>
<i>Continued...</i>	

Equipment Type	Warning or Caution
HM	 <p>CAUTION: Hot surfaces! Avoid contact with the hot metal surfaces of guns, hoses, and certain components of the melter. If contact can not be avoided, wear heat-protective gloves and clothing when working around heated equipment. Failure to avoid contact with hot metal surfaces can result in personal injury.</p>
HM	<p>CAUTION: Some Nordson melters are specifically designed to process polyurethane reactive (PUR) hot melt. Attempting to process PUR in equipment not specifically designed for this purpose can damage the equipment and cause premature reaction of the hot melt. If you are unsure of the equipment's ability to process PUR, contact your Nordson representative for assistance.</p>
HM, CA	<p>CAUTION: Before using any cleaning or flushing compound on or in the equipment, read and comply with the manufacturer's instructions and the MSDS supplied with the compound. Some cleaning compounds can react unpredictably with hot melt or cold adhesive, resulting in damage to the equipment.</p>
HM	<p>CAUTION: Nordson hot melt equipment is factory tested with Nordson Type R fluid that contains polyester adipate plasticizer. Certain hot melt materials can react with Type R fluid and form a solid gum that can clog the equipment. Before using the equipment, confirm that the hot melt is compatible with Type R fluid.</p>

Other Safety Precautions

- Do not use an open flame to heat hot melt system components.
- Check high pressure hoses daily for signs of excessive wear, damage, or leaks.
- Never point a dispensing handgun at yourself or others.
- Suspend dispensing handguns by their proper suspension point.

First Aid

If molten hot melt comes in contact with your skin:

1. Do NOT attempt to remove the molten hot melt from your skin.
2. Immediately soak the affected area in clean, cold water until the hot melt has cooled.
3. Do NOT attempt to remove the solidified hot melt from your skin.
4. In case of severe burns, treat for shock.
5. Seek expert medical attention immediately. Give the MSDS for the hot melt to the medical personnel providing treatment.

Safety Labels

Figure 1-1 illustrates the location of the product safety labels affixed to the equipment. Table 1-2 provides an illustration of the hazard identification symbols that appear on each safety label, the meaning of the symbol, or the exact wording of any safety message.

The installation kit provided with the melter may contain label overlays that are printed in a variety of languages. If required by governing safety regulations, apply the appropriate overlay to the text portion of the labels shown in Figure 1-1.

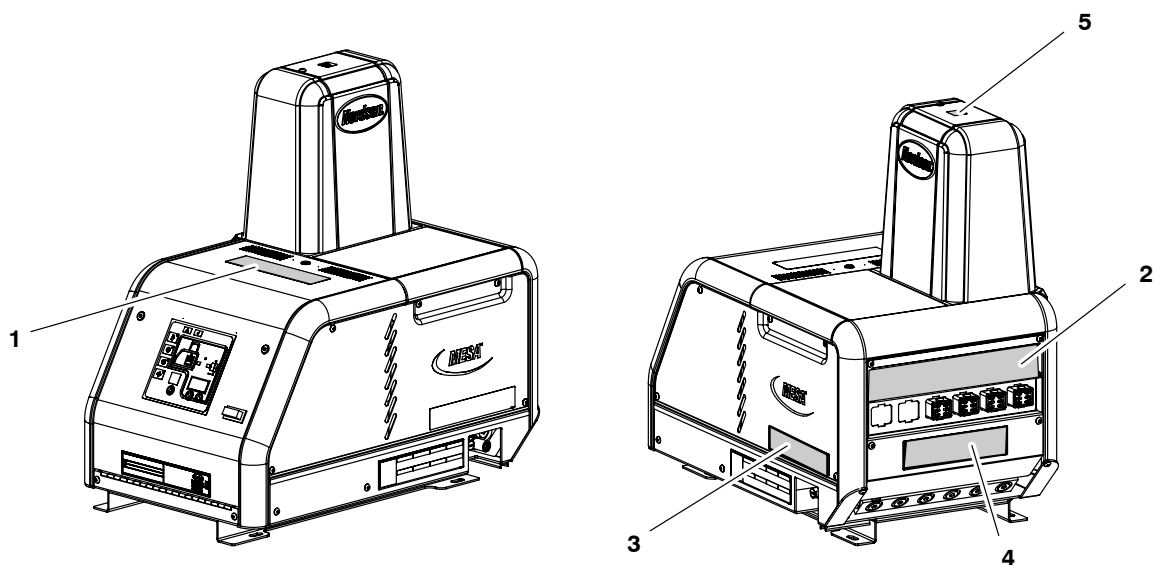



Figure 1-1 Safety labels

Table 1-2 Safety Labels

Item	Description
1	WARNING: Hazardous voltage. Disconnect all power supply connections before servicing.
2	WARNING: Burn hazard. Hot adhesive. Release pressure before servicing.
3	CAUTION Hot Surface. Do not touch.
4	WARNING Burn Hazard. Hot adhesive. Release pressure before servicing.
5	Hot surface
NS	 Tag, hazardous voltage [located inside the electrical cabinet on the main board]
NS: Not Shown	

This page intentionally left blank.

Section 2

Introduction

This manual describes the installation and use of the Mesa M4, M6, M9, and M14 adhesive melters. When necessary, the reader is referred to the documentation supplied with other Nordson products or products supplied by third parties.

With the exception of tank capacity, hose/gun capacity, and exterior appearance, all Mesa melters are functionally identical. To simplify the presentation of information in this manual, depictions of the model M4 are used generically throughout this manual to represent all Mesa melters.

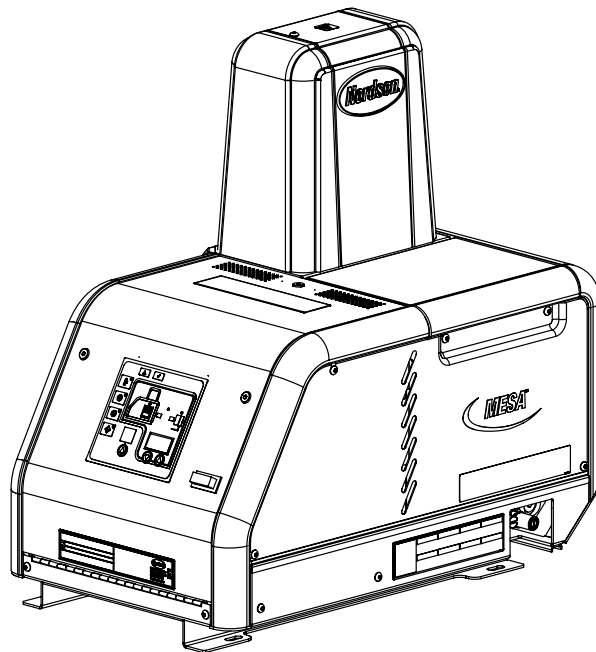

Product Description

See Figure 2-1. Nordson Mesa adhesive melters are used in conjunction with Nordson hot melt hoses and guns to create a hot melt application system.

The melter liquifies solid-form hot melt and maintains the hot melt at the desired temperature. When the guns are activated, the melter pumps the liquified hot melt through the hoses and out the gun nozzles, where it is commonly applied to the surface of a product.

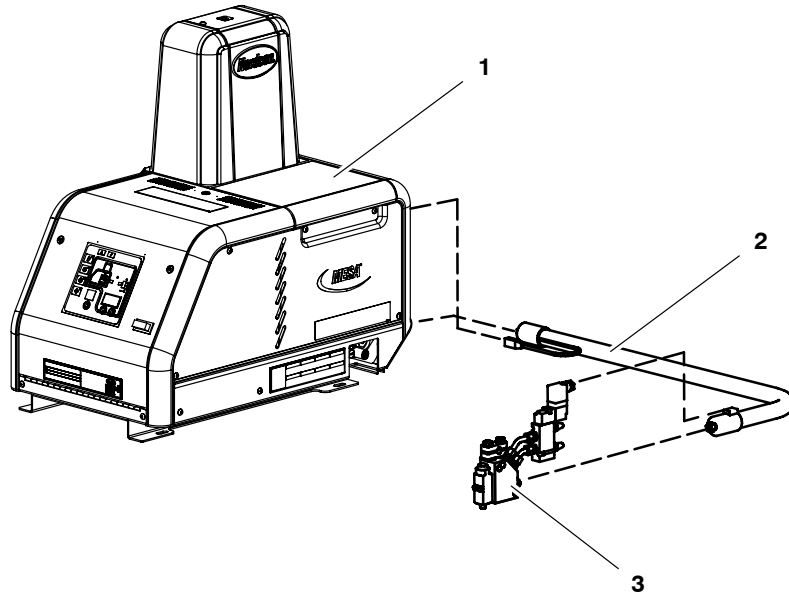

Figure 2-1 System components

- 1. Mesa melter
- 2. Hot melt hose

- 3. Hot melt gun

Intended Use

Mesa melters are specifically designed to:

- Melt and pump solid-form hot melt materials that are engineered to be liquified and extruded at temperatures below 230 °C (450 °F).
- Be used with compatible hot melt hoses and guns that are manufactured by Nordson Corporation
- Be used in non-explosive environments

Limitations of Use

Use Mesa melters only for the purpose for which they are designed. Mesa melters should not be used:

- to melt or pump polyurethane reactive hot melt materials or any other material that creates a health or safety hazard when heated
- in environments that will require the melter to be cleaned using a water wash or spray

Modes of Operation

Mesa melters operate in the following modes:

Automatic scan—The melter automatically checks and displays the current temperature of the tank, hoses, and guns to confirm that they are within their pre-defined temperature range. By default, the melter is always in the automatic scan mode unless it is placed into another operating mode.

Standby—The temperatures of the tank, hoses, and guns are reduced down from their operating temperature (hereafter referred to as setpoint temperature) by a pre-set number of degrees.

Setup—The setup mode is used to configure melter control options and features and to review stored operating data. To prevent unauthorized changes to the melter's configuration, the melter can be password-protected.

Fault—The melter alerts the operator when an abnormal event occurs.

Melter Identification

You will need the model and part number of your melter when requesting service or ordering spare parts and optional equipment. The model and part number are indicated on the equipment identification plate that is located on the side of the melter.

Key Components

Figure 2-2 provides the name and the location of key melter components.

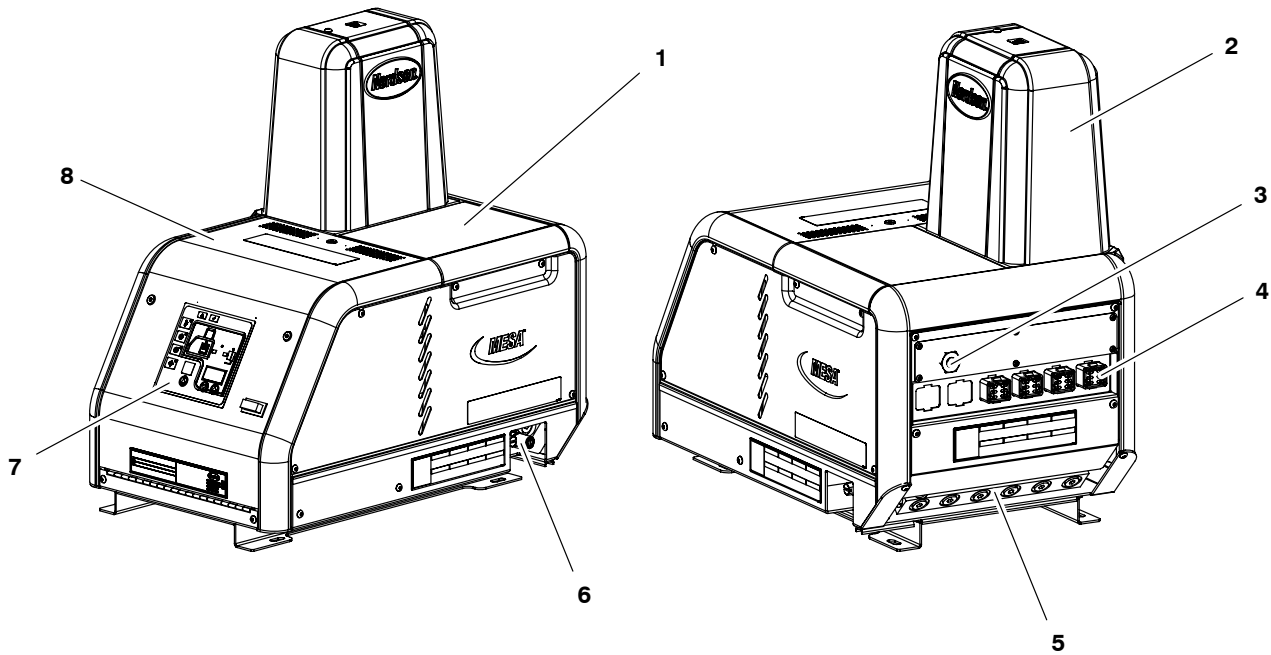

Figure 2-2 Key melter components

- | | | |
|--------------------|--------------------------------|------------------------------|
| 1. Tank lid | 4. Hose electrical connections | 7. Control panel |
| 2. Pump (inside) | 5. Manifold | 8. Electrical enclosure door |
| 3. Air supply port | 6. Drain valve and filter | |

Tank

See Figure 2-3.

The tank melts the adhesive and holds it until it is pumped to the dispensing guns. With its aluminum construction, cast-in heaters, and integral melting fins, the tank is designed for efficient heat transfer. A strainer in the tank prevents unmelted adhesive from blocking the pump inlet when you fill the tank. It also prevents pieces of cardboard and other small objects from entering the pump.

The standard tank is Teflon-coated for easy cleaning.

Refer to *General Specifications* in Section 8, *Technical Data*, for the tank storage capacity and other key information about the tank.

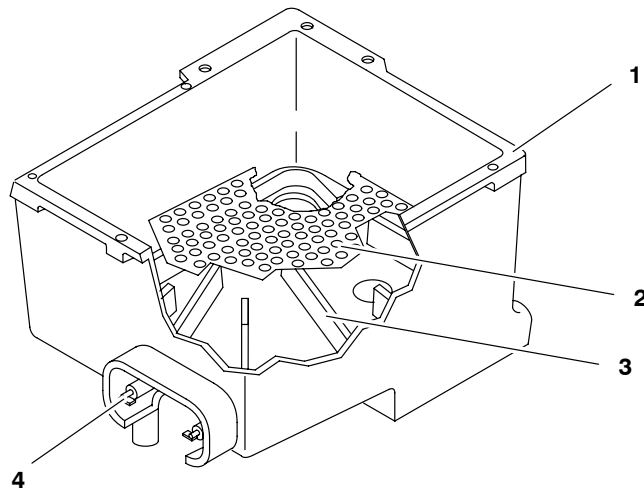

Figure 2-3 Key parts of the tank

- | | |
|-----------------|---------------------|
| 1. Tank casting | 3. Melting fins |
| 2. Strainer | 4. Heater connector |

Pump

See Figure 2-4.

The pump transfers melted adhesive from the tank to the dispensing guns. Your melter may have either a dual-acting or single-acting piston pump. A dual-acting piston pump delivers adhesive on both the upstroke and the downstroke. A single-acting piston pump delivers adhesive on the downstroke and draws in fresh adhesive on the upstroke.

Refer to *General Specifications* in Section 8, *Technical Data*, for the pump delivery rate and other key information about the pump.

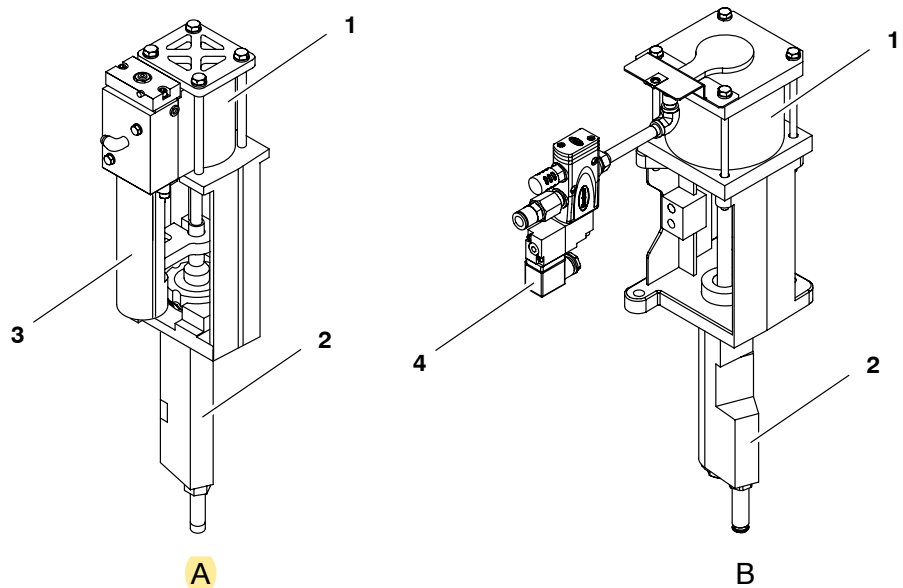

Figure 2-4 Key parts of the dual-acting (A) or single-acting (B) pump

- | | |
|----------------------|------------------------------|
| 1. Air motor | 3. Actuator |
| 2. Hydraulic section | 4. Triggering solenoid valve |

Manifold

See Figure 2-5.

The manifold directs the flow of adhesive from the pump to the filter and from the filter to the hoses and guns.

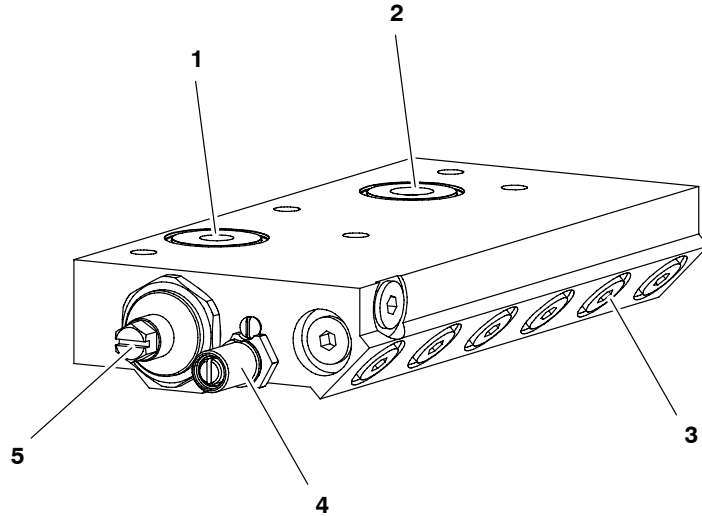

Figure 2-5 Key parts of the manifold

- | | |
|---|--------------------|
| 1. Adhesive outlet
(pressure relief valve not shown) | 4. Drain valve |
| 2. Adhesive inlet | 5. Manifold filter |
| 3. Hose ports | |

Hose Ports

The manifold block has a 45-degree face for either horizontal or vertical hose routing. A maximum of six hoses can be connected to the manifold.

Manifold Filter

The manifold filter traps any char or foreign material, keeping it from being pumped to the hoses and guns. The melter is shipped with a 0.15-mm (0.006-in.) filter screen. Other screen sizes are available.

Drain Valve

The drain valve allows you to drain the tank and manifold or to flush char and debris from the filter screen. Operators can perform the filter flushing procedure without removing the filter from the manifold.

Pressure Relief Valve

The pressure relief valve prevents system hydraulic pressure from exceeding 103.4 bar (10342 kPa, 1500 psi). At this pressure, the valve opens and returns adhesive to the tank.

Air Pressure Regulator

See Figure 2-6.

The air pressure regulator allows you to adjust the system air pressure, which controls the hydraulic pressure.

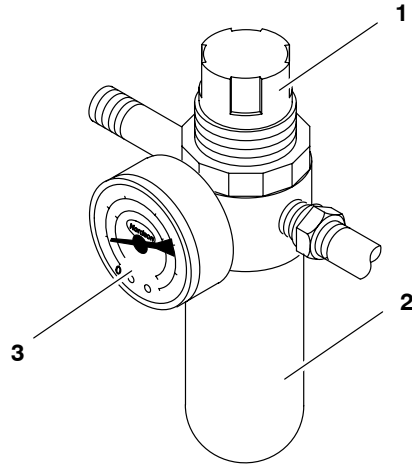

Figure 2-6 Key parts of the air pressure regulator

- | | |
|--------------|-----------------------|
| 1. Regulator | 3. Air pressure gauge |
| 2. Filter | |

Control Panel

See Figure 2-7.

The control panel provides the controls and indicators you need to program, operate, and monitor your hot melt system.

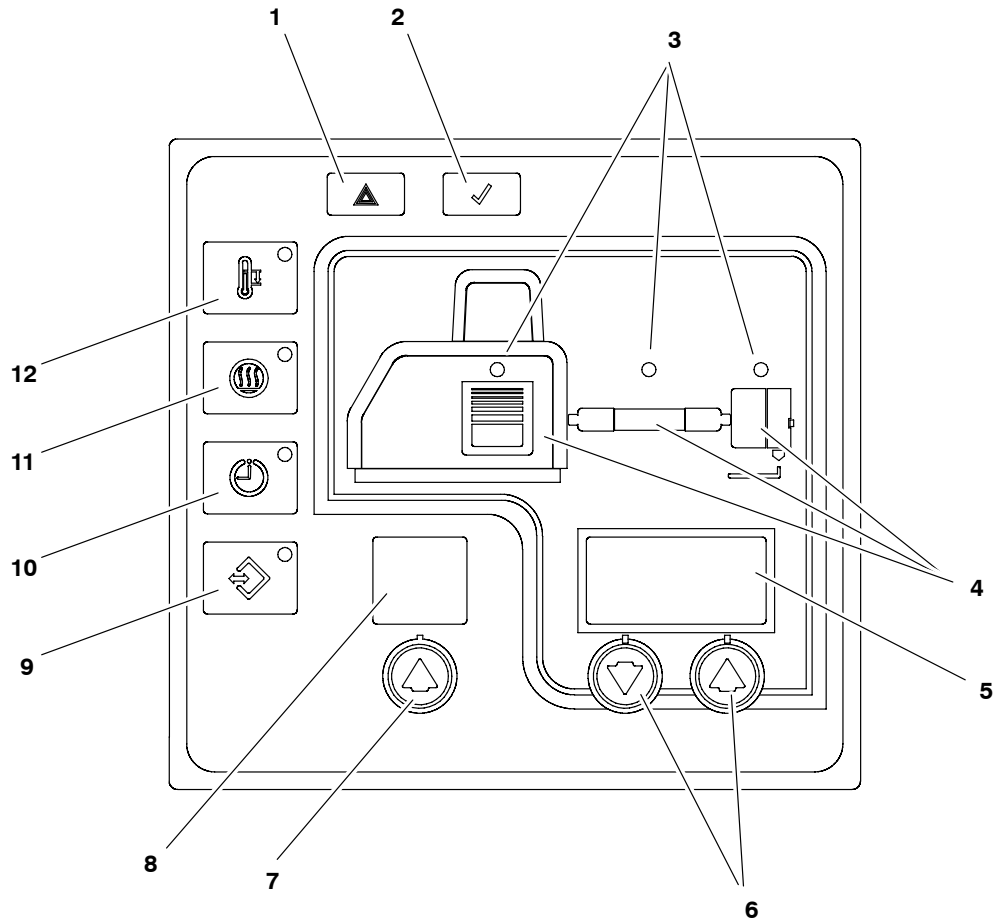

Figure 2-7 Control panel components

- | | | |
|--------------------------|-----------------------|-----------------|
| 1. Fault LED | 5. Right display | 9. Setup key |
| 2. Ready LED | 6. Right display keys | 10. Clock key |
| 3. Component status LEDs | 7. Left display key | 11. Heaters key |
| 4. Component keys | 8. Left display | 12. Standby key |

This page intentionally left blank.

Section 3

Installation



WARNING: Allow only personnel with appropriate training and experience to operate or service the equipment. The use of untrained or inexperienced personnel to operate or service the equipment can result in injury, including death, to themselves and others, and damage to the equipment.

Installing 400/480 Volt Melters

Refer to Appendix C, *400/480 Volt Mesa Adhesive Melters*, for information about installing 400/480 volt Mesa melters. After completing the procedures described in Appendix C, you will be referred back to this section to set up the melter.

Overview

Mesa melters are factory-configured for each order and require only the assembly and set up tasks described in this section.

The melter is shipped from the factory with an installation kit that contains components that must be assembled on the melter by the customer. Some additional materials must also be supplied by the customer to complete the installation.

If optional equipment was ordered with the melter, the documentation provided with the optional equipment for installation and operating instructions.

The illustrations accompanying the procedures in this section depict the M4 melter. Unless otherwise noted, the instructions also apply to the M6, M9, and M14 melters.

Additional Information



This section presents installation procedures in their most commonly used form. Procedural variations or special considerations are explained in the additional information table that follows most procedures. Where applicable, some table entries also contain cross-reference information. Additional information tables are indicated by the symbol shown to the left.

Installation Tasks

The installation sequence is as follows:

1. Verify that the required installation conditions and utilities exist.
2. Unpack and inspect the melter.
3. Mount the melter on the parent machine or support structure.
4. Connect the electrical service.
5. Connect hot melt hoses and guns.
6. Connect a compressed air supply.
7. (If present) Connect the 10:1 pump solenoid valve to a triggering device.
8. Set up the melter to work with the manufacturing process.
9. Install optional equipment.
10. (If used) Connect a gun driver, pattern controller, or timer.
11. Flush the melter.

Experience of Installation Personnel

The instructions provided in this section are intended to be used by personnel who have experience in the following subjects:

- Hot melt application processes
- Industrial power and control wiring
- Industrial mechanical installation practices
- Basic process control and instrumentation

This page intentionally left blank.

Installation Requirements

Before installing the melter, ensure that the desired installation location provides the required clearances, environmental conditions, and utilities.

Clearances

Figure 3-1 illustrates the *minimum* clearances that are required between the melter and surrounding objects. Table 3-1 describes each clearance.

NOTE: 400/480 volt melter clearances are provided in Appendix C, *400/480 Volt Mesa Adhesive Melters*.

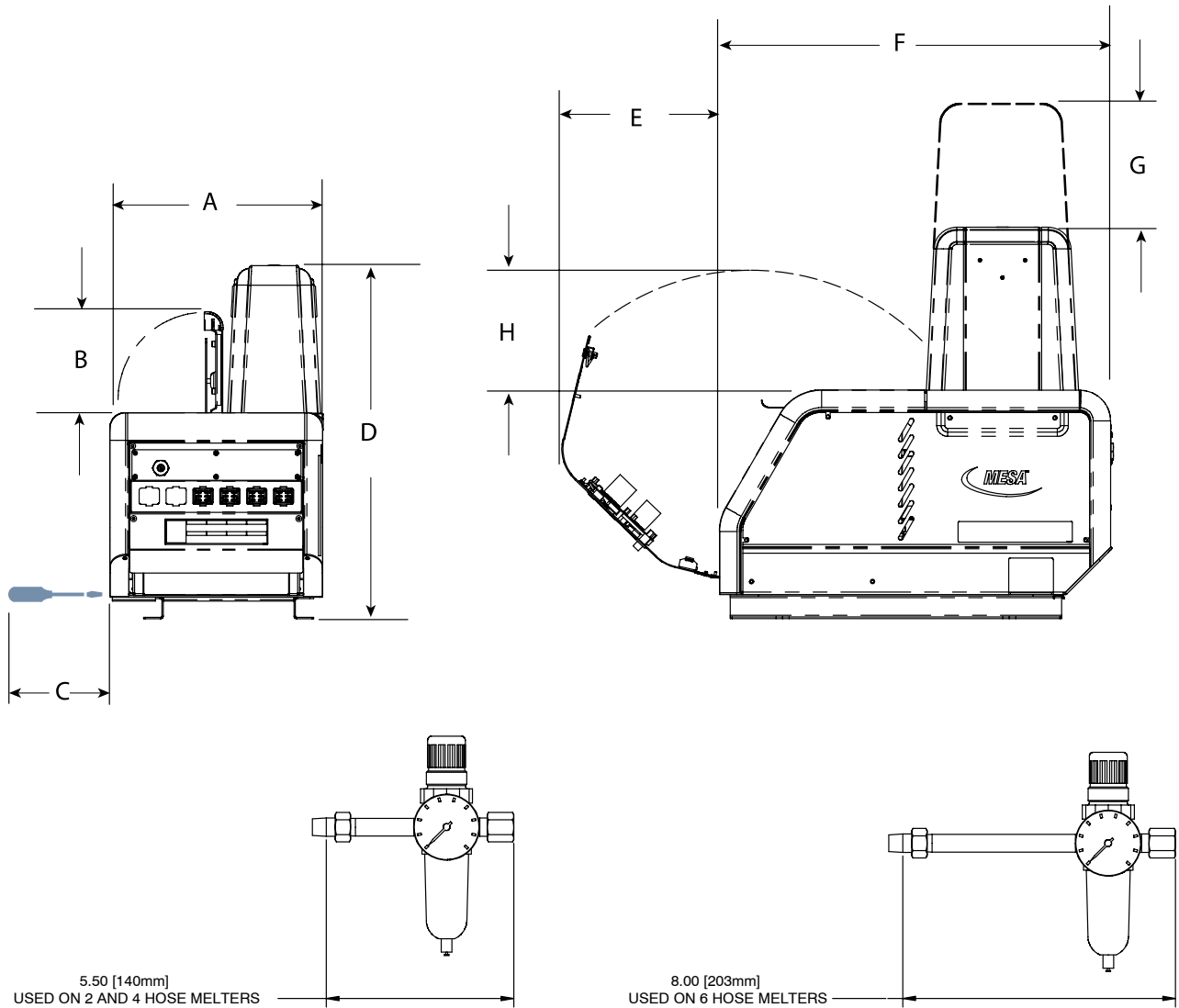

Figure 3-1 Minimum installation clearances

Table 3-1 Minimum Installation Clearances

Item	Required Clearance			
	M4	M6	M9	M14
A	343.70 mm (13.53 in.)	343.70 mm (13.53 in.)	343.70 mm (13.53 in.)	343.70 mm (13.53 in.)
B	162.93 mm (6.41 in.)	162.93 mm (6.41 in.)	162.93 mm (6.41 in.)	162.93 mm (6.41 in.)
C	203 mm (8.00 in.)	203 mm (8.00 in.)	203 mm (8.00 in.)	203 mm (8.00 in.)
D	569.84 mm (22.43 in.)	569.84 mm (22.43 in.)	569.84 mm (22.43 in.)	569.84 mm (22.43 in.)
E	229.48 mm (9.03 in.)	229.48 mm (9.03 in.)	229.48 mm (9.03 in.)	229.48 mm (9.03 in.)
F	573.82 mm (22.59 in.)	625 mm (24.61 in.)	690 mm (27.17 in.)	835 mm (32.88 in.)
G	239 mm (9.40 in.)	239 mm (9.40 in.)	239 mm (9.40 in.)	239 mm (9.40 in.)
H	126.56 mm (5.00 in.)	126.56 mm (5.00 in.)	126.56 mm (5.00 in.)	126.56 mm (5.00 in.)

Electrical Power

Before installing the melter, ensure that the melter will not be overloaded and that the plant's electrical service is rated to handle the power required by the melter and the hoses and guns that you plan to use.

Refer to Appendix A, *Calculating Melter Power Requirements*, for information about how to calculate the maximum allowable hose lengths and gun wattages that can be used in your manufacturing application.

NOTE: Refer to Appendix C, *400/480 Volt Mesa Adhesive Melters*, for 400/480 volt melter power requirements.



WARNING: Risk of electrocution! Install a lockable power disconnect switch between the electrical service and the melter. Failure to install or properly use the disconnect switch when servicing the melter can result in personal injury, including death.

Other Considerations

Carefully select the location for the melter and its associated guns and hoses. Make sure that the location meets the following requirements:

- There is enough room to open the tank lid, open the electrical enclosure, remove the filter assembly, remove the pump enclosure, and make electrical connections for the hoses. For recommended melter clearances, refer to *Clearances* in this section. For melter dimensions, refer to *Melter Dimensions* in Section 8, *Technical Data*.
- Maintenance personnel have room to service and repair the melter.
- The mounting surface can support the weight of the melter when the melter is filled with adhesive. Refer to *General Specifications* in Section 8, *Technical Data*.
- The mounting surface is level.

- The mounting surface is raised at least 152 mm (6 in.) for draining adhesive. See Figure 3-2.
- The drain valve projects over the edge of the mounting surface.
- The maximum distance between the melter and each gun is dictated by the power requirement of each hose. Refer to Appendix A, *Calculating Melter Power Requirements*, for information about how to determine the maximum allowable length.
- The operator must be able to safely reach the control panel and accurately monitor the control panel indicators.
- The operator must be able to safely observe the level of hot melt inside the tank.
- The melter must be installed away from areas with strong drafts or where sudden temperature changes occur.
- The melter must be installed where it will be in conformance with the ventilation requirements specified in the Material Safety Data Sheet for the hot melt being used.

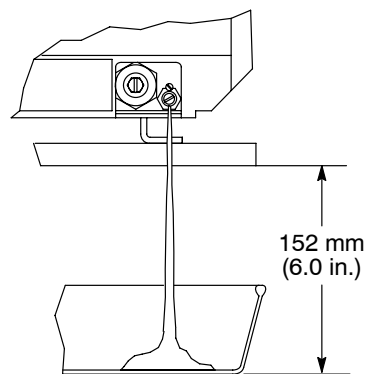

Figure 3-2 Required clearance for draining and filter flushing

Unpacking the Melter

Before starting the installation, remove the melter from the pallet, locate the installation kit, and inspect the melter for damaged and missing parts. Report any problems to your Nordson representative.

Contents of the Installation Kit

The installation kit provided with the melter contains the components shown in Figure 3-3.

NOTE: 400/480 volt melters and transformer bases are each shipped with an installation kit. Refer to Appendix C, *400/480 Volt Mesa Adhesive Melters*, for information about the contents of the installation kits.

The melter installation kit contains a package of safety label overlays that are printed in variety of languages. If required by local regulations, the appropriate language overlay should be applied over the English version of the same label. Refer to *Safety Labels and Tags* in Section 1, *Safety*, for the location of each safety label.

Customer-Supplied Materials

The following additional materials are also required to install the melter:

- Strain relief (at the disconnect switch box)
- Hardware to secure the melter to the mounting surface

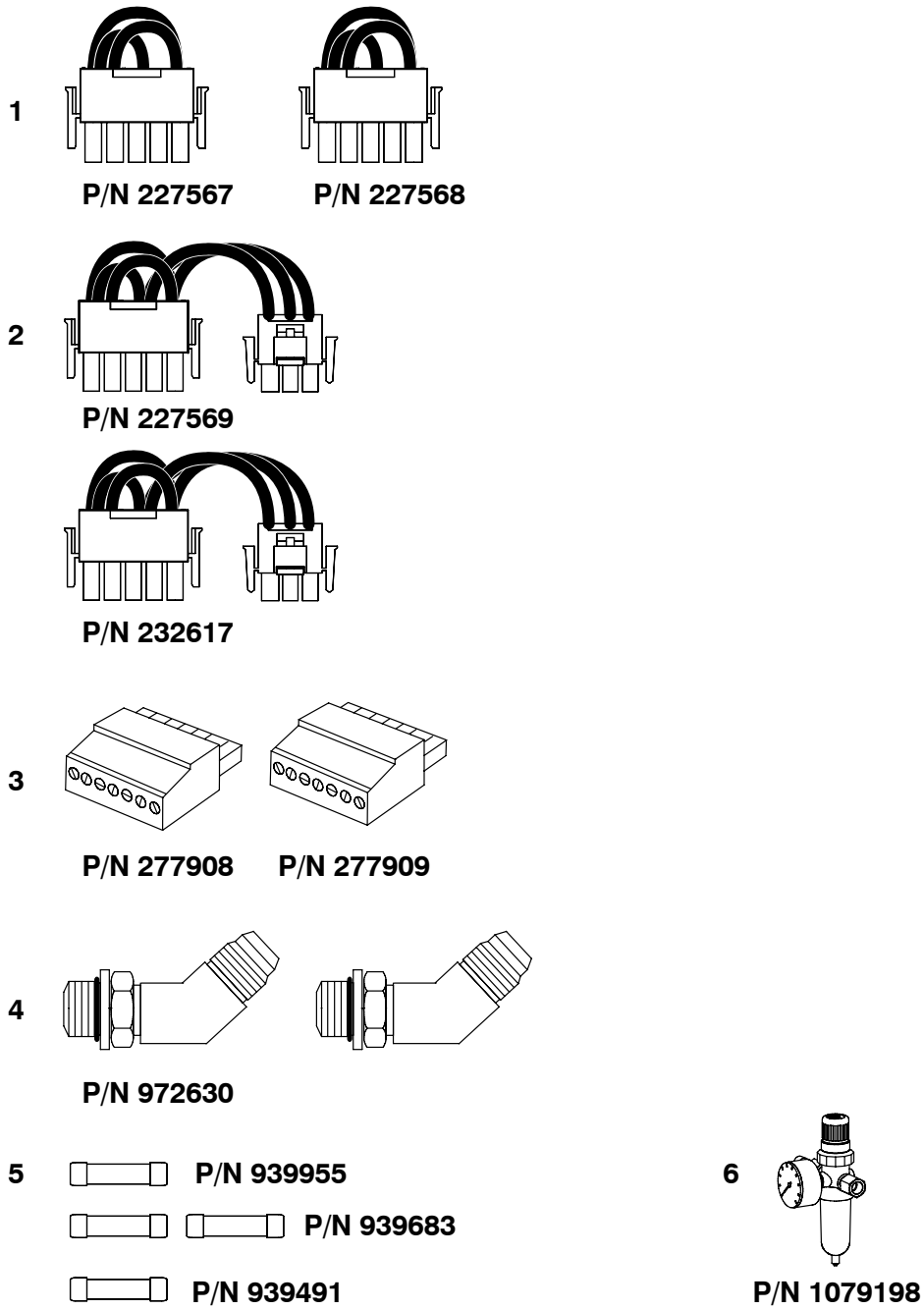

Figure 3-3 Installation kit components

- | | | |
|--------------------------------------|-------------------------------------|------------------|
| 1. Voltage plugs without neutral (2) | 3. Input and output connectors (2) | 5. Fuses (4) |
| 2. Voltage plugs with neutral (2) | 4. 45-degree hose fittings (2 or 4) | 6. Regulator (1) |

Mounting the Melter

Before mounting the melter, ensure that the parent machine or support structure is level with respect to the floor, provides an even mounting surface, is not subject to extreme vibration, and is capable of supporting the weight of the melter, a full tank of hot melt, and the hoses and guns.

Refer to Section 8, *Technical Data*, for the weight of the melter. Refer to the technical data provided by the hot melt manufacturer for information about the volumetric weight of the hot melt.

To mount the melter

See Figure 3-4.

Secure the melter mounting brackets to the mounting surface.

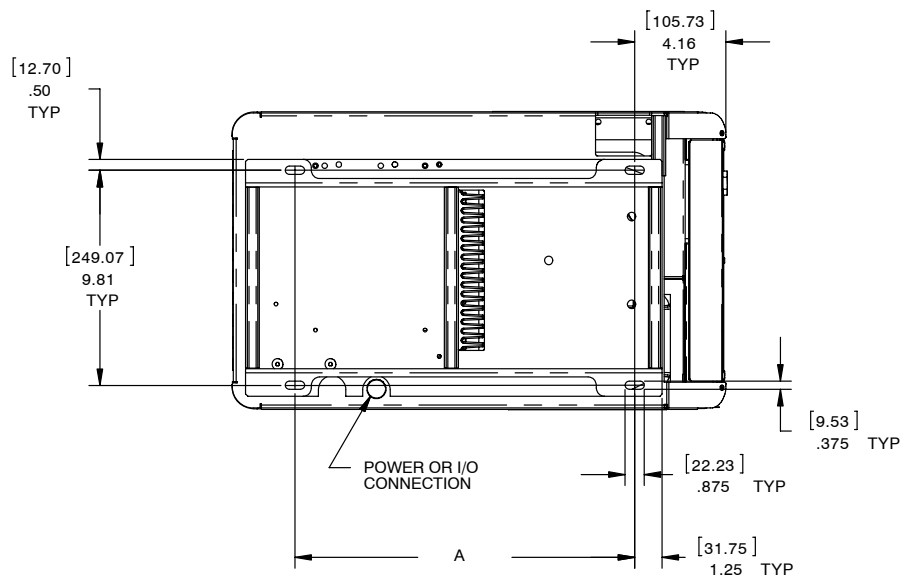

Figure 3-4 Bolt mounting pattern (refer to Table 3-2)

Table 3-2 Bolt Mounting Pattern Dimension A

Item	Dimension			
	M4	M6	M9	M14
A	394 mm (15.50 in.)	394 mm (15.50 in.)	445 mm (17.50 in.)	584 mm (23.0 in.)

Configuring the Electrical Service

NOTE: Refer to Appendix C, *400/480 Volt Mesa Adhesive Melters*, for information about configuring the electrical service for 400/480 volt melters.

Mesa melters are shipped from the factory without an attached power cable and without a designated service-type. To configure the melter to function in your facility, you must connect a power cable to the melter and designate the service-type by installing a Nordson-supplied voltage plug into the melter.

To connect a power cable to the melter



WARNING: Risk of electrocution! Install a lockable power disconnect switch between the electrical service and the melter. Failure to install or properly use the disconnect switch when servicing the melter can result in personal injury, including death.

1. Select a 10 mm² (8 AWG) power cable that meets applicable electrical codes and standards. The maximum amperages of Mesa melters operating at a specified voltage are shown in Table 3-3.

Table 3-3 Melter Power Requirements

Melter	Number of Hose/Guns	1-Phase Power Draw (Amps)	3-Phase Power Draw (Amps)	
			230 VAC With Neutral	240 VAC Without Neutral
M4	2	17	16	14–17
	4	25	16	18–22
	6	34	17	24–29
M6	2	18	17	15–18
	4	27	17	20–23
M9	4	30	21	22–27
M14	4	35	25	26–31
	6	--	25	32–38

Configuring the Electrical Service *(contd)*

2. Open the electrical enclosure door.
3. Route the power cable between the power disconnect switch and the melter and then through one of the PG-21 or 1-inch conduit penetration on the side or floor of the electrical compartment.

See Figure 3-5.

4. Connect each power cable lead to terminal block XT1. Table 3-4 lists the terminals that are used for each of the electrical service types that are compatible with the melter.
5. Connect the ground lead from the power cable to the ground lug that is located on the chassis. The ground lug is marked PE/G.

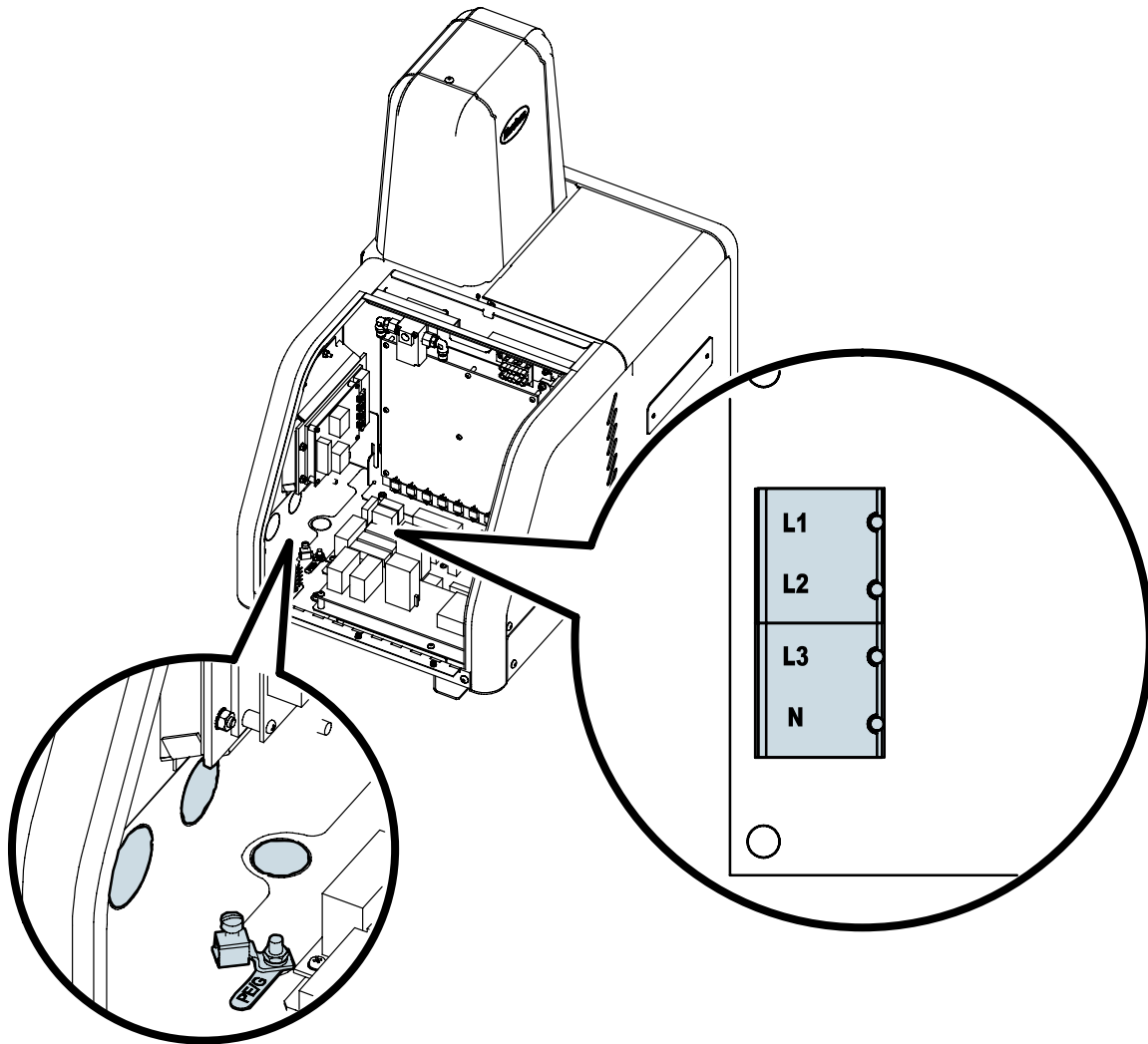

Figure 3-5 Connecting the power cable and ground lead

- 1. Knockouts
- 2. Ground lug (PE/G)
- 3. Terminal XT1

Configuring the Electrical Service *(contd)*

Table 3-4 Connecting the Electrical Service

Figure No.	If the Electrical Service Type is..		Use Electrical Connector Terminals..				Use Voltage Plug..
			L1	L2	L3	N	
1	400/230 VAC 3-phase (4-wire service, including a neutral) See Note.	3/N/PE AC 400/230V	●	●	●	●	227569 Red/yellow label White trace wiring
2	230 VAC 1-phase (2-wire service, including a neutral) See Note.	1/N/PE AC 200–240V	●			●	232617 Blue/yellow label Gray trace wiring
3	200 to 240 VAC 3-phase (3-wire service without a neutral)	3/PE AC 200–240V	●	●	●		227568 Red/green label Black trace wiring
4	200 to 240 VAC 1-phase (2-wire service without a neutral)	1/PE AC 200–240V	●	●			227567 Blue/green label Red trace wiring

NOTE: The 400/230 VAC 3-phase service (4-wire service including neutral) includes the 415/240 VAC 3-phase (4-wire service, including neutral) voltage. The 230 VAC 1-phase service (2-wire service, including a neutral) includes the 240 VAC 1-phase (2-wire service, including a neutral) voltage.

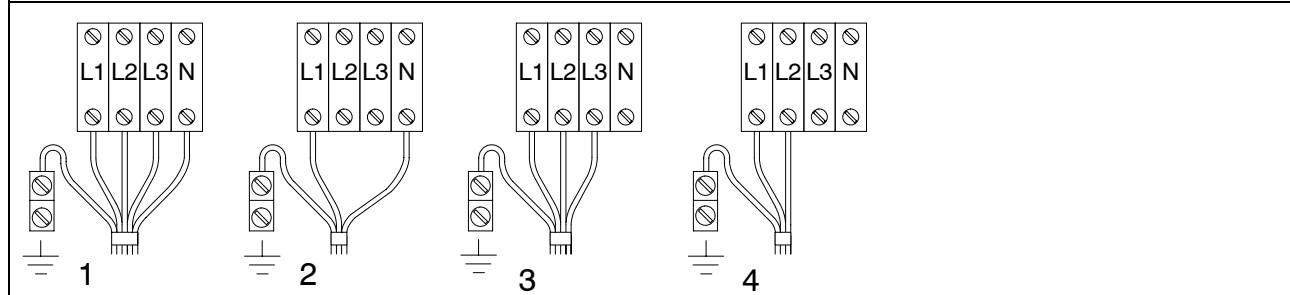

To connect a voltage plug to the melter

1. Refer to Table 3-4 to determine the part number of the voltage plug that matches the required electrical service. Each voltage plug is labeled with its part number and service type.

See Figure 3-6.

2. Insert the voltage plug into the receptacle on the power board. Ensure that the plug snaps into place. If the plug contains a neutral lead, connect the neutral lead to receptacle X2 and X3.
3. When the electrical service is completely installed and inspected in accordance with local electrical codes and standards, close the electrical enclosure door and switch the local power disconnect switch on.

If the electrical service was configured correctly, the melter control panel will display dashes.

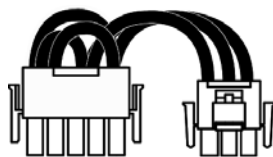

Typical voltage plugs (plugs with and without the neutral lead shown)

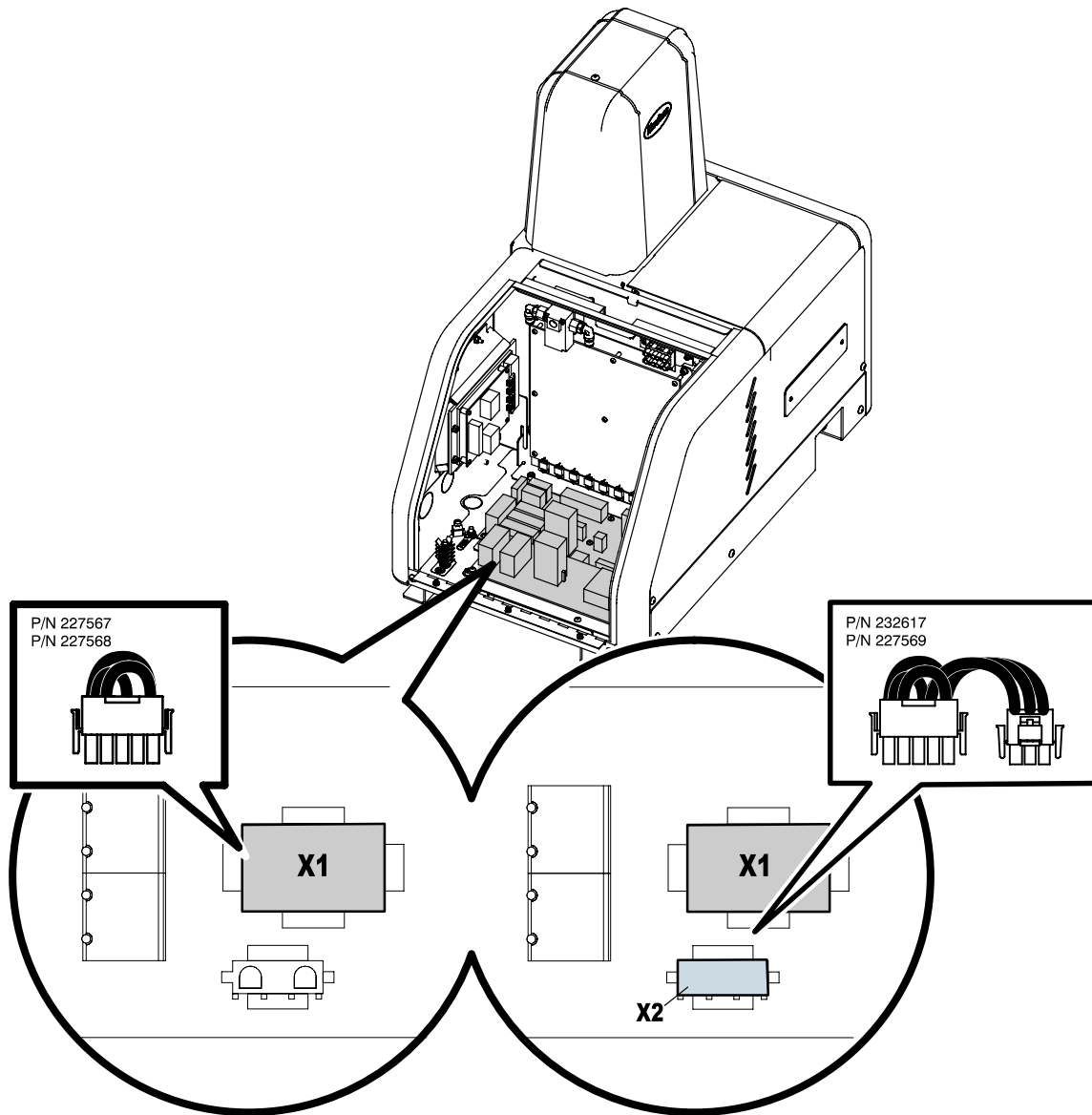

Figure 3-6 Connecting a voltage plug

Connecting Hoses and Guns

Mesa melters use standard Nordson hoses and guns and support the connection of up to six hose/gun pairs. Hose/gun capacity is dependent upon the melter's factory configuration.



WARNING: Risk of fire or equipment damage! Before connecting hoses and guns to the melter, confirm that the power required by the hoses and the guns does not exceed the maximum wattages specified in Appendix A, *Calculating Melter Power Requirements*.

To connect hoses

See Figure 3-7.

Observe the following guidelines:

- For information about choosing the correct Nordson hot melt hose for your manufacturing process, refer to the latest edition of Nordson's hot melt dispensing equipment *Replacement Parts Catalog* or contact your Nordson representative.
- Refer to the user's guide provided with each Nordson hose. The guide contains important information about routing and installing the hose.
- Save all of the plugs that were removed from the hose ports. A plug will need to be reinstalled into a hose port if a hose is later removed.

To connect hoses (contd)

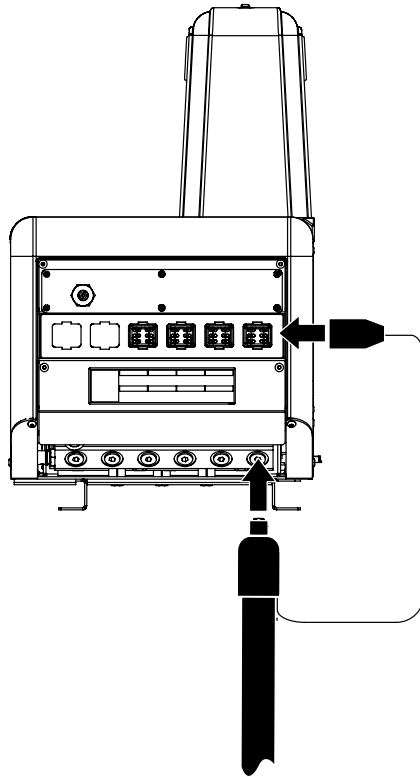

Figure 3-7 Hose hydraulic and electrical connection

Note: To prevent char buildup, connect the first hose to hose port 1, as shown. Connect subsequent hoses to hose ports 2, 3, and so on.

To connect guns

Observe the following guidelines:

- For information about choosing the most appropriate Nordson hot melt gun for your manufacturing process, refer to the latest edition of Nordson's hot melt dispensing equipment *Replacement Parts Catalog* or contact your Nordson representative. Refer to Appendix A, *Calculating Melter Power Requirements*, for information about how to calculate the power required by Nordson hot melt guns.
- Refer to the user's guide that is shipped with each gun for information about installing the gun and connecting a hose to the gun.

NOTE: Mesa melters are shipped with a 100-mesh (0.15 mm) hot melt filter installed in the manifold body. Filters with 50- and 150-mesh screens (0.11 mm and 0.07 mm respectively) are also available. Order the appropriate filter based on the smallest nozzle size used in your application.

Connecting a Compressed Air Supply

To connect an air supply

CAUTION: Rigidly support the plant air supply before connecting it to the air filter.

1. Connect a regulated plant air supply to the inlet of the air filter.

NOTE: The air filter inlet is threaded to receive a male G1/4 BSPP fitting.

2. Open the plant air supply to the melter.
3. Turn the pressure regulator adjustment clockwise to set the melter's operating air pressure (pressure supplied to the pump).

NOTE: To achieve the rated adhesive output of the unit, you must connect a plant air supply that is capable of providing the maximum air pressure specified on the unit. The maximum air pressure is either 4.8 bar (483 kPa, 70 psi) or 6.2 bar (620 kPa, 90 psi), depending upon the type of pump your unit has. To find the maximum air pressure for your unit, check the air pressure tag, which is located next to the inlet air port, above the hose connectors.

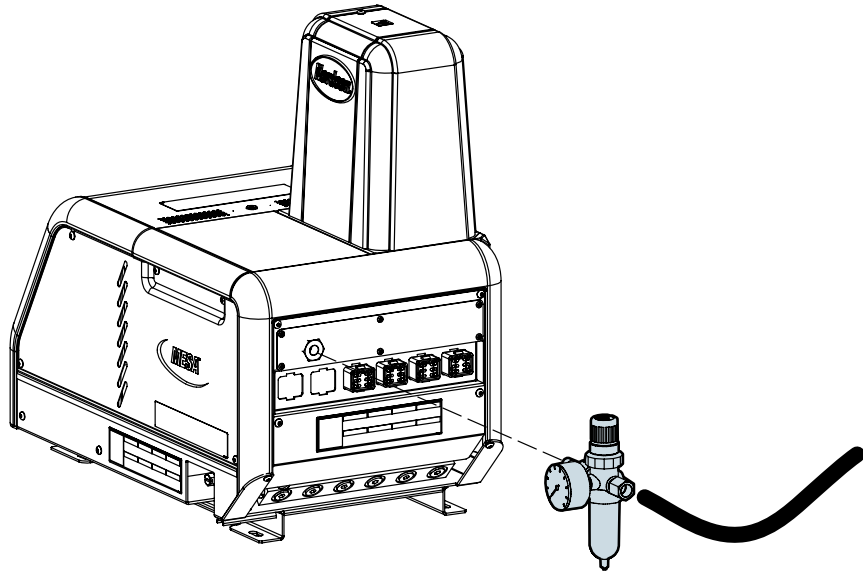

Figure 3-8 Connecting the air filter and the plant air supply line

This page intentionally left blank.

Connecting a Triggering Device for the Pump Solenoid Valve (10:1 Pump)

If your melter has a single-acting 10:1 pump and triggering solenoid valve as shown in Figure 3-9, follow this procedure to connect a 24 VDC triggering device to the center frame terminal block.

If your melter does not have a 10:1 pump, skip to the next procedure, *Setting Up the Melter*.

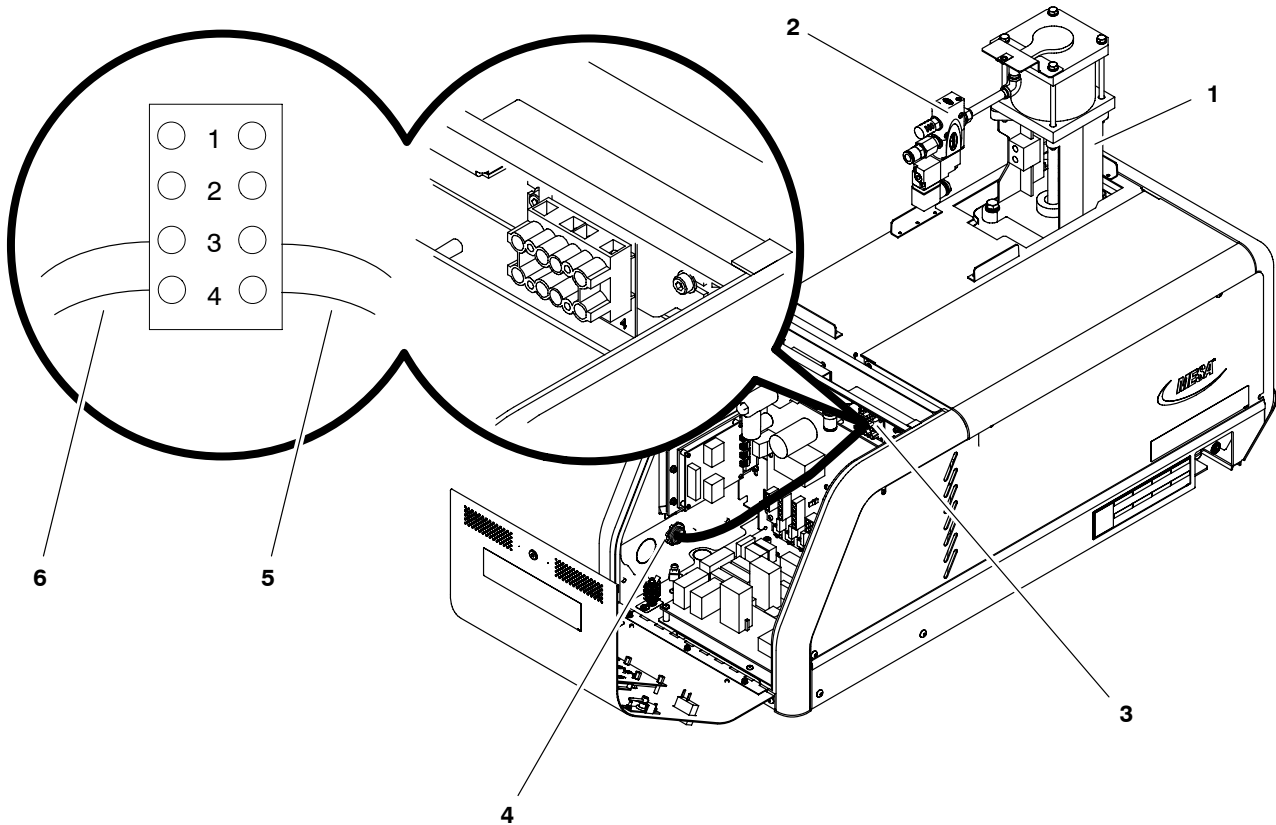

Figure 3-9 Connecting a triggering device for the pump solenoid valve (single-acting pump only)

- | | | |
|------------------------------|--------------------------------|--|
| 1. Single-acting 10:1 pump | 3. Center frame terminal block | 5. Wiring from customer's 24 VDC triggering device |
| 2. Triggering solenoid valve | 4. Strain relief | 6. Factory-installed wiring from triggering solenoid valve |



WARNING: Risk of equipment damage, personal injury or death. Install a strain relief to protect wires from being damaged by the edges of the knockout hole.

CAUTION: Circuit boards can be easily damaged. Avoid any contact with circuit boards when removing a knockout hole plug.

1. See Figure 3-9. Remove and discard the plug from a knockout hole on either the back side or the bottom of the unit (whichever is most convenient for your operation) and install a strain relief (4) in the hole. Refer to the following table for the appropriate size strain relief.

NOTE: Your unit may have several knockout holes. You should route your triggering device wires through a larger hole.

Size of Knockout	Size of Strain Relief to Install
23 mm ($1\frac{5}{16}$ in.)	PG-16 or $\frac{1}{2}$ -in. trade size
29.5 mm ($1\frac{5}{32}$ in.)	PG-21
35 mm ($1\frac{3}{8}$ in.)	1-in. trade size

CAUTION: Use 0.34–0.25 mm² (22–24 AWG) wire. Using a different wire size can cause internal stress-related damage to the unit.

2. Route the wires (5) from a 24 VDC triggering device through the strain relief and connect them to terminals 3 and 4 on the center frame terminal block (3).

Setting Up the Melter

After physically installing the melter, it must be set up to support your manufacturing process. Melter setup consists of enabling or making changes to factory-set operating parameters that affect the use and function of the melter. The operating temperature (setpoint) of the tank and each hose and gun is also established during melter setup.

The melter is shipped from the factory with the most commonly used operating parameters already set up. The factory setup can be modified at any time to suit your manufacturing process.

Quick Setup

Table 3-5 describes the most commonly used operating parameters and their factory settings. Review the table to determine if the factory settings for each parameter will support your manufacturing process. If the default values for each of these operating parameters are appropriate for your manufacturing process, then no melter setup is required.

Go directly to *Setpoint Temperature of the Tank, Hoses, and Guns* later in this section to complete the installation process.

If you need to make changes to the factory setup or if you want to learn about other operating parameters, go to the next part in this section, *Operating Parameters*.

Table 3-5 Common Operating Parameters

Parameter	Parameter Name	Purpose	Default Value
4	Ready Delay Time	A timer that delays the activation of the ready LED for a pre-defined time period after the tank, hoses, and guns are at the desired setpoint temperature. The ready delay timer will only activate if the temperature of the tank, at the time the melter is turned on, is below its assigned setpoint temperature by 27 °C (50 °F) or more.	0 minutes
11	Create Password	Sets a password that must be entered before any melter operating parameter or setpoint temperature can be changed.	5000
20	Temperature units	Sets the units of the temperature display to degrees Celsius (C) or to degrees Fahrenheit (F).	C
21	Over Temperature Delta	Sets the number of degrees that any heated component can exceed its assigned setpoint temperature before an over temperature fault occurs.	15 °C (25 °F)
22	Under Temperature Delta	Sets the number of degrees that any heated component can drop below its assigned setpoint temperature before an under temperature fault occurs.	25 °C (50 °F)
23	Standby Delta	Sets the number of degrees that the temperature of all heated components will be decreased when the melter is placed into the standby mode.	50 °C (100°F)
50 to 77	Seven-day Clock	A group of parameters that control the melter's clock. The clock is used to automatically turn the heaters on and off and to place the melter into the standby mode.	Disabled

Operating Parameters

The melter uses operating parameters to store noneditable and editable values. Noneditable values are those that provide information about the historical performance of the melter. Editable values are either a numeric setpoint or a control option setting. Control option settings affect the display of information or the function of the melter.

Operating parameters are stored in the melter's firmware in the form of a sequentially numbered list. The list is organized into the logical groups described in Table 3-6.

Table 3-6 Parameter Groups

Group	Parameter Numbers	Group Description
Standard	0 to 4, 10 to 11, and 14	Frequently used parameters
Temperature Control	20 to 25	Control heater function
Seven-day Clock	50 to 77	Configure the clock feature
NOTE: Refer to Table 3-7 for the exact parameters available on Mesa melters.		

In addition to the ability to read and edit parameter values, you can also review a log of the last ten changes that were made to editable parameters.

Selecting Operating Parameters

Table 3-7 provides a complete list of the operating parameters. Review the list to determine which operating parameters would best support your manufacturing process. Refer to Appendix B, *Operating Parameters*, for detailed information about each parameter. Appendix B contains a complete description of each parameter, including its affect on the melter, default value, and format.

NOTE: Parameters that are used to configure optional equipment or that are otherwise reserved in the firmware are excluded from Table 3-7.

Reading or Editing Operating Parameters

Regardless of whether a parameter's value is editable or not, the procedure for accessing each parameter in order to read or edit its current value is the same.

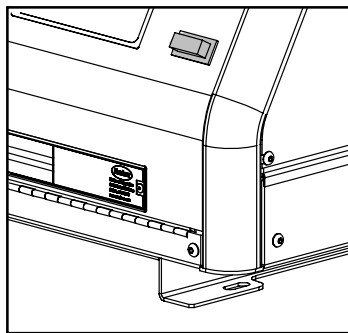
To read or edit a parameter

Control switch (on/off)

1. Switch the melter on.
The melter performs a start-up check.
2. Press the **Setup** key.
The left display flashes parameter 1.
3. Use the left-display scroll key to scroll to the desired parameter number. Refer to Table 3-7 for a complete list of parameters.
When you have finished entering the one- or two-digit parameter number, the right display indicates the parameter's current value.
4. Do *one* of the following:
 - If the value is noneditable, refer to *Monitoring the Melter* in Section 4, *Operation*.
 - If the value is editable go to step 5.
5. Press a right-display scroll key.
The right display flashes.
6. Use the right-display scroll keys to enter the desired numeric setpoint or control option into the right display. Refer to Appendix B, *Operating Parameters*, for information about the numeric value or control option choices for each parameter.
7. Press the left-display scroll key.
The melter checks that the new value or control option is acceptable.
 - If the numeric setpoint or control option is accepted, the left and right displays index to the next sequential parameter number and value.
 - If the numeric setpoint or control option is not accepted, the right display will indicate dashes (---) for three seconds and then it will change back to the original value.
8. Repeat step 5 through step 7 to read or change the next sequential parameter number or press the **Setup** key to exit the setup mode.

To read or edit a parameter (contd)

Table 3-7 Operating Parameters

Parameter	Name	Range of Values	Default Value
<i>Standard</i>			
0	Enter Password	0 to 9999	4000
1	Total Hours with Heaters On (noneditable)	9999	0
2	Fault Log (noneditable)	—	_-F0 (empty)
3	Change History Log (noneditable)	—	P-_ (empty)
4	Ready Delay Time	0 to 60 minutes	0 minutes
10	Enable or Disable Password	0 (disabled) or 1 (enabled)	0 (disabled)
11	Create Password	0 to 9999	5000
14	External Communications Lock-out	0 or 1	0 (disabled)
<i>Temperature Control</i>			
20	Temperature (degrees °C or °F)	C (degrees Celsius) or F (degrees Fahrenheit)	C (degrees Celsius)
21	Over Temperature Delta	15, 25, or 35 °C (25, 50, or 75 °F)	15 °C (25 °F)
22	Under Temperature Delta	15, 25, or 35 °C (25, 50, or 75 °F)	25 °C (50 °F)
23	Standby Delta	30, 50, or 80 °C (50, 100, or 150 °F)	50 °C (100 °F)
24	Automatic Standby Timeout	0, 120 or 150 minutes	0 (disabled)
25	Automatic Heaters Off Time	1, 60, or 120 minutes	1 (enabled)
<i>Seven-day Clock</i>			
50	Current Day	1 to 7 (1 = Monday)	—
51	Current Hour	0000 to 2359	—
55	Schedule 1 Heaters On	0000 to 2359	06:00
56	Schedule 1 Heaters Off	0000 to 2359	17:00
57	Schedule 1 Enter Standby	0000 to 2359	—:—
58	Schedule 1 Exit Standby	0000 to 2359	—:—
60	Schedule 2 Heaters On (See Note A)	0000 to 2359	—:—
61	Schedule 2 Heaters Off (See Note A)	0000 to 2359	—:—
62	Schedule 2 Enter Standby (See Note A)	0000 to 2359	—:—
63	Schedule 2 Exit Standby (See Note A)	0000 to 2359	—:—
65	Schedule 3 Heaters On (See Note A)	0000 to 2359	—:—
66	Schedule 3 Heaters Off (See Note A)	0000 to 2359	—:—
67	Schedule 3 Enter Standby (See Note A)	0000 to 2359	—:—
68	Schedule 3 Exit Standby (See Note A)	0000 to 2359	—:—
71	Schedule for Monday	0–1 (See Note B)	0 (disabled)
72	Schedule for Tuesday	0–1 (See Note B)	0 (disabled)
73	Schedule for Wednesday	0–1 (See Note B)	0 (disabled)
74	Schedule for Thursday	0–1 (See Note B)	0 (disabled)
75	Schedule for Friday	0–1 (See Note B)	0 (disabled)
76	Schedule for Saturday	0–1 (See Note B)	0 (disabled)
77	Schedule for Sunday	0–1 (See Note B)	0 (disabled)
NOTE A: Parameter is available only when the optional I/O expansion card is installed.			
NOTE B: Only control option 1 (Use Schedule 1) is available unless the optional I/O expansion card is installed. When the expansion card is installed, control options 2 through 7 are available. Refer to Appendix B for information about these control options.			



You can exit the setup mode at any time by pressing the **Setup** key.

Parameter numbers that are not applicable are skipped when you scroll through the operating parameter list in the left display.

When the right display is flashing, you can quickly set the value of the current parameter to its lowest possible value by simultaneously pressing both of the right-display scroll keys.

While in the setup mode, if no key is pressed for two minutes, the melter will return to the automatic scan mode.

You can also use the right-display scroll keys to enter or change a parameter's value or control option. After entering the parameter's number in the left display, press either of the right-display scroll keys to change the value or control option.

If password protection is enabled, the melter will return to the password protected mode whenever you exit the setup mode.

Appendix B, *Parameter 10*

Setpoint Temperature of the Tank, Hoses, and Guns

The melter is shipped from the factory with the tank setpoint temperature at 175 °C (350 °F) and the hose and gun setpoint temperatures at 0 degrees (turned off).

Before the melter can be used, a setpoint temperature must be assigned to the tank, hoses, and guns. Assign setpoint temperatures using any of the following methods:

- **Global**—The tank and all hoses and guns are set to the same setpoint temperature.
- **Global-by-component group**—All of the hoses or all of the guns are set to the same setpoint temperature.
- **Individual Component**—The setpoint temperature of the tank and each hose and gun is set individually.

Since most manufacturing processes will require the tank, hoses, and guns to be set to the same temperature, only the global method of assigning setpoint temperatures is described in this section. For information about the other two methods of assigning setpoint temperatures, refer to *Adjusting Component Temperatures* in Section 4, *Operation*.

As with operating parameters, you can also review past changes that were made to setpoint temperatures.

To assign a global setpoint temperature

1. Press and hold the **Tank** key for three seconds.
The left display flashes 1.
2. Scroll the left display to 0.
The right display indicates all dashes (----) and the LEDs on the tank, hose, and gun keys turn green.
3. Press a right-display scroll key.
The right display flashes.

4. Use the right-display scroll keys to enter the setpoint temperature recommended by the manufacturer of the hot melt.

Refer to the technical data sheet provided by the manufacturer of the hot melt to determine the optimal setpoint temperature.

5. Press the **Tank** key.

Each component begins to heat or cool to the new global setpoint temperature and the melter returns to the automatic scan mode.

When all of the components reach the global setpoint temperature, the ready LED turns on (green).

Review Parameter and Setpoint Temperature Changes

The melter stores in a change history log, a record of the last ten changes that were made to either operating parameters or setpoint temperatures. Since the log only stores ten changes, old log entries are overwritten beginning with the first log entry, by the eleventh and following log entries.

To review the change history log

1. Press the **Setup** key.

Operating parameter 1 flashes in the left display.

2. Press the left-display scroll key to change the display to parameter 3 (the change history log).

The following occurs:

- If the last change was to an editable parameter, all of the component key LEDs remain off.

or

- If the last change was to a setpoint temperature, the LED on the associated component key(s) turns on.

and

- The right display indicates the four-digit log entry associated with the *last* change that was made.

Table 3-8 provides the meaning, from left to right, of each digit in the log entry. Following the table are two example log entries.

3. Press a right-display scroll key to review each of the remaining nine log entries. Each press of a scroll key displays a progressively older log entry.
4. Press the **Setup** key to return to the automatic scan mode.

Table 3-8 Change History Log

First Digit	Second Digit	Third and Fourth Digits			
P (Parameter)		<i>Indicates the number of the parameter that was changed</i>			
S (Setpoint)	-	<i>Are used in conjunction with the LEDs on the component keys to indicate the location and method of a setpoint temperature change.</i>			
		When this LED is on..	And the Fourth Digit Indicates..	The change was to..	And the Method of Change was..
		Tank Key	1	The tank	Individual
		Hose Key	1– 6	A single hose	Individual
		Gun Key	1– 6	A single gun	Individual
		All Keys	0	All components	Global
		Hose Key	0	All hoses	Global-by-component
		Gun Key	0	All guns	Global-by-component

Change History Log Examples

Example 1:

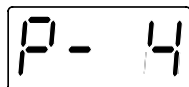

Parameter 4 (ready delay) was changed.

Example 2:

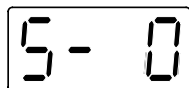

If the LED on the gun key is on, then this display would indicate that the global-by-component method was used to change the temperature of the guns.



Unused log entries in the change history log are indicated by "P-_" in the right display.

To view how many heater hours have elapsed since a specific change (displayed) was made, simultaneously press both of the right-display scroll keys.

Installing Melter Inputs

Mesa melters are equipped with a single standard input that is pre-configured to allow the user to enable or disable the Automatic Standby feature of the melter.

When the optional I/O expansion card is installed (refer to Section 7, *Parts*), the input capacity of the melter can be increased to 10 inputs. With the optional I/O expansion card installed each input can be configured to provide one of the following control options:

- Place the melter into the standby mode
- Turn the heater on and off
- Enable or disable a specific hose or gun
- Turn the pump on and off

The inputs require a 10 to 30 VDC signal voltage. The inputs are not polarity-sensitive.



WARNING: The operator can override the melter inputs by using the control panel function keys. Ensure that the control logic for any external device that sends an input signal to the melter is programmed to prevent the creation of an unsafe condition in the event that the operator overrides an external input to the melter.

To wire inputs to the melter

1. Route a 2-conductor signal cable from the control equipment to the melter and through the PG-16 penetration on the side or floor of the electrical compartment. Use rigid or flexible conduit or a suitable strain relief to protect the cable from the sharp edge of the conduit penetration.

NOTE: When using the optional I/O expansion card, use a multi-wire cable suitable for NEC class1 remote control and signaling circuits. To reduce the possibility of electrical shorting, route the cable so that it does not touch nearby circuit boards.

See Figure 3-10.

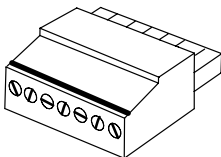

Connector P/N 277909

2. Connect the input wires to terminals 8 and 9 on connector P/N 277909. When using the optional I/O expansion card, refer to Table 3-9 for information about terminating multiple inputs.

NOTE: Connector P/N 277909 is physically keyed to prevent it from being used in place of connector P/N 277908, which has terminals numbered 1 through 7.

3. Plug the connector (P/N 277909) into the top receptacle of terminal XT7, which is located on the expansion board.

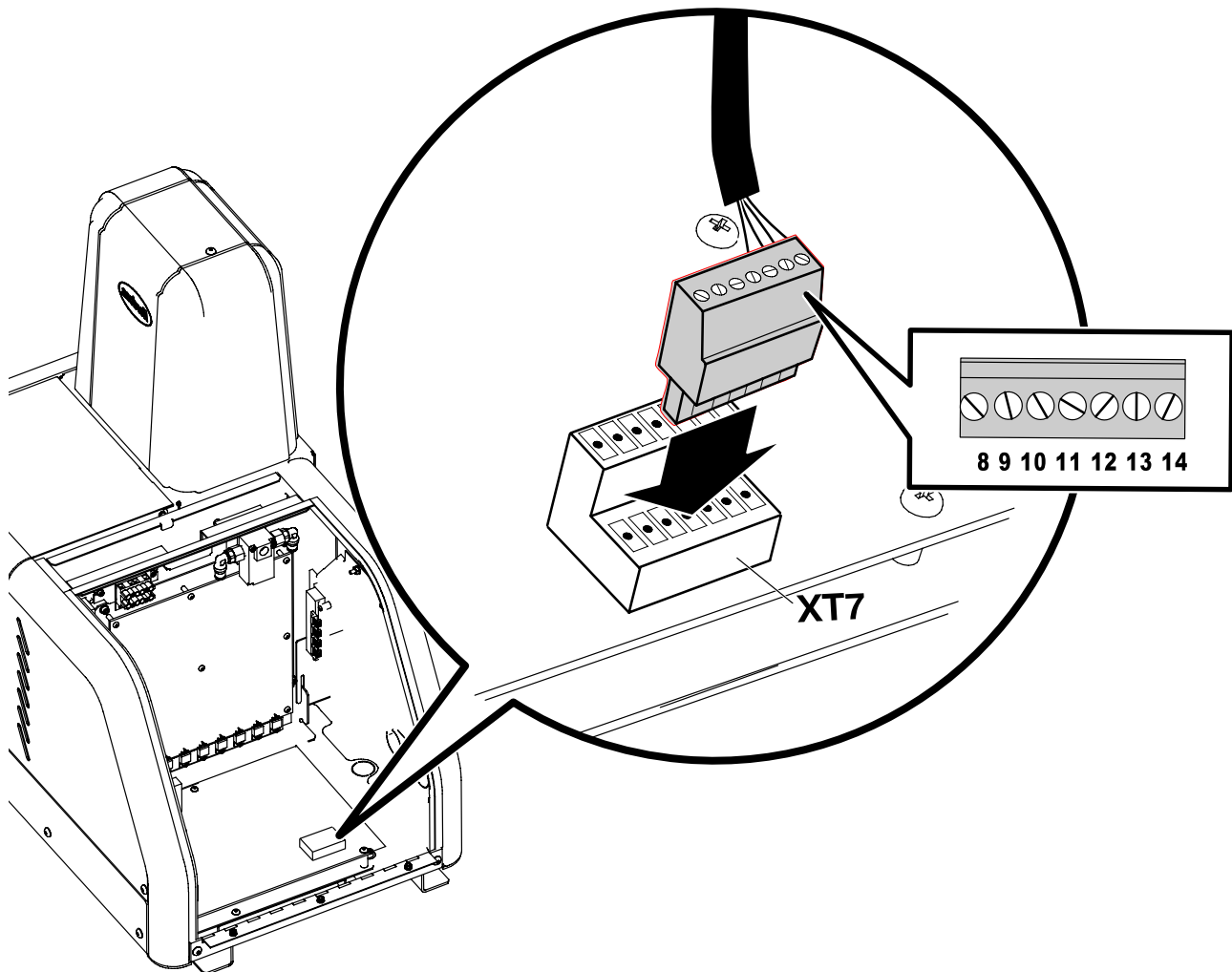

Figure 3-10 Standard wiring inputs

To set up the optional inputs

When the optional I/O expansion card is installed, each input can be configured to perform one of five control options. Refer to Table 3-9 for information about the available control options. Refer to *Setting Up the Melter* earlier in this section, for information about how to select operating parameters and edit parameter control options.

Installing Melter Inputs *(contd)*

Table 3-9 Input Data

Input	Terminals	Operating Parameter	Control Option	Note
<i>Standard Inputs (XT-7 on the expansion board)</i>				
1	8 and 9	30	0 - Input Disabled 1 - Standby On/Off 2 - Heaters On/Off 3 - Pump 1 Enable/Disable 4 - Hose/Gun 1 Enable/Disable 5 - Hose/Gun 2 Enable/Disable 6 - Hose/Gun 3 Enable/Disable 7 - Hose/Gun 4 Enable/Disable 8 - Hose/Gun 5 Enable/Disable 9 - Hose/Gun 6 Enable/Disable 10 – Automatic Standby (Default)	A A A A A A A A A B
2	10 and 11	31	0 - Input Disabled 1 - Standby On/Off (Default) 2 - Heaters On/Off 3 - Pump 1 Enable/Disable 4 - Hose/Gun 1 Enable/Disable 5 - Hose/Gun 2 Enable/Disable 6 - Hose/Gun 3 Enable/Disable 7 - Hose/Gun 4 Enable/Disable 8 - Hose/Gun 5 Enable/Disable 9 - Hose/Gun 6 Enable/Disable	A A A A A A A A A
3	12 and 13	32	Same as parameter 31 (Default=2)	A
4	7 and 14	33	Same as parameter 31 (Default=4)	A
<i>Continued...</i>				

Table 3-9 Input Data (contd)

Input	Terminals	Operating Parameter	Control Option	Note
<i>Optional Inputs (TB1 on the optional I/O expansion card)</i>				
5	11 and 12	34	Same as parameter 31 (Default=0)	C, D
6	13 and 14	35	Same as parameter 31 (Default=0)	C, D
7	15 and 16	36	Same as parameter 31 (Default=0)	C, D
8	17 and 18	37	Same as parameter 31 (Default=0)	C, D
9	19 and 20	38	Same as parameter 31 (Default=0)	C, D
10	9 and 10	39	Same as parameter 31 (Default=0)	C, D
<p>NOTE A: Option is not available unless the optional I/O expansion card is installed.</p> <p>B: Without the optional I/O expansion card, Input 1 is pre-configured to place the melter into the automatic standby mode. Operating parameter 24 must be enabled (set to a value of 1) in order for the input signal to be recognized. When parameter 24 is enabled, the heaters will turn off after 1 minute.</p> <p>C: Parameters 34 through 39 are reserved for the inputs created when the optional I/O expansion card is installed. Refer to Appendix B, <i>Operating Parameters</i>, for more information.</p> <p>D: Refer to the instruction sheet provided with the optional I/O expansion card for wiring information.</p>				

Installing Melter Outputs

The melter is equipped with three fixed outputs.

- Output 1—The melter is ready
- Output 2—The melter is ready *and* the pump is on
- Output 3—A fault has occurred

The output capacity of the melter can be expanded to 7 outputs by installing the optional I/O expansion card. When the expansion card is installed, each of the seven outputs can be configured to perform one of six functions. Refer to Section 7, *Parts*, for information about the optional I/O expansion card.

All outputs contacts are rated at 240 VAC 2 A or 30 VDC 2 A. All contacts are normally open when the melter is turned off.

To connect an output to the melter

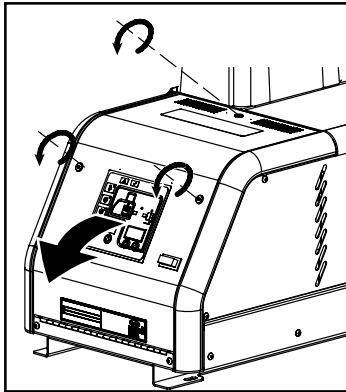

Opening the electrical enclosure door

1. Route a 2-, 4, or 6-conductor signal cable from the control equipment to the melter, through the PG-16 penetration on the floor of the electrical compartment. Use rigid or flexible conduit or a suitable strain relief to protect the cable from the sharp edge of the conduit penetration.

NOTE: When using the optional I/O expansion card, use a multi-wire cable suitable for NEC class1 remote control and signaling circuits. To reduce the possibility of electrical shorting, route the cable so that it does not touch nearby circuit boards.

See Figure 3-11.

2. Connect each pair of output wires to the appropriate terminals (1 through 7) on connector P/N 277908. The connector is provided in the installation kit. Table 3-10 lists the terminal numbers that correspond to each output.

NOTE: Terminal number 7 on connector P/N 277908 is reserved for input number four. Connector P/N 277908 is physically keyed to prevent it from being used as connector P/N 277909, which has terminals numbered 8 through 14.

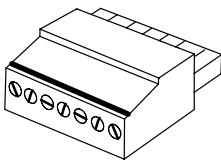

Output connector P/N 277908

3. Plug connector P/N 277908 into the bottom receptacle on terminal XT7, which is located on the expansion board.

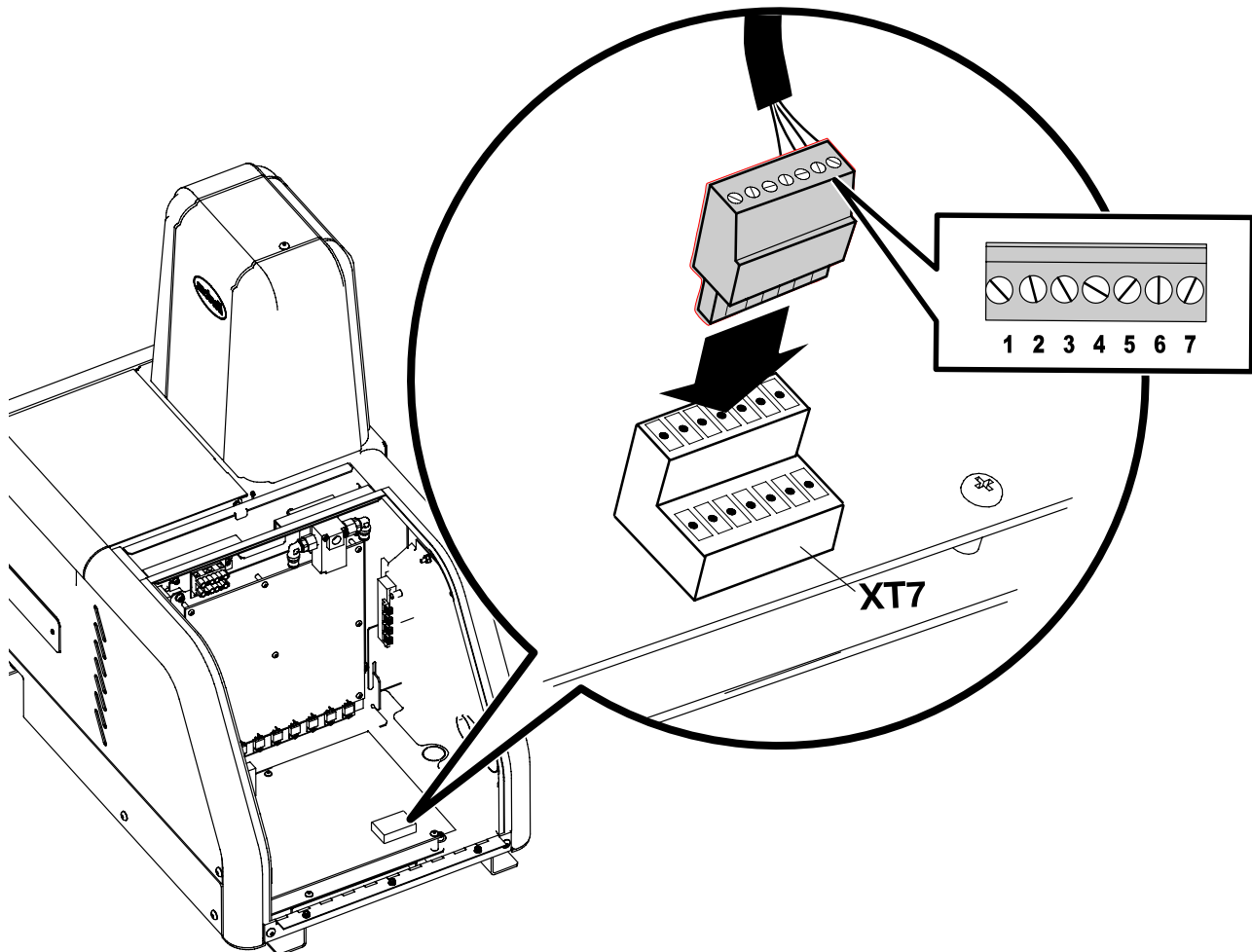

Figure 3-11 Standard wiring outputs

To set up an output

On a standard Mesa melter, the function of each of the three standard outputs is fixed. However, when the optional I/O expansion card is installed, each output can be configured to perform one of six functions. Table 3-10 lists the available control options. Refer to *Setting Up the Melter* earlier in this section for information about how to select operating parameters and edit parameter control options.

Installing Melter Outputs *(contd)*

Table 3-10 Output Data

Output	Terminals	Operating Parameter	Control Options	Note
<i>Standard Outputs (XT-7 on the expansion board)</i>				
1	1 and 2	40	0 - Output Disabled 1 - Ready (Default) 2 - Ready <i>and</i> the Pump is On 3 - Fault 6 - Alert	F A A, F B, F C, F
2	3 and 4	41	0 - Output Disabled 1 - Ready 2 - Ready <i>and</i> the Pump is On (Default) 3 - Fault 6 - Alert	F A, F A B, F C, F
3	5 and 6	42	0 - Output Disabled 1 - Ready 2 - Ready <i>and</i> the Pump is On 3 - Fault (Default) 6 - Alert	F A, F A, F B C, F
<i>Optional Outputs (TB1 on the optional I/O expansion card)</i>				
4	1 and 2	43	Same as parameter 40 (Default=0)	E
5	3 and 4	44	Same as parameter 40 (Default=0)	
6	5 and 6	45	Same as parameter 40 (Default=0)	
7	7 and 8	46	Same as parameter 40 (Default=0)	
<p>NOTE A: When control option condition occurs, contacts close. Contacts are normally open when power is off.</p> <p>B: When control option condition occurs, contacts open. Contacts are normally open when power is off.</p> <p>C: Control option 6 provides an output signal when a potential fault is detected. If control option 3 and 6 are both used, then both a fault output and an alert output signal will be present when the fault LED turns on.</p> <p>D: Parameters 43 through 45 are reserved for the outputs created when the optional I/O expansion card is installed. When card is installed all options except option 5 are available. Refer to Appendix B, <i>Operating Parameters</i>, for more information.</p> <p>E: For wiring information, refer to the instruction sheet that is provided with the optional I/O expansion card.</p> <p>F: Option is only available for this output when the optional I/O expansion card is installed.</p>				

Installing Optional Equipment

Each item of optional equipment is shipped with instructions for installing and operating the equipment. Refer to Section 7, *Parts*, for equipment part numbers.

Connecting a Gun Driver, Pattern Controller, or Timer

If applicable, complete the melter installation by connecting the guns to the desired gun driver, pattern control, or timer. Refer to the product manual provided with the device for information about installing and operating the equipment.

Flushing the Melter



WARNING: Risk of Burns! New melters contain a small quantity of low-viscosity test fluid. Test fluid may splatter when discharged under high pressure. Before flushing the melter, ensure that the pressure control valve is set to low pressure.

Before using the melter for production, it should be flushed to remove any residue left over from factory-testing. Flushing the melter is accomplished by processing a minimum of one tank volume of hot melt through the melter, hoses, and guns.

Refer to Section 4, *Operation*, for information about filling the tank and operating the melter.

Refer to Section 5, *Maintenance*, for detailed instructions about flushing the melter.

This page intentionally left blank.

Section 4

Operation



WARNING: Allow only personnel with appropriate training and experience to operate or service the equipment. The use of untrained or inexperienced personnel to operate or service the equipment can result in injury, including death, to themselves and others, and damage to the equipment.

This section provides information about the following operator-level tasks:

- Filling the melter tank
- Starting the melter
- Monitoring melter operation
- Adjusting the operating temperature of heated components
- Using the melter function keys
- Shutting the melter down

Most of the controls described in this section are located on the control panel. Refer to *Key Components* in Section 2, *Introduction*, for the location of the controls and indicators described in this section.

Additional Information



This section presents operating procedures in their most commonly used form. Procedural variations or special considerations are explained in the additional information table that follows most procedures. Where applicable, some table entries also contain cross-reference information. Additional information tables are indicated by the symbol shown to the left.

Filling the Tank

Before filling the tank, confirm that the hot melt material is compatible with the melter. Refer to *Intended Use* in Section 2, *Introduction*, for information about hot melt materials that should not be used in Mesa melters.

To fill the tank



WARNING: Hot! Risk of burns! Use a scoop to fill the tank with hot melt. Never use your bare hands. Using your bare hands to fill the tank may result in personal injury.

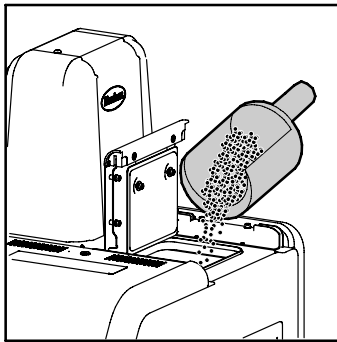

Filling the tank

1. Open the tank lid.
2. Use a scoop to fill the tank with hot melt. Table 4-1 lists the tank capacity of each Mesa melter.

NOTE: Nordson Corporation recommends that the tank be kept at least one-half full while the melter is operating.

3. Close the tank lid when you are finished filling the tank.

Table 4-1 Tank Capacity

Model	Capacity*		
	Liters	Kilograms	Pounds
M4	3.6	3.6	8
M6	5.4	5.4	12
M9	8.6	8.6	19
M14	13.6	13.6	30

*Assumes a hot melt with a specific gravity of 1

Starting the Melter

Before starting the melter for the first time, confirm that the

- melter is fully installed including any required inputs and outputs, gun drivers, pattern controllers, or timers.
- melter's operating parameters are set up to support the current manufacturing process.

Refer to Section 3, *Installation*, if any of the items listed above are not complete.

To start the melter

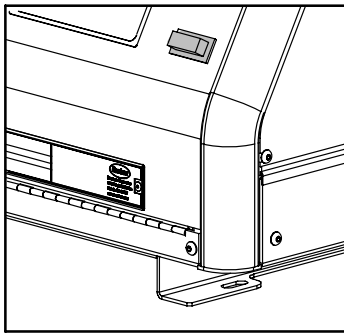

Control switch (on/off)

1. Switch the melter on.

The melter:

- Tests the control panel LEDs
 - Turns on the heaters (the heaters LED turns green)
 - Begins to automatically scan through and display the actual temperature of the tank and each hose and gun that has a setpoint temperature that is greater than zero degrees. The sequence of the automatic scan is: tank, each hose and gun pair, and then back to the tank.
 - Turns on the ready LED (green) when the tank and all of the hoses and guns are within 3 °C (5 °F) of their assigned setpoint temperature.
2. Turns the pump on:
 - if the clock is set (optional)
 - if the ready delay time has expired (optional)
 - if the melter reaches ready and neither the clock or the ready delay time are set

To start the melter (contd)



If the melter is switched on when the temperature of the tank is 27 °C (50 °F) or greater below its assigned setpoint temperature (cold start condition), the ready LED will not turn on until the ready delay (defined when the melter was set up) has elapsed.

Appendix B, parameter 4

The time remaining on the ready delay (in minutes) appears in the right display at the end of every scan cycle. When only one minute remains in the ready delay time, the right display counts down in seconds.

Appendix B, parameter 4

You can by-pass the ready delay time by pressing the **Heaters** key twice.

The appearance of F4 in the right display immediately after the melter is switched on indicates a problem with the melter's processor or main board.

Section 4, *Monitor Melter Faults*

The appearance of F1 in the right display immediately after starting the melter indicates that a hose or gun cordset may be loose or disconnected.

Section 6, *Troubleshooting*

If the seven-day clock feature was set up and turned on when the melter was last switched off, the clock will automatically turn on the next time the melter is switched on.

Section 4, *Using Melter Function Keys*

If a power failure occurs, the melter will restart in its normal heat-up cycle, even if the heaters were off or the melter was in standby prior to the power failure. If the seven-day clock was on prior to the power failure, the melter will restart in the mode dictated by the clock schedule at the time the melter restarts.

Monitoring the Melter

The melter provides indicators that allow you to:

- Quickly confirm that the melter is operating correctly
- Monitor the actual temperature of the tank group and each hose and gun
- Identify melter faults

The melter automatically determines the number and location of all hoses and guns that are connected to it.

Confirm that the Melter is Operating Correctly

The ready LED turns on (green) when all of the heated components are within 3 °C (5 °F) of their setpoint temperature.

The ready LED will not turn on, or will turn off, if any of the following events occur:

- The ready delay is still counting down.
- The operator places the melter into the standby mode.
- The seven-day clock places the melter in the standby mode.
- There is a fault (the fault LED will turn on).
- The heaters are turned off.

Refer to *Monitor Melter Faults* and *Using Melter Function Keys* later in this section for information about melter faults and using the seven-day clock and standby functions. Refer to Appendix B, parameter 4, for information about the ready delay.



Heated components with a setpoint temperature of zero degrees are skipped during the automatic scan cycle.

The time remaining on the ready delay appears in the right display at the end of each scan cycle.

Appendix B, parameter 4

You can override the seven-day clock at any time. If the clock has turned the heaters off, pressing the heaters key will turn the heaters back on. If the clock has placed the melter into the standby mode, pressing the standby key will return the heated components to their assigned setpoint temperature.

Section 4, *Using Melter Function Keys*

Monitor Component Temperatures

You can check the actual temperature of each heated component—the tank and each hose and gun—using the automatic scan mode or by manually selecting and checking each component.

By default, the melter remains in the automatic scan mode except when:

- The melter is placed into the setup mode
- The setpoint temperature of all hoses and guns is set to zero degrees
- A fault occurs

To check component temperatures using the automatic scan mode

1. When the ready LED is on, observe the LEDs on the component keys.
2. When the LED on the key that represents the desired component group (tank, hose, or gun) turns on, observe the left display until it indicates the position number of the specific component you want to check.
3. When the position number of the desired component appears in the left display, observe the right display to determine the component's actual temperature.

To manually check a component's temperature

1. Press the key (tank, hose, or gun) that represents the component group you want to check.

The automatic scan stops and the left display indicates the number of the first sequential component in the selected component group. The right display indicates the component's actual temperature.

NOTE: When the tank key is pressed, the left display does not indicate a component number (blank display).

2. If the first sequential component is not the component you want to check, use the left-display scroll key to change to the correct component number.

The right display indicates the actual temperature of the selected component.

3. Press the **Setup** key twice to return to the automatic scan mode.



When you scroll the left display past the number of the last sequential component in a component group, the number of the first sequential component in the next component group appears in the left display.

The melter will return to the automatic scan mode two minutes after the last key is pressed.

The default unit for temperature display is degrees Celsius (C). This may be changed to degrees Fahrenheit using operating parameter 20.

Appendix B, Parameter 20

The LEDs on each component key will change from green to yellow if any component in the component group drops more than 3 °C (5 °F) below its assigned setpoint temperature.

You can check the setpoint temperature of a component at any time, by pressing the right-display UP scroll key. Holding down the scroll key while the melter is in the automatic scan mode reveals the setpoint of each component that is scanned.

Monitor Melter Faults

The melter alerts the operator to the faults listed in Table 4-2. Faults affect the melter in one of three ways: the heaters turn off; the heaters remain on, but the fault condition persists; or the melter stops functioning.

When a fault occurs, you must diagnose and correct the fault condition and then place the melter back into operation. You can use the fault log to determine the type, order, and relative time of the last ten faults.

Table 4-2 Melter Faults

Display Code/Sub-code	Name	Affect on Melter	Cause	Corrective Action
F1/None	RTD	Heaters turn off	The RTD for the component indicated has failed or the component was disconnected from the melter.	Replace RTD Check hose/gun connections See flowchart T.2
F2/None	Under temperature	Heaters turn off	The actual temperature of the component indicated has dropped below the under temperature delta, which was set using parameter 22.	Check for conditions that may cause a drop in ambient temperature Replace RTD See flowchart T.2
F3/None	Over temperature	Heaters turn off	The actual temperature of the component indicated has increased beyond the over temperature delta, which was set using parameter 21.	Replace RTD See flowchart T.2
F4/1	RAM test	Melter stops functioning	Internal RAM failure	Replace CPU
F4/2	Internal Clock time	Heaters remain on, but fault condition persists	Internal clock failure	Replace CPU
F4/3	RAM backup battery	Clock does not function	Insufficient voltage from RAM backup battery	Replace CPU
F4/4	Internal clock battery backed RAM	Heaters remain on, but fault condition persists	Battery-backed RAM failure	Replace CPU
F4/5	Internal clock battery	Heaters remain on, but fault condition persists	Battery-backed RAM battery dead	Replace CPU

Continued...

Table 4-2 Melter Faults (contd)

Display Code/Sub-code	Name	Affect on Melter	Cause	Corrective Action
F4/6	Analog-to-digital	Melter stops functioning	RTD analog-to-digital converter failed	Replace main board or CPU
F4/7	Analog-to-digital calibration	Melter stops functioning	Failed hose or gun RTD analog-to-digital converter could not be calibrated (grounded RTD in system)	Replace hose or gun. Note: Set setpoint to zero to avoid F1 fault. Replace main board, ribbon cable, or CPU.
F4/8	Main board feedback	Melter stops functioning	Communication failure between main board and CPU	Replace main board, ribbon cable, or CPU
F4/A	Thermostat	Melter stops functioning	Tank or manifold thermostat is open	Replace thermostat, J7 harness, or main board
F4/C	Expansion board connection	Melter stops functioning	Ribbon cable P/N 1026662 is not connected at J1 on the main board and/or at J2 on the expansion board	Check the ribbon cable connections and make connections as applicable.
F4/d	Communications with optional I/O card	Heaters remain on, but fault condition persists	Communication failure between CPU and the optional I/O card	Replace the I/O card or CPU

Monitor Melter Faults (contd)

How F1, F2, and F3 Faults are Handled

When the melter detects an F1, F2, or an F3 fault:

1. The automatic scan stops and the melter begins to monitor the potential fault for up to two minutes. The ready and heater LEDs remain on during the two-minute time period. If, at any time during the two-minute period, the melter detects that the fault condition no longer exists, the melter will return to the automatic scan mode.
2. The LED on the affected component key (tank, hose, or gun) turns on to indicate the type of component that has failed or is failing.
3. The right display indicates the type of fault (F1, F2, or F3).
4. The left display indicates, as follows, the component that has failed or is failing.
 - If the LED on the tank key is on, the left display will indicate 1 for the tank.
 - If the LED on the hose or gun key is on, the left display will indicate the number of the affected hose or gun.
5. If the fault condition still exists at the end of the two-minute monitoring period, the ready LED will turn off, the red fault LED will turn on, the heaters turn off, and the melter records the fault in the fault log. Refer to *To review the fault log* later in this section.

How F4 Faults are Handled

When the melter detects an F4 fault:

1. The ready LED turns off and the red fault LED turns on.
2. All of the component key LEDs (tank, hose, and gun) turn off.
3. The right display indicates F4.
4. The left display indicates a sub-code. Sub-codes classify the fault as being fatal or nonfatal. The affect on the melter of each of these two classes of F4 faults is:

Fatal—The fault LED turns on and stays on and the melter stops functioning completely.

Nonfatal—The fault LED turns on for five seconds, but the heaters and pump continue to operate normally. Nonfatal faults affect the internal clock and the optional I/Os.

Refer to Section 6, *Troubleshooting*, for information about diagnosing F4 faults.

5. The melter records the fault in the fault log. Refer to *To review the fault log* later in this section.

To put the melter back into operation

1. Diagnose and correct the fault condition. Refer to Section 6, *Troubleshooting*, for information about diagnosing and correcting fault conditions.

NOTE: When a fatal F4 fault exists, the control switch will not function. Remove power to the melter at the local disconnect switch.

2. Return the melter to the automatic scan mode by pressing the **Setup** key twice.
3. Cycle the Control switch off and then on.
4. Press the **Heater** key to turn on the heaters.



To view the temperature of a heated component when an F2 or F3 fault exists, simultaneously press and hold both of the right-display scroll keys.

When an F1 fault code appears, you can determine whether the fault was caused by an open or a shorted RTD by simultaneously pressing both of the right-display scroll keys. If the right display indicates OP, the RTD is open, if it indicates SH, the RTD has shorted.

If, for any reason, a component reaches 235 °C (458 °F), an immediate F3 fault will occur (no two-minute monitoring period).

If F4 appears in the right display when you press the clock key, the internal clock function has failed.

To review the fault log

1. Press and hold the **Setup** key.
The automatic scan stops and operating parameter 1 appears in the left display.
2. Scroll the left display to parameter 2 (the fault log).
The right display indicates the last fault that occurred as follows:
 - If the last fault was an F1, F2, or F3 fault, then the LED on the affected component key turns yellow.
 - If the last fault to occur was an F4 fault, then the LEDs on all of the component keys turn off.
 - The right display indicates the log entry for the last fault to occur. Table 4-3 provides the meaning of each digit in the log entry. Following the table are two example fault log entries.
3. Press the right-display scroll key to review each of the remaining nine log entries. Each press of the scroll key displays a progressively older log entry.
NOTE: The fault log only stores the last ten faults. After ten faults occur, the existing log entries are overwritten, beginning with the oldest entry, by the eleventh and following log entries.
4. Press the **Setup** key to return to the automatic scan mode.

Table 4-3 Fault Log

First Digit	Second and Third Digits	Fourth Digit
<p><i>Component:</i></p> <p>1 = Tank or hose/gun 1 2 = Hose 2 or gun 2 3 = Hose 3 or gun 3 4 = Hose 4 or gun 4 5 = Hose 5 or gun 5 6 = Hose 6 or gun 6</p>	<p>- F</p>	<p><i>Type of fault:</i></p> <p>0 = Unused log entry 1 = RTD (open or short) 2 = Component under temperature 3 = Component over temperature 4 = Processor or electrical failure</p>

Fault Log Examples

Example 1:



Example 2:

Fault Log Examples (contd)

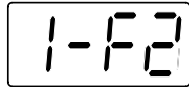

If the LED on the tank key were on, this log entry would indicate that the tank is under temperature. If the LED on the hose key were on, this log entry would indicate that hose 1 is under temperature.



To view the number of heater hours that have elapsed since a log entry was created, simultaneously press both of the right-display scroll keys. The hours are indicated in the right display.

The melter will return to the automatic scan mode if the fault log is left open for a period of two minutes without any key being pressed.

When an F1 fault is the result of a hose/gun pair being disconnected from the melter, two fault log entries are created. The first entry is for the gun and the second entry is for the hose.

This page intentionally left blank.

Adjusting Component Temperatures

You can adjust the setpoint temperature of heated components using the following methods:

- **Global**—The tank and all hoses and guns are set to the same setpoint temperature.
- **Global-by-component group**—All of the hoses or all of the guns are set to the same setpoint temperature.
- **Individual Component**—The setpoint temperature of the tank and each hose and gun is adjusted independently.

Before adjusting setpoint temperatures, confirm that each hose/gun pair is connected to the correct hose/gun receptacle. For example, hose/gun pair 1 should be connected to the receptacle 1.

To adjust setpoint temperatures using the global method

1. Press and hold the **Tank** key for three seconds.
The left display flashes 1.
2. Scroll the left display to 0 (flashing).
The right display indicates all dashes (----) and the LEDs on all of the component keys turn green.
3. Press a right-display scroll key.
The right display flashes.
4. Use the right-display scroll keys to enter the setpoint temperature recommended by the manufacturer of the hot melt. Refer to the technical data sheet provided by the manufacturer of the hot melt to determine the optimal setpoint temperature.

NOTE: If the right-display scroll keys have no effect on the right display, the melter is password protected. You must enter a valid password before you can change setpoint temperatures. Refer *Enter the Melter Password*, later in this section.

5. Press the **Tank** key.
All components begin to heat or cool to the new global setpoint temperature. When all of the components reach their setpoint temperature, the ready LED turns on (green).

To adjust the setpoint temperature using the global-by-component method

1. Press and hold the **Hose** or **Gun** key for three seconds.
The left display indicates the number of the first sequential hose or gun. The right display indicates the current setpoint temperature of the hose or the gun.
2. Scroll the left display to 0.
The right display indicates all dashes (----).
3. Press a right-display scroll key.
The right display flashes.
4. Use the right-display scroll keys to enter the setpoint temperature recommended by the manufacturer of the hot melt. Refer to the technical data sheet provided by the manufacturer of the hot melt to determine the optimal setpoint temperature.
NOTE: If the right-display scroll keys have no effect on the right display, the melter is password protected. You must enter a valid password before you can change setpoint temperatures. Refer to *Entering the Melter Password* later in this section.
5. Press the left-display scroll key.
The hoses or the guns begin to heat or cool to their new setpoint temperature.

To adjust the setpoint temperature of an individual component

1. Press and hold the **Tank**, **Hose**, or **Gun** key for three seconds.
If the tank key was pressed, the left display indicates 1 (Flashing). If a hose or gun key was pressed, the left display indicates the number of the first sequential hose or gun (Flashing). The right display indicates the current setpoint temperature of the component indicated in the left display.

2. Scroll the left display to the number of the desired component.
The right display indicates the current setpoint temperature of the component that you selected in the left display.

3. Press a right-display scroll key.
The right display flashes.

4. Use the right-display scroll keys to enter the setpoint temperature recommended by the manufacturer of the hot melt. Refer to the technical data sheet provided by the manufacturer of the hot melt to determine the optimal setpoint temperature.

NOTE: If the right-display scroll keys have no effect on the right display, the melter is password protected. You must enter a valid password before you can change setpoint temperatures. Refer to *Entering the Melter Password* later in this section.

5. Do *one* of the following:

- To register the new setpoint temperature and then move on to change the setpoint temperature of the next sequential component, press the left-display scroll key and then repeat steps 4 and 5.
- To register the new setpoint temperature and return to the automatic scan mode, go to step 6.

6. Press any component key (tank, hose, or gun).
The selected component begins to heat or cool to its new setpoint temperature.



If you enter a valid setpoint temperature for a hose/gun that is not connected to the melter or if you enter a setpoint temperature that is out of range, the right display will indicate dashes (----) for three seconds and then change back to the original setpoint temperature.

When the right display is flashing, you can quickly change the current setpoint temperature to 0 degrees (off) by simultaneously pressing both of right-display scroll keys.

After removing a hose or a gun, use the individual component method of setpoint temperature adjustment to set the component's temperature to zero degrees (off). This will avoid causing an F1 fault when a hose or gun is added.

The factory setpoint temperature of the tank is 175 °C (350 °F). The factory setpoint temperature of all others components is zero degrees (off).

When the units of temperature is set to degrees Celsius, the minimum and maximum setpoint temperatures are 40 °C and 230 °C. When the units of temperature are set to degrees Fahrenheit, the minimum and maximum setpoint temperatures are 100 °F and 450 °F.

When using the scroll keys to adjust a setpoint temperature, the right display automatically increments between 0, 175, and 230 °C or between 0, 350, and 450 °F.

The melter will exit the setup mode and return to the automatic scan mode two minutes after the last key is pressed.

A global setpoint temperature of zero degrees (Celsius or Fahrenheit) turns all components off.

When scrolling through component numbers in the left display, component numbers that are associated with unused hose/gun receptacles are skipped.

The melter stores a record of the last ten changes made to the setpoint temperatures (and operating parameters) in the change history log.

*Section 3, Installation, Review
Parameter and Setpoint Temperature
Changes*

Enter the Melter Password

If the melter is password protected, a valid password must be entered before any setpoint temperature or melter parameter can be changed.

To enter a melter password

1. Press the **Setup** key.

The left display indicates parameter 0 (flashing) and the right display indicates 4000.

2. Use the right display scroll keys to set the correct password.

3. Press the left display scroll key.

One of the following occurs:

- If the password is correct, the left display indicates parameter 1.
- If the password is incorrect, the left display remains at 0 and the right display momentarily indicates dashes (---) and then returns to 4000.

If the password is incorrect, re-enter it and then press the left display key.



The melter will automatically revert back to the password-protected mode two minutes after the last key press (any key). To force the melter back into the password protected mode before two minutes has elapsed, press the **Setup** key twice.

The melter password is created and enabled/disabled during system setup.

Setting Up the Melter in Section 3, *Installation*

Using Melter Function Keys

The control panel provides the following standard and special function keys:

Standard function keys

- Heater
- Setup

Special function keys

- Seven-day clock
- Standby



CAUTION: Unintentionally activating function keys can, under the correct circumstances, have undesirable effects on the melter or the manufacturing process. Only personnel who are familiar with the melter's setup should use the function keys. Improper use of the function keys can result in erratic process behavior or personal injury.

Heater Key

Use the heater key to manually turn the component heaters on and off. Pressing the heater key overrides the control (on or off) of the heaters by the seven-day clock feature. The LED on the heater key illuminates when the heaters are on.

When a fault occurs (refer to *Monitor Melter Faults* earlier in this section) the heaters automatically turn off. The heater key is used to turn the heaters back on after correcting a fault condition.

Setup Key

Use the setup key to place the melter into and take the melter out of the setup mode. When the melter is placed into the setup mode, the automatic scan stops and the left and right displays are used to select and read or edit operating parameters.

Seven-day Clock Key

Use the seven-day clock key to turn the melter's clock feature on and off. When the clock is on, the temperature of each heated component is automatically regulated based on a user-defined schedule. Mesa melters allow one standard clock schedule to be created.

NOTE: To accommodate daily shift work and non-working days, the number of available clock schedules may be increased from 1 to 3 by installing the optional Input/Output card available from Nordson Corporation.

When the clock schedule calls for the heaters to be on, the heaters are regulated at their pre-assigned setpoint temperatures. When the clock activates the standby mode, the setpoint temperature of each component is temporarily reduced by a pre-set standby delta.

Refer to Appendix B, *Operating Parameters, Seven-day Clock*, for information about setting up the seven-day clock and the standby delta.



If the melter is switched off while the clock is on, the clock will automatically turn back on the next time the melter is switched back on.

If the heaters are manually turned off at the time that a clock schedule calls for the heaters to be on, the heaters will not turn back on until the next clock schedule calls for them to be on.

Applies only when the optional I/O card is installed.

The clock will still operate when the melter is faulting or is in the setup mode.

If F4 appears in the right display when you press the clock key, the internal clock function has failed.

Section 7, *Troubleshooting*

Standby Key

Use the standby key to manually place the melter into, and take it out of, the standby mode. Using the standby mode during periods of time when the melter is inactive helps conserve energy and allows heated components to quickly return to their setpoint temperatures when the melter is once again needed.

When the melter is placed into the standby mode, the temperatures of all components are reduced down from their setpoint temperature by a pre-set standby delta. The melter will remain in the standby mode until the standby key is pressed or the function of one of the operating parameters takes the melter out of the standby mode.

Using the standby key overrides the control of the melter (on or off) by the seven-day clock or a remote input.

Refer to Section 3, *Installation, Setting Up the Melter*, and to Appendix B, *Operating Parameters*, for information about setting the standby delta and the standby timer.



The melter may also be set up to automatically enter the standby mode using a variety of operating parameters.

Appendix B, Parameters 25, 57, 62, and 67

Shutting Down the Melter

Shut the melter down when it will not be used for an extended period of time.

To shut the melter down

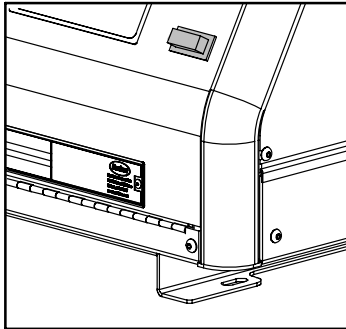

Control switch (on/off)

1. Switch the melter off.
2. Disable the guns as follows:
 - Air-operated guns: Turn off the air supply to the guns.
 - Electric guns: Turn off the gun driver, pattern controller, or timer.

Section 5

Maintenance



WARNING: Allow only personnel with appropriate training and experience to operate or service the equipment. The use of untrained or inexperienced personnel to operate or service the equipment can result in injury, including death, to themselves and others, and damage to the equipment.

Table 5-1 describes the preventive maintenance tasks required to keep Mesa melters operating within their specified limits and to prevent equipment malfunctions. For information about maintaining optional equipment that was supplied by Nordson, refer to the instructions provided with the equipment.

If the melter stops operating or is operating incorrectly, refer to Section 6, *Troubleshooting*, for information about diagnosing common problems and performing corrective maintenance.

Table 5-1 Preventive Maintenance Tasks

Task	Frequency	Reference
Relieving system pressure	Before performing any maintenance task that requires opening a hydraulic connection or port	<i>Relieving System Pressure</i>
Cleaning the exterior of the melter, hoses, and guns	Daily	<i>Cleaning the Melter</i>
Clean the manifold filter	Every 40 hours	<i>Cleaning a Standard Manifold Filter</i>
Flush the manifold filter	Every 8 hours	<i>Flushing a Standard Manifold Filter</i>
Cleaning the tank	<ul style="list-style-type: none"> • When changing the type or grade of hot melt • When excessive charring occurs 	<i>Cleaning the Tank</i>
Lock out external communications to the melter	Whenever performing maintenance on a melter that uses external inputs to control the pump.	<i>Locking Out External Communications</i>

Locking Out External Communications



WARNING: Disable external inputs with the melter before performing maintenance. Failure to disable external inputs with the melter can result in personal injury due to unexpected operation of the melter while performing maintenance.

To lockout external communications with the melter

- Set the control option for operating parameter 14 to 1 (enabled).

Refer to *Setting Up the Melter* in Section 3, *Installation*, for information about changing operating parameters.

Relieving System Pressure

System pressure must be properly relieved before you can safely proceed with many of the maintenance, troubleshooting, and repair procedures in this manual. Follow this procedure whenever you are instructed to relieve system pressure.

To relieve system pressure



WARNING: Hot! Risk of burns. Wear heat-protective clothing, safety goggles, and heat-protective gloves. Hot melt material may be released under pressure.

1. Ensure that the melter is at operating temperature.
2. Turn the air pressure regulator fully counterclockwise (no air).
3. Place a container under all guns and the manifold drain valve.
4. Trigger one or more guns until adhesive stops flowing.
5. Open the manifold drain valve and allow some adhesive to drain from the manifold.
6. Close the manifold drain valve.

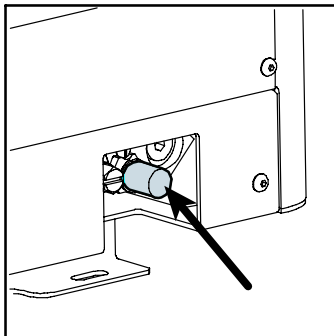

Manifold drain valve

Flushing a Standard Manifold Filter

Use this procedure to flush the manifold filter. Flushing the manifold filter removes excess dirt and charred material that can clog the system and cause poor system performance.



WARNING: Hot! Risk of burns. Wear heat-protective clothing, safety goggles, and heat-protective gloves. Hot melt material may be released under pressure.

To flush the filter

1. Ensure that the melter is at operating temperature.
2. Turn the air pressure regulator fully counterclockwise (no air).
3. Place containers under all guns and the manifold drain valve.



WARNING: System or material pressurized. Relieve system pressure. Failure to observe may result in serious burns.

4. Trigger the guns to relieve system pressure.
5. Open the manifold drain valve.
6. Increase the pump air pressure by turning the air pressure regulator clockwise until a clean, steady flow of adhesive flows from the drain. Allow adhesive to flow until no traces of char are present.
7. Return the air supply pressure to 0.
8. Close the manifold drain valve.
9. Return the air pressure to the normal operating setting.

Cleaning a Standard Manifold Filter

Use this procedure to clean the manifold filter. Cleaning the filter removes excess dirt and charred material that can clog the system and cause poor system performance.



WARNING: Hot! Risk of burns. Wear heat-protective clothing, safety goggles, and heat-protective gloves. Hot melt material may be released under pressure.

To clean the filter

1. Ensure that the melter is at operating temperature.
2. Flush the manifold filter. Refer to *Flushing a Standard Manifold Filter* in this section.



WARNING: System or material pressurized. Relieve pressure. Failure to observe may result in serious burns.

3. Relieve system pressure. Refer to *Relieving System Pressure* in this section.
4. See Figure 5-1. Loosen the filter using a wrench. A socket-type wrench is recommended.

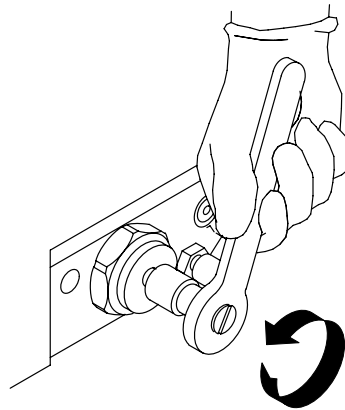

Figure 5-1 Loosening the filter

5. See Figure 5-2. Pull the filter assembly out of the manifold.

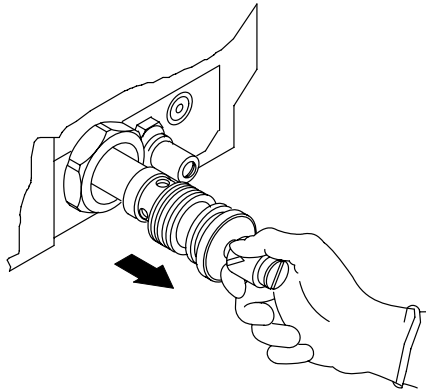

Figure 5-2 Removing the filter assembly

6. See Figure 5-3. Remove the screw in the back of filter assembly and separate the filter screen from the assembly.

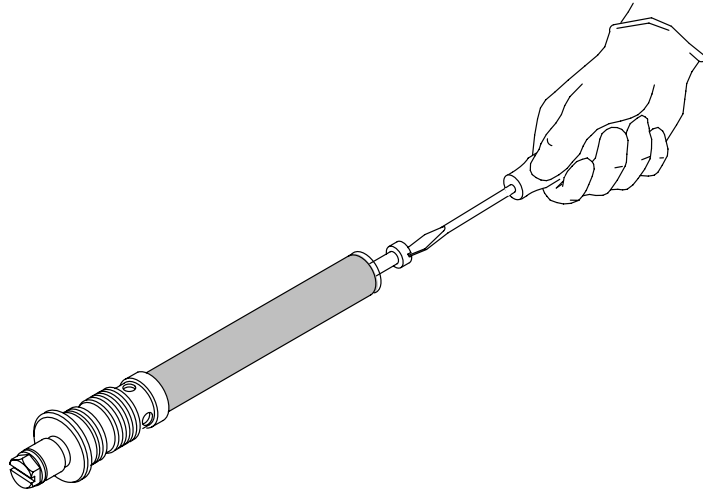

Figure 5-3 Removing the filter screen

Cleaning a Standard Manifold Filter *(contd)*

7. Use one of the following methods to clean the filter components.



WARNING: Risk of fire. Do not heat Nordson Type R cleaning fluid above 246 °C (475 °F). Do not heat cleaning fluid with an open flame or in an unregulated heating device (for example, a small pan on an unregulated hot plate). A fire hazard exists if an open flame or an unregulated heating device is used to heat cleaning fluid. Use only a controlled heating device (such as a small, deep fat fryer or thermostatically-controlled hot plate) to heat the fluid above the melting temperature of the hot melt material.

CAUTION: Do not use a metal brush to clean a manifold filter screen. Doing so can damage the screen and prevent the filter from operating properly.

- Place the components (except for the O-ring) in a container of Type R cleaning fluid and heat the fluid until it is above the melting point of the adhesive. Scrub the components with a fine-bristled brush. Remember to scrub the filter screen inside and out. Wipe the components with a clean, dry cloth.
 - Use a flameless, electric heat gun or compressed hot air to heat the components. Wipe the components with a clean, dry cloth.
 - Use an ultrasonic cleaner filled with cleaning fluid to soak the components, then wipe the components with a clean, dry cloth.
8. Inspect the filter screen and O-ring for damage. A dent or break in the filter screen mesh means that the screen is damaged beyond repair and should be replaced.

9. See Figure 5-4. Reassemble the filter.

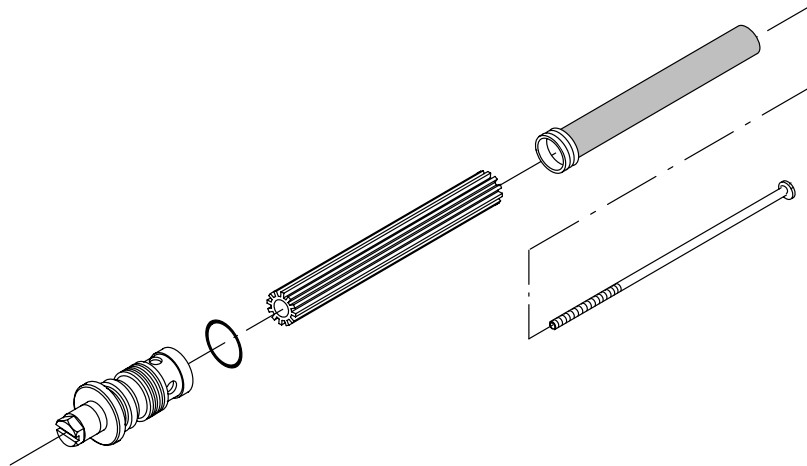

Figure 5-4 Assembling the manifold filter

CAUTION: Ensure that the melter is at operating temperature before reinstalling the filter. Cold material from the filter or manifold walls can cause the filter screen to collapse if it is tightened in a cold system.

10. Ensure that the melter is at operating temperature.
11. Slide the filter assembly into the manifold and tighten it until it is finger-tight only.
12. Follow these steps to flush the manifold again:
 - a. Open the manifold drain valve.
 - b. Turn the air pressure regulator fully counterclockwise to reduce the pump air pressure to 0.
 - c. Increase the pump air pressure by turning the air pressure regulator clockwise until a clean, steady flow of adhesive flows from the drain. Drain approximately 0.25 l (8 oz) of adhesive.
 - d. Return the pump air pressure to 0.
 - e. Close the manifold drain valve.
13. Tighten the filter assembly until it seats. Do not overtighten.
14. Return the pump air pressure to the normal operating setting.

Flushing the System

Use this procedure to periodically flush the system with hot melt material, a flushing material, or Type R cleaning fluid. System flushing removes excess dirt and charred material that can clog the system and cause poor system performance. You should also flush the system when you switch to a new type of hot melt material that is incompatible with the old material. If you are unsure whether the materials are compatible, contact your material supplier.

To Prepare for Flushing the System

1. Ensure that the melter is at operating temperature.



WARNING: System or material pressurized. Relieve system pressure. Failure to observe may result in serious burns.

2. Relieve system pressure. Refer to *Relieving System Pressure* in this section.
3. See Figure 5-5. Drain the melter by pumping as much hot melt material from the tank as possible using one of the following methods.

Method of Draining	Description
Gun	Place a suitable container under each gun nozzle. Remove each nozzle from its gun. Return the pump air pressure to its normal setting and pump the hot melt material out through the gun.
Manifold	Pump the hot melt material out through the manifold. Refer to <i>Flushing a Standard Manifold Filter</i> in this section.
Hose	Disconnect a hose from its gun. Replace the dust cover, which was removed during installation, over the hose electrical receptacle. Position the hose over a suitable waste container and secure it. Return the pump air pressure to its normal setting and pump the hot melt material out through the hose.

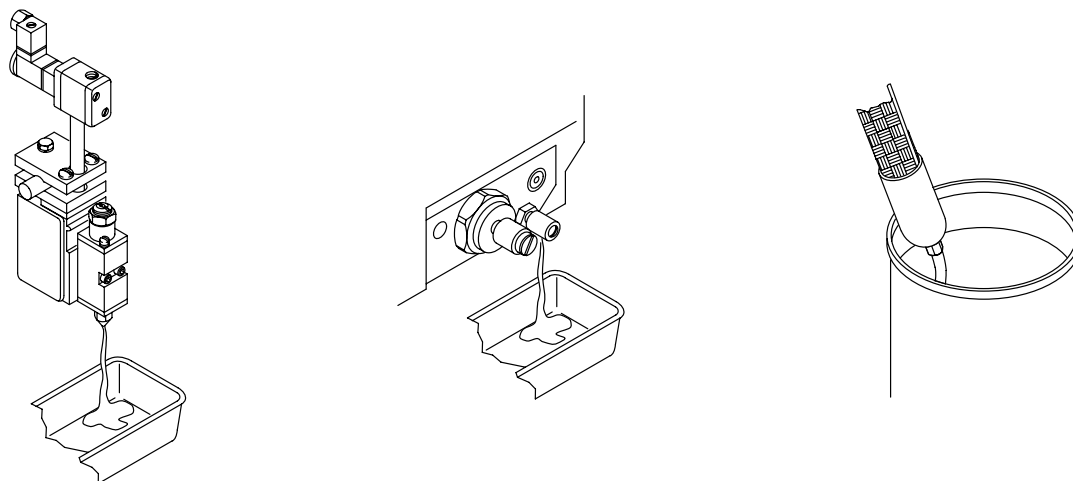

Figure 5-5 Methods of draining the melter

1. Draining through the gun

2. Draining through the manifold

3. Draining through the hose

4. If you have not already done so, disconnect each hose in the system from its gun.
5. Clean each automatic gun and handgun as needed. Refer to the gun manual for information on gun disassembly, cleaning, and rebuilding.

To Prepare for Flushing the System (contd)

6. Refer to Table 5-2 to determine which method of flushing the system is best for your operation.

Table 5-2 Advantages and Disadvantages of System Flushing Procedures

Flushing Procedure	Time Needed (See Note A)	Best Used for... (See Note B)	Advantages and Disadvantages
Using hot melt material	About 1 hour	Routine cleaning when the system is relatively free of char.	The advantage of this method is that it requires less downtime. However, it is not as thorough as the other two methods.
Using a flushing material recommended by your adhesive supplier and approved by your Nordson representative	From 2 ¹ / ₂ to 5 hours	Occasional cleaning when there is some char buildup.	Although this method requires more downtime, it does a good job of removing char buildup from the system. However, to remove all char you may need to scrub the tank. You will also need to purchase and store flushing material, which may have special storage and disposal requirements.
Using Type R fluid	From 3 to 13 hours	Thorough cleaning when there is significant char buildup.	This procedure is the most thorough way to remove char. You may also need to scrub the tank to remove all char. Disadvantages are that you cannot flush Type R fluid through the hoses; accidentally doing so can cause later downtime. Type R fluid is expensive but can be reused several times if the used fluid is strained into a storage container. The fluid is considered a regulated waste.

NOTE A: Time needed varies depending on how much char must be removed.

B: Because operating conditions vary from plant to plant, you may find that more or less frequent flushing is required.

7. Refer to the appropriate procedure for the flushing method you have selected:
 - *To Flush the System with Hot Melt Material*
 - *To Flush the System with a Flushing Material*
 - *To Flush the System with Type R Fluid*

To Flush the System with Hot Melt Material

1. Before beginning this procedure, first complete the procedure *To Prepare for Flushing the System* earlier in this section.

NOTE: This procedure describes how to flush all hoses at once. However, for maximum cleaning of badly charred hoses, use this procedure and flush each hose one at a time.

2. If you have not already done so, secure the free end of each hose to a container that will be used to collect the hot melt material.
3. Using a metal or plastic scoop, fill the tank to within 25 mm (1 in.) of the top with fresh, clean hot melt material.
4. Allow the melter to reach operating temperature.
5. Gradually increase pump air pressure by turning the air pressure regulator clockwise to pump hot melt material through the system until the material is free of char and contaminants.
6. Decrease pump air pressure to 0 by turning the valve fully counterclockwise.

CAUTION: Using a metal brush or scraper can damage Teflon-coated tanks. Use a stiff-bristled, nonmetal brush when cleaning a Teflon-coated tank.

7. Use a stiff-bristled, non-metal brush or similar tool to scrub the tank or dislodge as much char and debris as possible. Do not use a metal brush or scraper on Teflon-coated tanks.

NOTE: If this procedure does not remove all the charred material, you may need to replace the tank.

8. Clean the manifold filter. Refer to *Cleaning a Standard Manifold Filter* in this section.
9. Go to the procedure *To Restore the melter to Normal Operation* in this section.

To Flush the System with a Flushing Material



WARNING: Use the flushing material at the manufacturer's recommended temperature, which will be below the hot melt material's flash point. Failure to observe this warning can cause a fire.



WARNING: Never flush your system or clean any aluminum components with halogenated hydrocarbon cleaning solutions. These cleaning solutions are extremely dangerous when used to clean aluminum components in a pressurized fluid system.

CAUTION: Do not use this procedure to flush your system with Type R fluid. This procedure instructs you to pump flushing material through the hoses. Flushing Type R fluid through hoses can cause large pieces of char to break off and clog the nozzles during later operation. If you plan to use Type R fluid to flush your system, refer the procedure *To Flush the System with Type R Fluid* in this section.

CAUTION: Certain flushing materials can damage seals and O-rings, resulting in poor pump performance. Be sure that the flushing material you use has been approved by your Nordson representative. To determine the best flushing material to use, contact your adhesive supplier.

1. Before beginning this procedure, first complete the procedure *To Prepare for Flushing the System* earlier in this section.

NOTE: This procedure describes how to flush all hoses at once. However, for maximum cleaning of badly charred hoses, use this procedure and flush each hose one at a time.

2. If you have not already done so, secure the free end of each hose to a container that will be used to collect the hot melt material.
3. Set the tank and hose temperature to the recommended temperature of the flushing material. Refer to *Setting Up the Melter* in Section 3, *Installation*.

4. Pour the flushing material into the empty tank to within 25 mm (1 in.) of the top of the tank.
5. When the melter reaches the preset temperature, gradually increase pump air pressure by turning the air pressure regulator clockwise and pump material through the system until the flushing material starts to come out.
6. Decrease pump air pressure to 0 by turning the valve fully counterclockwise.
7. Allow the remaining material to drain from the hoses.
8. Remove the hoses from the collection container, place them over the tank, and secure them.
9. Slowly increase pump pressure by turning the air pressure regulator clockwise so the flushing material circulates through the system without splashing out of the tank. Allow the system to circulate for one and one-half to four hours.
10. Decrease pump air pressure to 0 by turning the air pressure regulator fully counterclockwise and wait for material to finish draining from the hoses.
11. Remove the hoses from the tank, secure them over a waste container and drain the flushing material from the tank into the container.

CAUTION: Using a metal brush or scraper can damage Teflon-coated tanks. Use a stiff-bristled, nonmetal brush when cleaning a Teflon-coated tank.

12. Use a stiff-bristled, nonmetal brush or similar tool to scrub the tank or dislodge as much char and debris as possible. Do not use a metal brush or scraper on Teflon-coated tanks.

NOTE: If this procedure does not remove all the charred material, you may need to replace the tank.

To Flush the System with a Flushing Material (contd)

13. Using a metal or plastic scoop, fill the tank to within 25 mm (1 in.) of the top with fresh, clean hot melt material.
14. Set the temperature of the tank to the lowest temperature that the adhesive can be pumped at. Refer to *Setting Up the Melter* in Section 3, *Installation*.
15. Wait for the melter to reach the preset temperature, then drain $\frac{3}{4}$ of the adhesive through the hoses into the waste container.
16. After you have drained $\frac{3}{4}$ of the material, reduce the pump air pressure to 0 by turning the air pressure regulator fully counterclockwise.
17. Place a container under the manifold drain valve, open the valve, and drain the remaining adhesive.
18. Clean the manifold filter. Refer to *Cleaning a Standard Manifold Filter* in this section.
19. Go to the procedure *To Restore the melter to Normal Operation* in this section.

To Flush the System with Type-R Fluid

1. Before beginning this procedure, first complete the procedure *To Prepare for Flushing the System* earlier in this section.
2. Set the tank temperature 14–17 °C (25–30 °F) higher than the recommended application temperature of the adhesive. Refer to *Setting Up the Melter* in Section 3, *Installation*.
3. Pour Type R fluid into the empty tank to within 25 mm (1 in.) of the top of the tank.
4. Use a clean paint brush or similar tool to apply fluid to areas not submerged in the fluid.
5. Allow the fluid to heat in the tank for 2–12 hours.
6. As needed, use a wooden or plastic strainer to skim off the char and adhesive that floats to the top of the tank.

CAUTION: Do not pump Type R fluid through hoses. Fluid absorbed by char in the hoses may leach out or cause large pieces of char to break off and clog a nozzle during later operation.

7. Place a container under the manifold drain valve, open the valve, and drain the fluid from the manifold.

NOTE: You can reuse the fluid if you place a strainer on the top of the container used to collect it.

8. Close the manifold drain valve.
9. Using a metal or plastic scoop, place several pounds of fresh, clean hot melt material into the empty tank.
10. Set the temperature of the tank and hoses to the lowest temperature that the adhesive can be pumped at. Refer to *Setting Up the Melter* in Section 3, *Installation*.
11. Secure the free end of the hose to a container that will be used to collect the hot melt material.
12. When the tank and hoses reach their setpoint temperatures, gradually increase pump pressure by turning the air pressure regulator clockwise to pump adhesive through the hoses.
13. Continue pumping adhesive into the waste container until a clean, steady stream of material flows from each hose.
14. When material has finished draining, reduce the pump air pressure to 0 by turning the valve fully counterclockwise.
15. Clean the manifold filter. Refer to *Cleaning a Standard Manifold Filter* in this section.
16. Go to the procedure *To Restore the melter to Normal Operation* in this section.

To Restore the melter to Normal Operation

After flushing your system with hot melt material, a flushing material, or Type R fluid, follow this procedure to restore your melter to normal operation.

1. Disconnect and lock out electrical power to the melter.
2. Reconnect each gun to its hose both electrically and mechanically. Refer to *Connecting Hoses and Guns* in Section 3, *Installation*.
3. Remove the lock-out and restore power to the melter.
4. If you have changed the melter's temperature setpoints or if the recommended operating temperature of the new adhesive is different from the previous adhesive, reprogram the temperature settings. Refer to *Setting Up the Melter* in Section 3, *Installation*.
5. Use a metal or plastic scoop to fill the tank with adhesive. Refer to *Filling the Tank* in Section 4, *Operation*.
6. Return the air supply pressure to the normal operating setting.
7. Resume normal operation.

Cleaning the Melter

To prevent components from overheating due to heat build-up or loss of air circulation, regularly remove any hot melt that collects on the exterior of the melter, hoses, and guns.

If hot melt inadvertently spills inside the melter's interior spaces, the side panels can be removed in order to clean out the spilled hot melt.



WARNING: Risk of electrocution and fire! Do not clean the melter with a direct stream of water or steam. Use only water or an appropriate, non-flammable cleaning solution that is applied using a clean cloth. Cleaning the melter using a direct stream of water or steam or a flammable solvent can result in property damage and personal injury, including death.

To clean the exterior of the melter

- Apply cleaning compounds using a soft cloth.
- Do not use pointed or sharp tools to clean the exterior surface.

Cleaning the Tank

To avoid the problems that can occur when different hot melt materials are mixed or when hot melt char forms in the tank, clean the tank when:

- changing to a different type of hot melt
- excessive char builds up inside the tank

NOTE: The tank cleaning procedures provided in this section require that an appropriate flushing material be used. The flushing material should be compatible with both the previous adhesive and the new adhesive, if applicable.

To clean the tank when changing hot melt

1. Operate the melter normally until the tank is empty.
2. Close the air supply to the melter.
3. Allow the melter to heat or cool to the temperature recommended by the manufacturer of the flushing material.
4. While wearing the appropriate protective equipment, wipe any residual hot melt from the inside of the tank.
5. Add the appropriate type and quantity of flushing material to the tank.
6. Open the air supply to the melter.
7. Pump all of the flushing material from the tank and through the hoses and guns.
8. Return the melter to normal operation and pump a minimum of one tank volume of fresh hot melt through the tank, hoses, and guns.

To clean the tank of excessive char

1. Remove the old hot melt and loose char as follows:
 - a. Operate the melter normally until the tank is empty.
 - b. Close the air supply to the melter.
 - c. Allow the melter to heat or cool to the temperature recommended by the manufacturer of the flushing material.
 - d. While wearing the appropriate protective equipment, wipe any residual hot melt and loose char from the inside of the tank.
 - e. Remove the tank strainer, clean it with an appropriate flushing material, and then reinstall it.
2. Add the appropriate type and quantity of hot melt solvent to the tank.
3. Disconnect a hose from a gun and direct the hose into a waste container.
4. Close the pressure control valve by turning the valve all the way clockwise.



WARNING: Risk of burns! Wear protective equipment and use caution when pumping hot material into a waste container.

5. Open the air supply to the melter.
6. When the tank is empty, close the air supply to the melter.
7. Fill the tank with fresh hot melt.
8. Repeat steps 5 and 6 to pump all of the hot melt out of the tank.
9. Reconnect the disconnected hose to its gun.
10. Clean the filter. Refer to *Cleaning a Standard Manifold Filter* in this section.
11. Fill the tank with fresh hot melt and then purge all of the hoses and guns with the fresh hot melt.
12. Restore the system to normal operation.

Flush the System

Before operating your melter for the first time, flush the system by pumping adhesive through it to remove trapped air and residue left during factory testing.

1. Use one of the following methods to prevent accidental gun triggering:
 - Air-operated guns: turn off the operating air.
 - Electric guns: turn off the gun driver.
 - Hand-operated guns: lock the trigger.



WARNING: Hot! Risk of burns. Wear heat-protective clothing, safety goggles, and heat-protective gloves.

2. Place a drain pan under each gun and remove all gun nozzles.
3. Reduce the pump air pressure to 0 by turning the air pressure regulator fully counterclockwise.
4. If the melter is not already on, press the power switch to turn the melter on. Allow the melter to reach operating temperature.
5. Clean the manifold filter. Refer to *Cleaning a Standard Manifold Filter* in this section.
6. Prepare each gun in your system for operation as follows:
 - Air-operated guns: increase the operating air pressure to 2.4 bar (240 kPa, 35 psi).
 - Electric guns: turn on the gun driver.
 - Hand-operated guns: unlock the trigger.



WARNING: Trapped air may still be in the hoses and guns. Shield the area and operator from splashing adhesive.

7. Trigger the guns, keeping them open so that no pressure builds up.

NOTE: You may need to adjust the gun air pressure depending on the viscosity of the adhesive and the gun response.

8. Gradually increase the air pressure to the pump by turning the air pressure regulator clockwise. Allow adhesive to flow out of the guns until all trapped air, cleaning solution, and impurities are flushed out of the system. If the pump slows noticeably or stops, increase pump air pressure slightly.
9. Stop triggering the guns.
10. Reduce pump air pressure to 0 by turning the air pressure regulator fully counterclockwise.
11. Trigger the guns momentarily to relieve trapped hydraulic pressure.
12. Attach the nozzles to the guns.
13. Adjust the pump air pressure regulator until the air pressure is at the desired operating setting. Test adhesive patterns as necessary.
14. *Air-operated guns only:* adjust the gun air pressure regulator until the air pressure is at the desired operating setting. Test adhesive patterns as necessary.
15. Refer to the gun product manual for additional setup information for the specific gun.

This page intentionally left blank.

Section 6

Troubleshooting



WARNING: Allow only personnel with appropriate training and experience to operate or service the equipment. The use of untrained or inexperienced personnel to operate or service the equipment can result in injury, including death, to themselves and others, and damage to the equipment.

This section provides quick-reference information for diagnosing melter faults indications as well as comprehensive melter diagnostic information that is provided in flowchart format.

If you cannot resolve the problem using the troubleshooting flowchart, contact your Nordson representative for technical assistance.

400/480 Volt Melters

Refer to Appendix C, *400/480 Volt Mesa Adhesive Melters*, for information about troubleshooting the transformer base, for 400/480 volt heater information, and for information about parts that are specific to 400/480 volt melters.

NOTE: With the exception of power supply and heater failure problems, the information provided in this section applies to all Mesa melters.

Safety

- Never disconnect cables from, or reconnect cables to, any circuit board while the melter is energized.
- Before breaking any hydraulic connection, always relieve system pressure. Refer to *Relieving System Pressure* in Section 5, *Maintenance*.
- Refer to the safety information provided with optional equipment.

Melter Faults

Table 6-1 lists the four types of melter faults, potential causes, and expected corrective actions.

Table 6-1 Melter Faults

Display Code/Sub-code	Name	Affect on Melter	Cause	Corrective Action
F1/None	RTD	Heaters turn off	The RTD for the component indicated has failed or the component was disconnected from the melter.	Replace RTD Check hose/gun connections See flowchart T.2
F2/None	Under temperature	Heaters turn off	The actual temperature of the component indicated has dropped below the under temperature delta, which was set using parameter 22.	Check for conditions that may cause a drop in ambient temperature Replace RTD See flowchart T.2
F3/None	Over temperature	Heaters turn off	The actual temperature of the component indicated has increased beyond the over temperature delta, which was set using parameter 21.	Replace RTD See flowchart T.2
F4/1	RAM test	Melter stops functioning	Internal RAM failure	Replace CPU
F4/2	Internal Clock time	Heaters remain on, but fault condition persists	Internal clock failure	Replace CPU
F4/3	RAM backup battery	Clock does not function	Insufficient voltage from RAM backup battery	Replace CPU
F4/4	Internal clock battery backed RAM	Heaters remain on, but fault condition persists	Battery-backed RAM failure	Replace CPU
F4/5	Internal clock battery	Heaters remain on, but fault condition persists	Battery-backed RAM battery dead	Replace CPU
<i>Continued...</i>				

Table 6-1 Melter Faults (contd)

Display Code/Sub-code	Name	Affect on Melter	Cause	Corrective Action
F4/6	Analog-to-digital	Melter stops functioning	RTD analog-to-digital converter failed	Replace main board or CPU
F4/7	Analog-to-digital calibration	Melter stops functioning	Failed hose or gun RTD analog-to-digital converter could not be calibrated (grounded RTD in system)	Replace hose or gun. Note: Set setpoint to zero to avoid F1 fault. Replace main board, ribbon cable, or CPU.
F4/8	Main board feedback	Melter stops functioning	Communication failure between main board and CPU	Replace main board, ribbon cable, or CPU
F4/A	Thermostat	Melter stops functioning	Tank or manifold thermostat is open	Replace thermostat, J7 harness, or main board
F4/C	Expansion board connection	Melter stops functioning	Ribbon cable P/N 1026662 is not connected at J1 on the main board and/or at J2 on the expansion board	Check the ribbon cable connections and make connections as applicable.
F4/d	Communications with optional I/O card	Heaters remain on, but fault condition persists	Communication failure between CPU and the optional I/O card	Replace the I/O card or CPU

Using the Troubleshooting Flow Chart

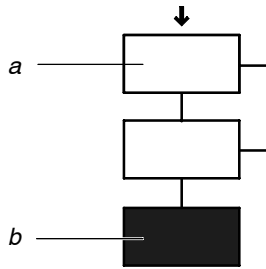

Troubleshooting question and action blocks

a) Question b) Action

The flowchart, which is provided at the end of this section, is designed to assist you in diagnosing and correcting a complete or partial stop in hot melt output from the guns. The chart is organized in a simple question-action block format. If your response to a question is yes (+), continue downward in the chart to the next question or action block. If your response is no (-), continue to the right to the next question or action block. All diagnostic paths within the chart end with an action block that specifies one of the following three courses of action:

- Refer to information provided elsewhere in this manual
- Replace a component

To return your melter to service as quickly as possible, the chart is designed under the assumption that it is preferable to immediately replace a faulty assembly as opposed to conducting detailed diagnostics and repair of the assembly while the melter is out of service.

Use of the chart assumes that the melter is installed correctly and that it is set up to support the current manufacturing process. Refer to Section 3, *Installation*, for information about installing and setting up the melter.

Troubleshooting Quick-checks

Before using the troubleshooting charts confirm:

- whether or not service was recently performed on the melter or the melter's settings were recently adjusted.
- the correct voltage plugs are installed on the input power/tank board and the expansion board. Refer to Section 3, *Installation*, for information about selecting the correct voltage plugs.
- external inputs (if used) are functioning properly.
- the standby or clock functions are not turned on (if not required or expected at the current time).

Returning the Melter Setup to Factory Settings

By returning the melter to its factory setting many common melter problems can be isolated to either a problem with the melter settings or the melter hardware.

To return the melter to its factory settings, simultaneously press and hold the Setup key and the right-display DOWN arrow key, and then, while holding down these keys, cycle the melter control switch off and on. When the melter restarts, release the two keys.

Identifying Electrical Components

Tables 6-2 through 6-5 provide detailed descriptions of the circuit board indicators, connection points, and test points that are referred to in the troubleshooting chart. Figure 6-1 illustrates the location of each of these circuit board components.

Table 6-2 Main Board Components

Item Number	Type	Description
<i>Indicators</i>		
DS4	Neon	Power into board
DS5	Neon	Power to hose/gun 1 heaters
DS6	Neon	Power to hose/gun 2 heaters
DS8	LED (yellow)	Control signal for hose 1
DS9	LED (yellow)	Control signal for gun 1
DS10	LED (yellow)	Control signal for tank heater
DS12	LED (yellow)	Control signal for gun 2
DS13	LED (yellow)	Control signal for hose 2
DS15	LED (green)	+5 VDC out of low-voltage power supply
<i>Fuses</i>		
F3/F4	--	Main power to board (2A, 250 V, slow-blow)
F7/F8	--	Hose/gun 1 heaters (6.3 A, 250 V, 5 x 20 mm)
F9/F10	--	Hose/gun 2 heaters (6.3 A, 250 V, 5 x 20 mm)
<i>Continued...</i>		

Identifying Electrical Components *(contd)*

Table 6-2 Main Board Components *(contd)*

Item Number	Type	Description
<i>Connection Points</i>		
XT1	Input	High-voltage power connection to board
J1	Input/output	Signal ribbon cable between main board and CPU
XP6	Output	Control voltage to tank RTD
X4	Input/output	High-voltage and control voltage out to hose/gun 1
X5	Input/output	High-voltage and control voltage out to hose/gun 2
X7	Input	Switch closure from melter control switch
<i>Test Points</i>		
TP7	Contact	+5 VDC out of low-voltage power supply
TP2	Contact	Circuit common of low-voltage power supply
JP1	Configuration header	Shunt jumper must be present for correct Mesa software operation

Table 6-3 Expansion Board Components

Item Number	Type	Description
<i>Indicators</i>		
DS1	LED	24 VDC present at X3
<i>Connection Points</i>		
XT1	Input	AC power into board
XT2	Output	AC power out to power module (Hose/Guns 3 and 4)
XT3	Output	AC power out to main board
XT7	Output/Input	Positions 1–6 are control outputs; Positions 7–14 are control inputs
X1/X2	Jumper	Input voltage configuration plugs
X3	Input	24 VDC in from main board
X4	Input/output	Ribbon cable connection between expansion board and power module (Hose/gun 3 and 4)
X5	Input/output	Ribbon cable connection between expansion board and power module (Hose/gun 5 and 6)
J2	Input/output	Ribbon cable connection between expansion board and main board
XT6	Output	Switched 24V DC to pump solenoid
XT5	Output	Relay and SSR control for 480V melters
J4	Output	High voltage to tank heater
XT8	Output	AC power to auxillary control

Table 6-4 Power Module Components (Hoses/Guns 3/4)

Item Number	Type	Description
<i>Indicators</i>		
N1	Neon	Hose 4 is turned on
N2	Neon	Gun 4 is turned on
N3	Neon	Hose 3 is turned on
N4	Neon	Gun 3 is turned on
<i>Connection Points</i>		
J1	Input/output	Ribbon cable connection between power module and expansion board
J2	Input/output	Connection point for the wire harness between hose/gun 4 and the power module
J3	Input/output	Connection point for the wire harness between hose/gun 3 and the power module
J4/J5	Input	AC power input from XT2 on the expansion board
<i>Fuses</i>		
F1, F2	--	Hose 4 and gun 4
F3, F4	--	Hose 3 and gun 3

Table 6-5 Power Module Components (Hoses/Guns 5/6)

Item Number	Type	Description
<i>Indicators</i>		
N1	Neon	Hose 6 is turned on
N2	Neon	Gun 6 is turned on
N3	Neon	Hose 5 is turned on
N4	Neon	Gun 5 is turned on
<i>Connection Points</i>		
J1	Input/output	Ribbon cable connection between power module and expansion board
J2	Input/output	Connection point for the wire harness between hose/gun 6 and the power module
J3	Input/output	Connection point for the wire harness between hose/gun 5 and the power module
J4/J5	Input	AC power input from XT2 on the expansion board
<i>Fuses</i>		
F1, F2	--	Hose 6 and gun 6
F3, F4	--	Hose 5 and gun 5

Identifying Electrical Components *(contd)*

Table 6-6 Input Power/Tank Board Components

Item Number	Type	Description
<i>Connection Points</i>		
XT1	Input	Main AC power input from customer
XT2	Output	AC power to expansion board
XT3	Output	AC power to tank solid-state relay and heater
XT4	Input	Relay control signal
X1/X3	Jumper	Input voltage configuration plugs
<i>Fuses</i>		
F1, F2	--	Tank heater

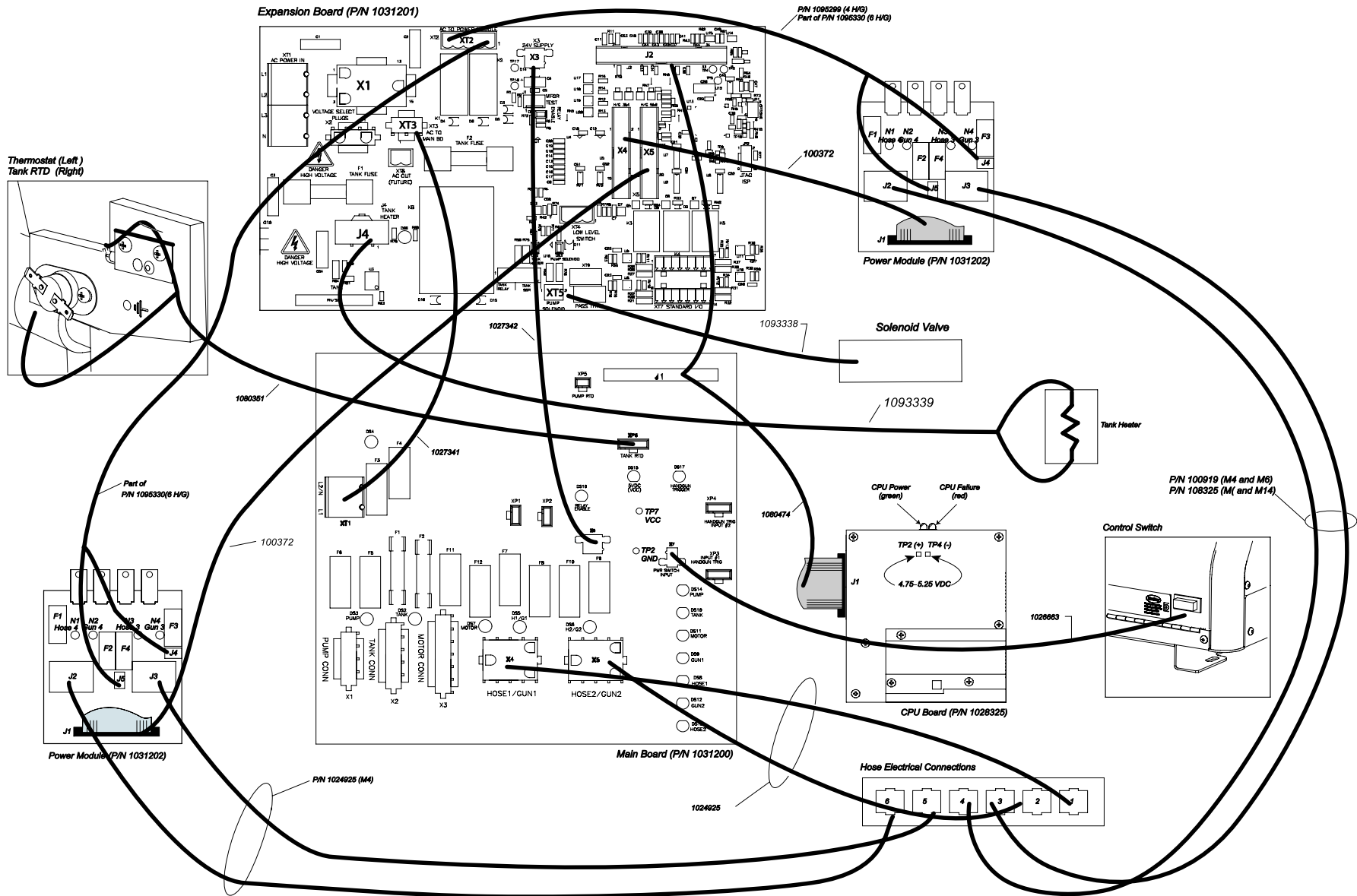

Figure 6-1 Location of electrical components and cables

This page intentionally left blank.

No adhesive output from one or more guns

Mesa Troubleshooting Charts

<< Start

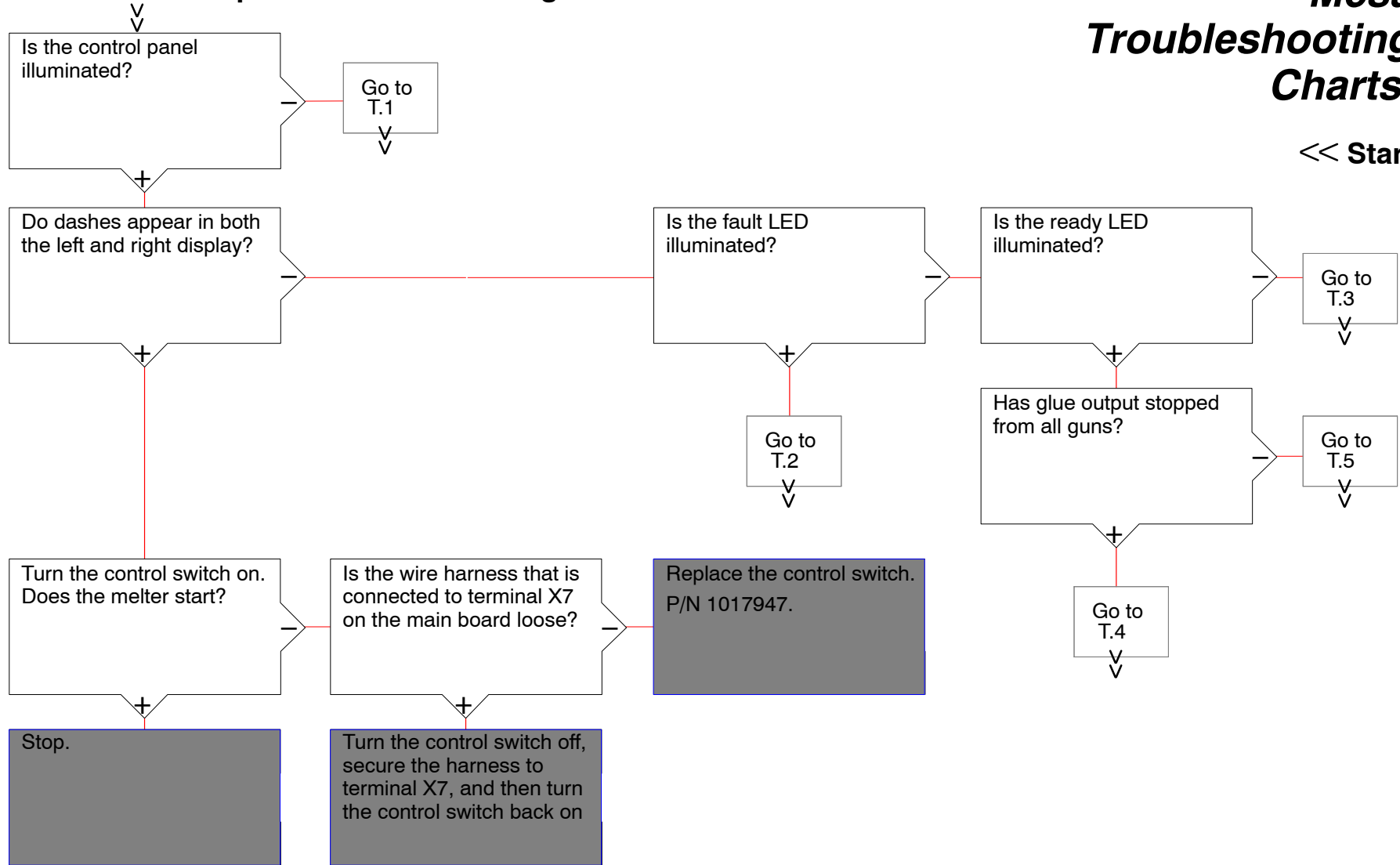

This page intentionally left blank.

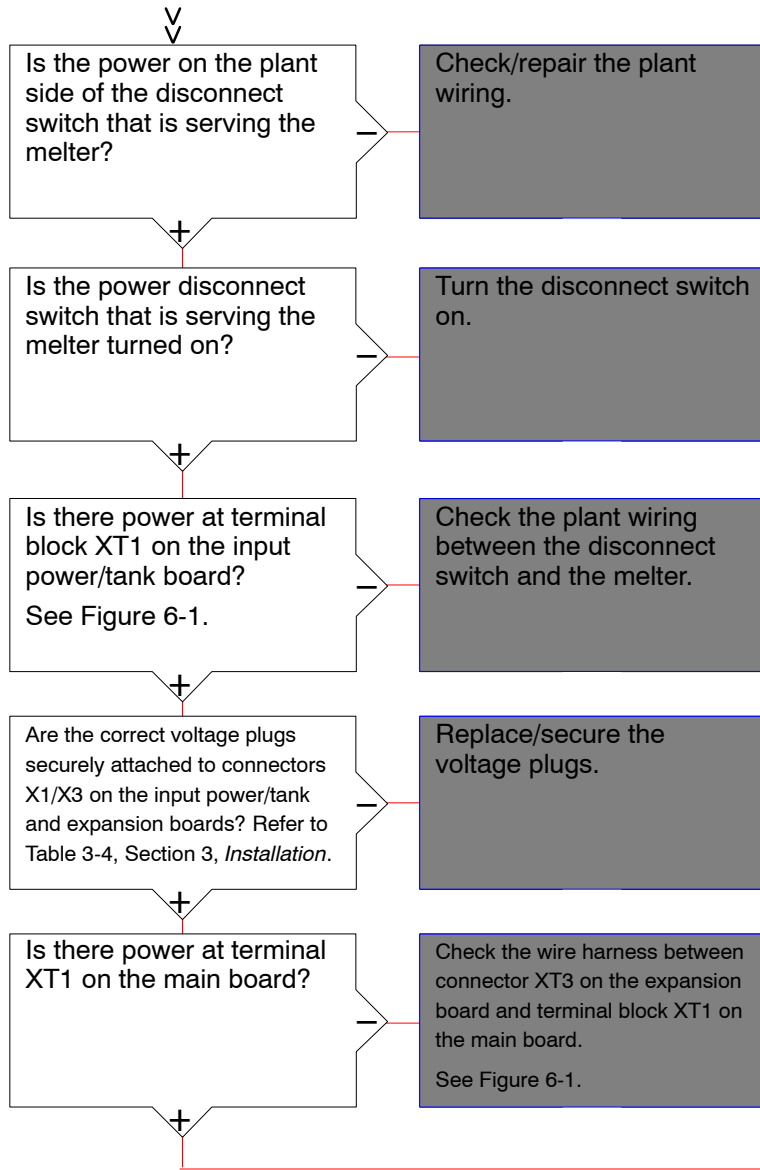

T.1

Control panel is not illuminated

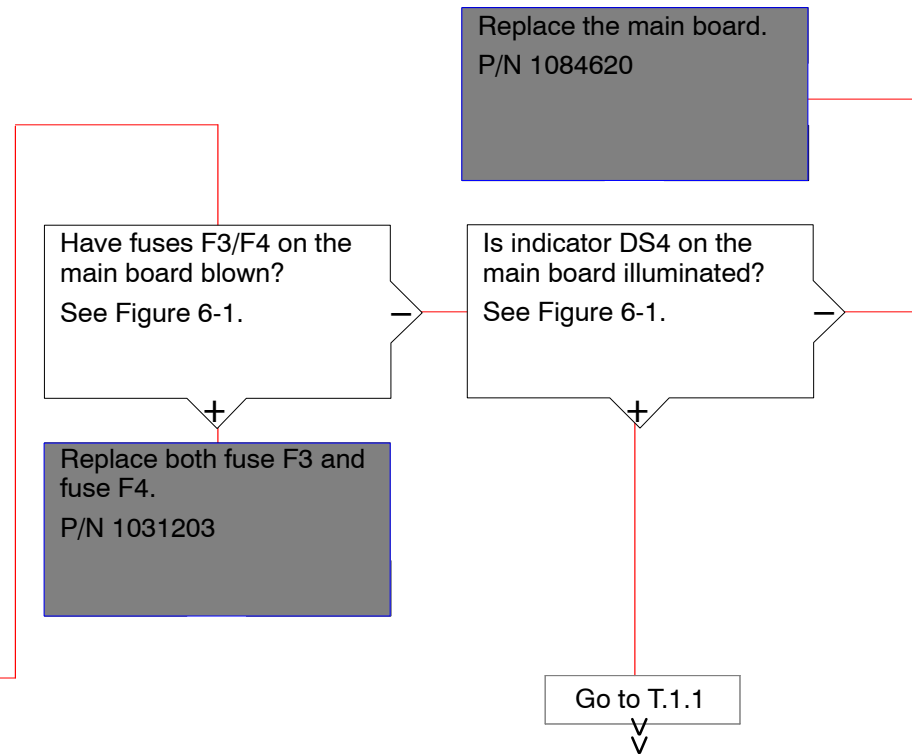

This page intentionally left blank.

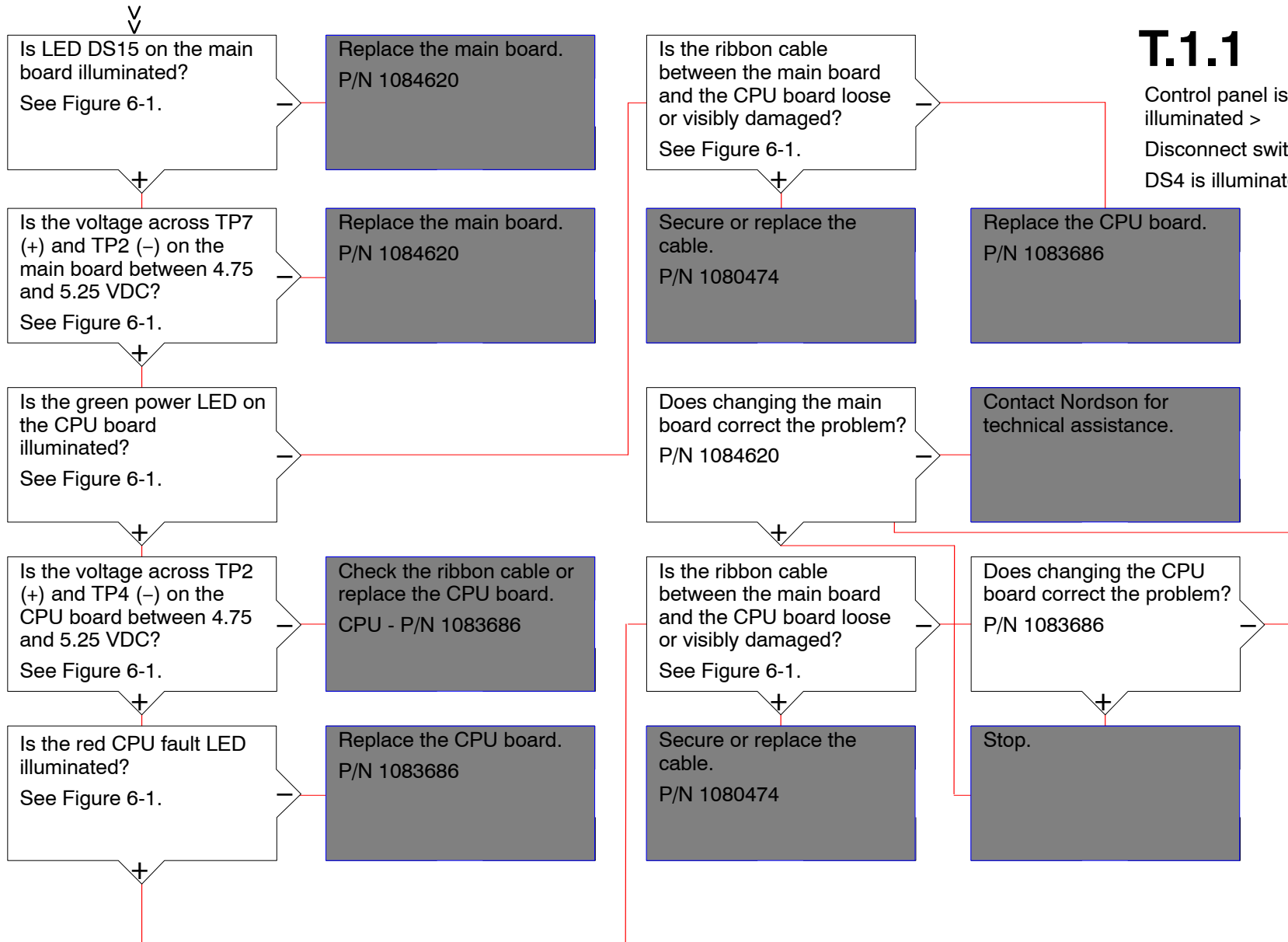

T.1.1

Control panel is not illuminated >
Disconnect switch is on >
DS4 is illuminated

This page intentionally left blank.

T.2

Fault LED is illuminated

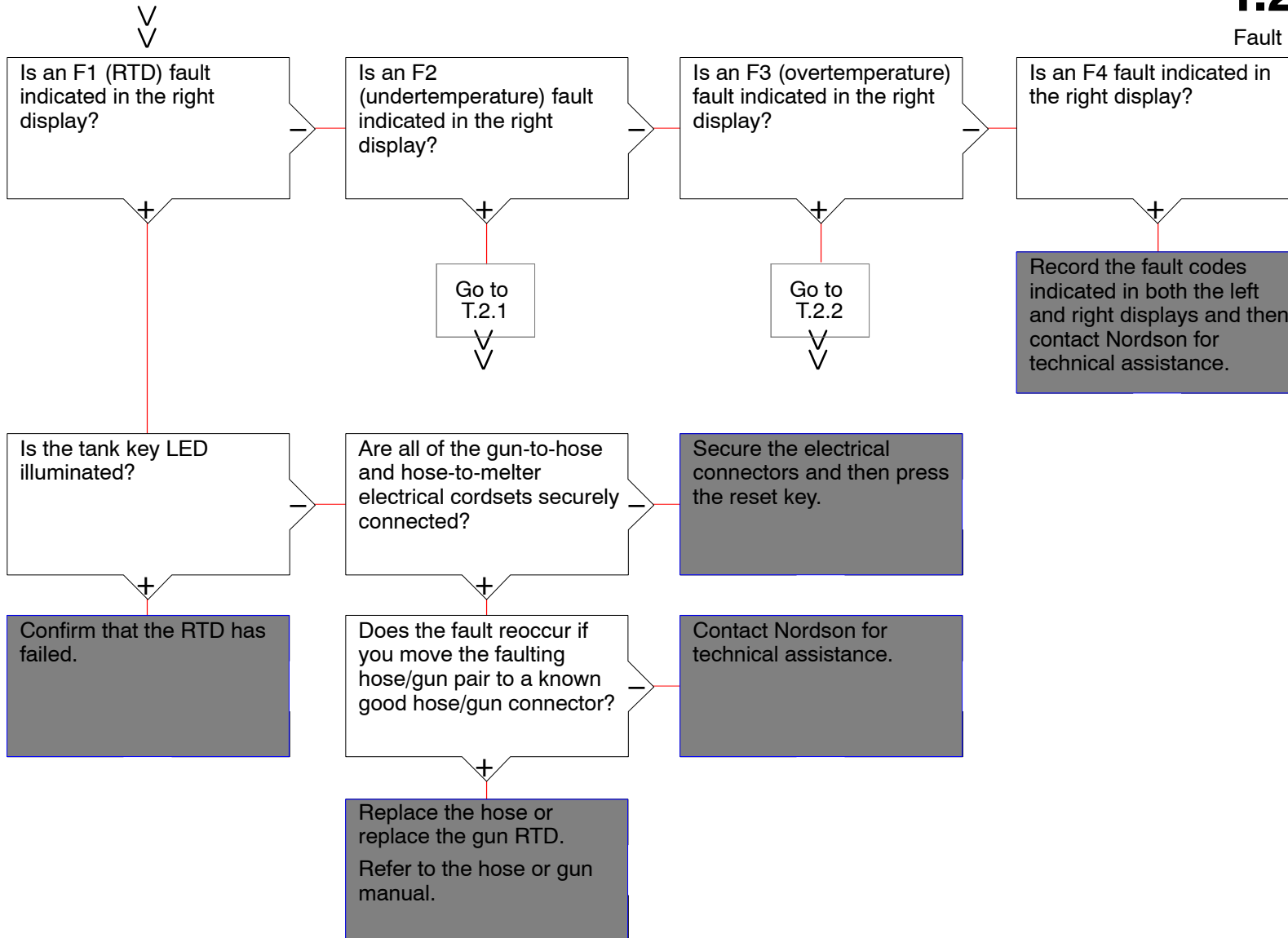

This page intentionally left blank.

Reset the melter and turn the heaters back on

T.2.1

Fault LED is illuminated >
F2 fault exists

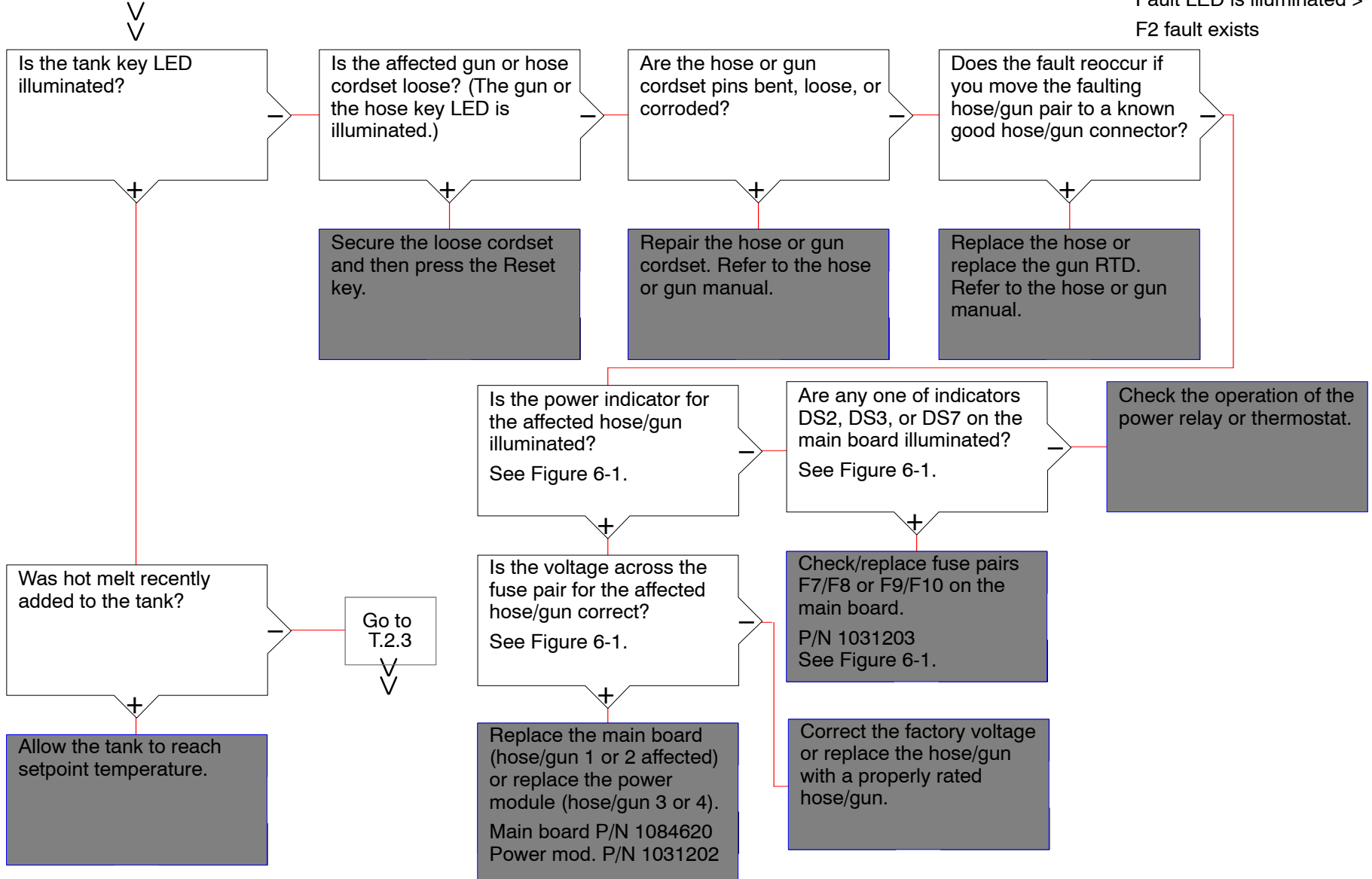

This page intentionally left blank.

Reset the melter and turn the heaters back on

T.2.2

Fault LED is illuminated >
F3 fault exists

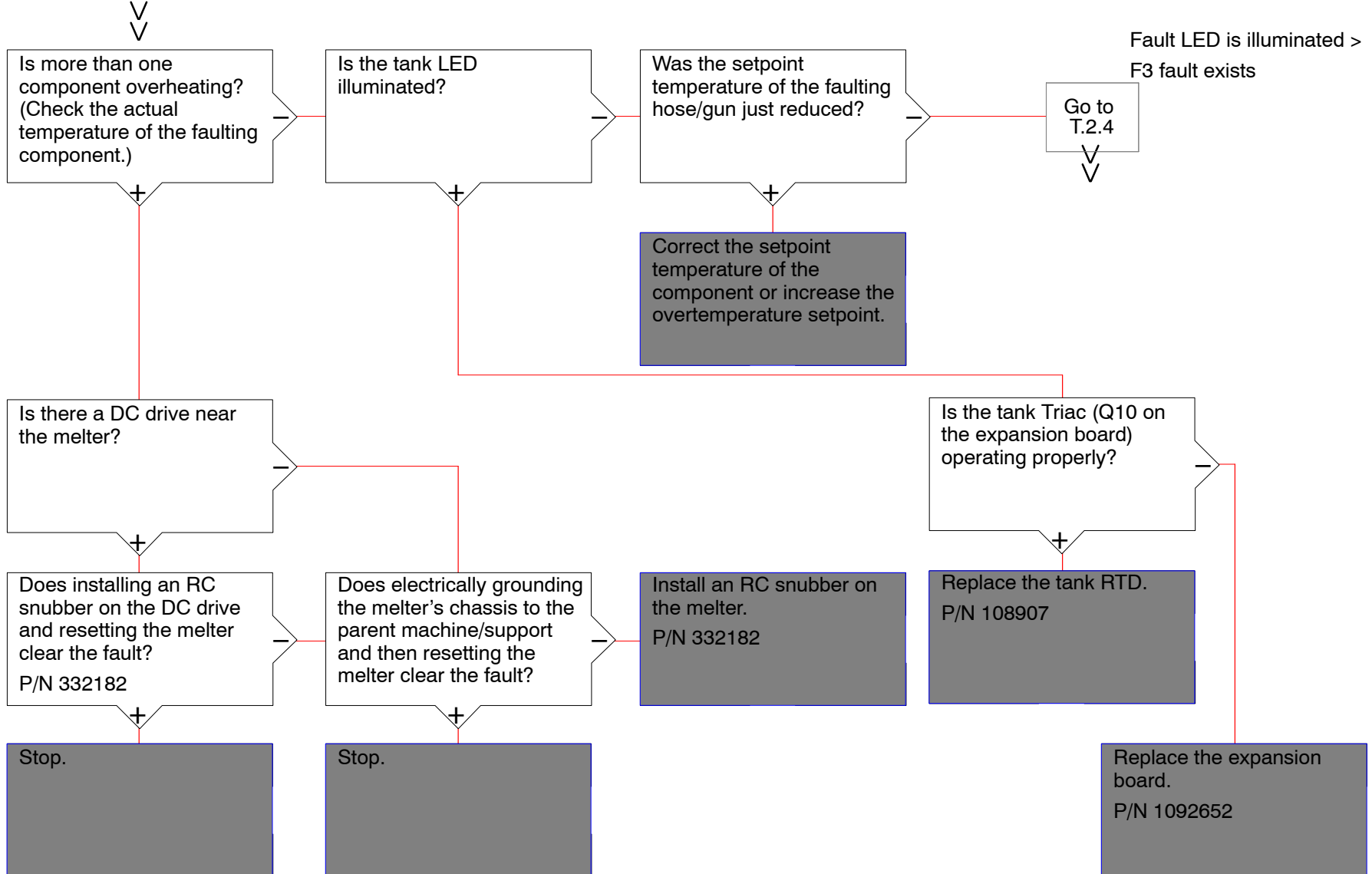

This page intentionally left blank.

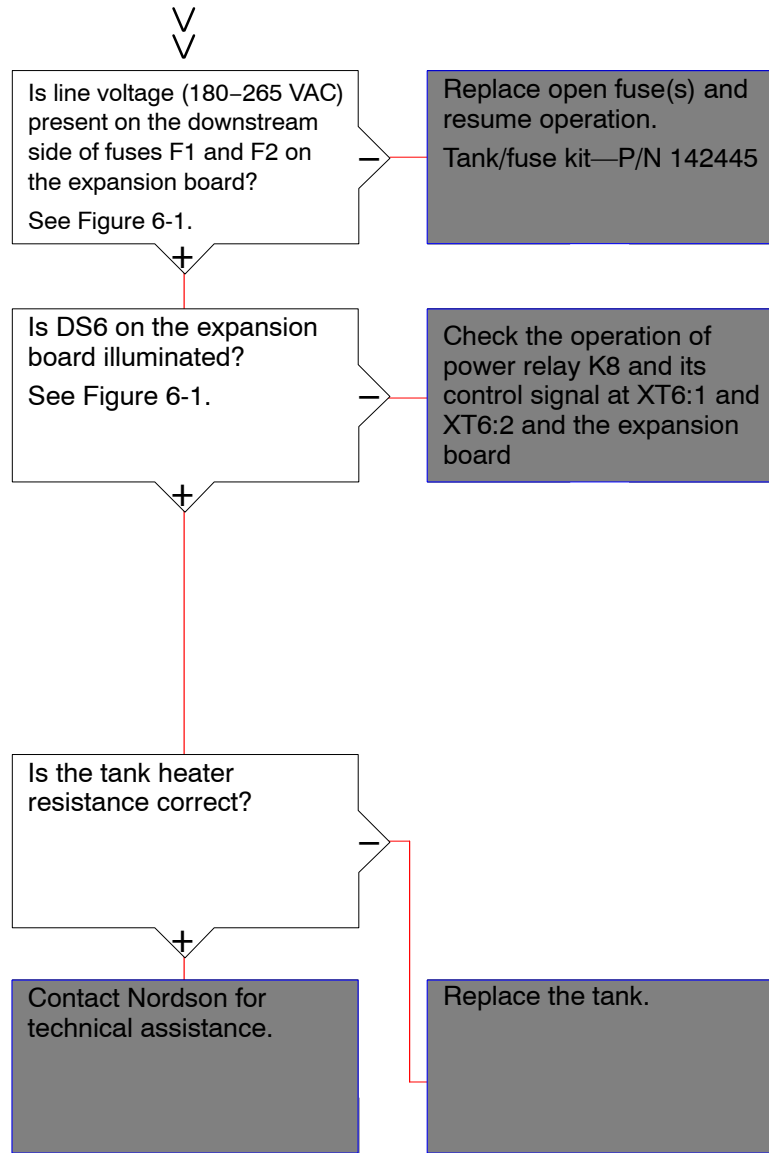

T.2.3

Fault LED is illuminated >

F2 fault exists >

Tank key LED is illuminated >

No hot melt was recently added to the tank

This page intentionally left blank.

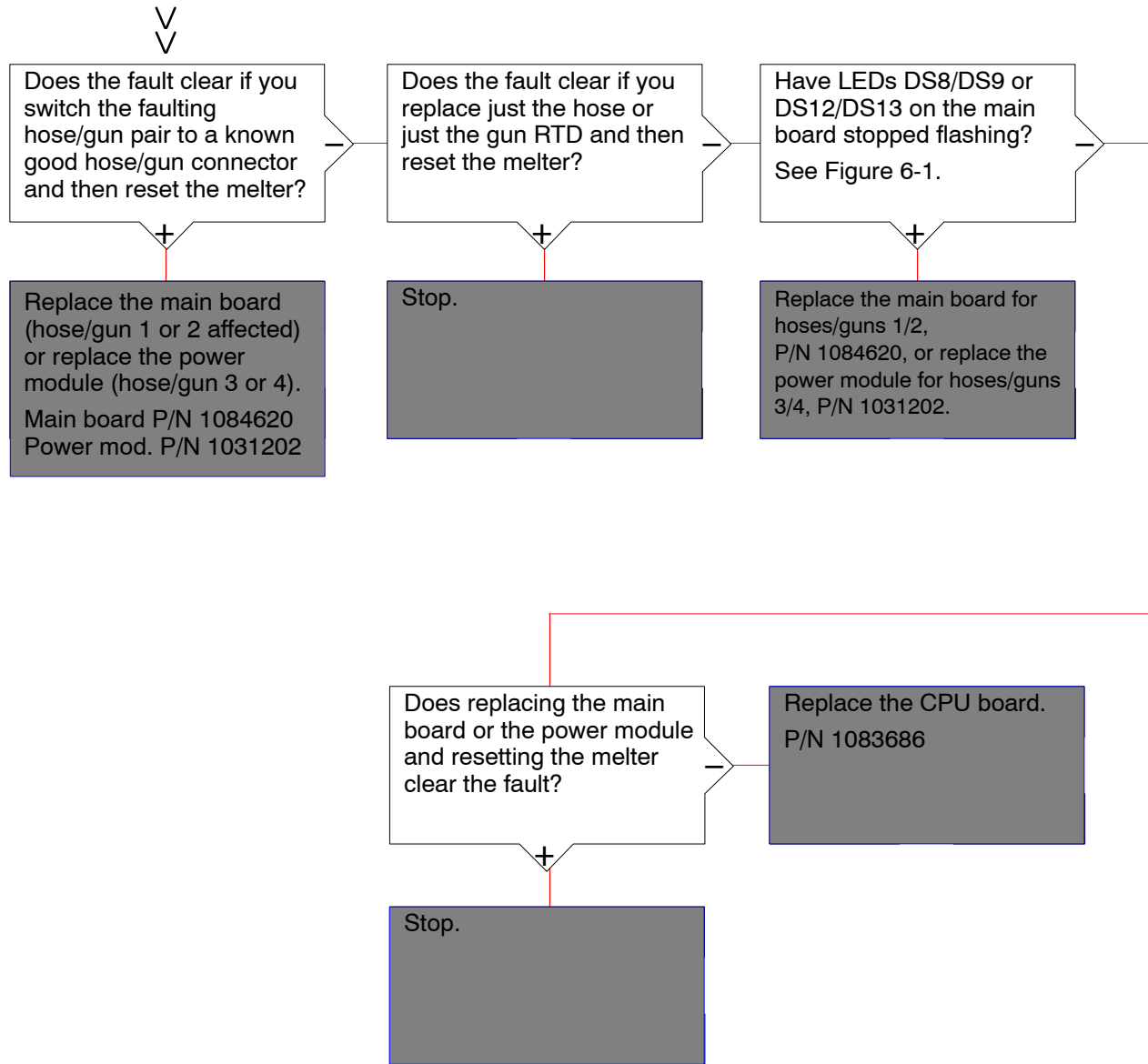

T.2.4

Fault LED is illuminated >
An F3 fault exists on a hose or gun >
The setpoint temperature was not changed

This page intentionally left blank.

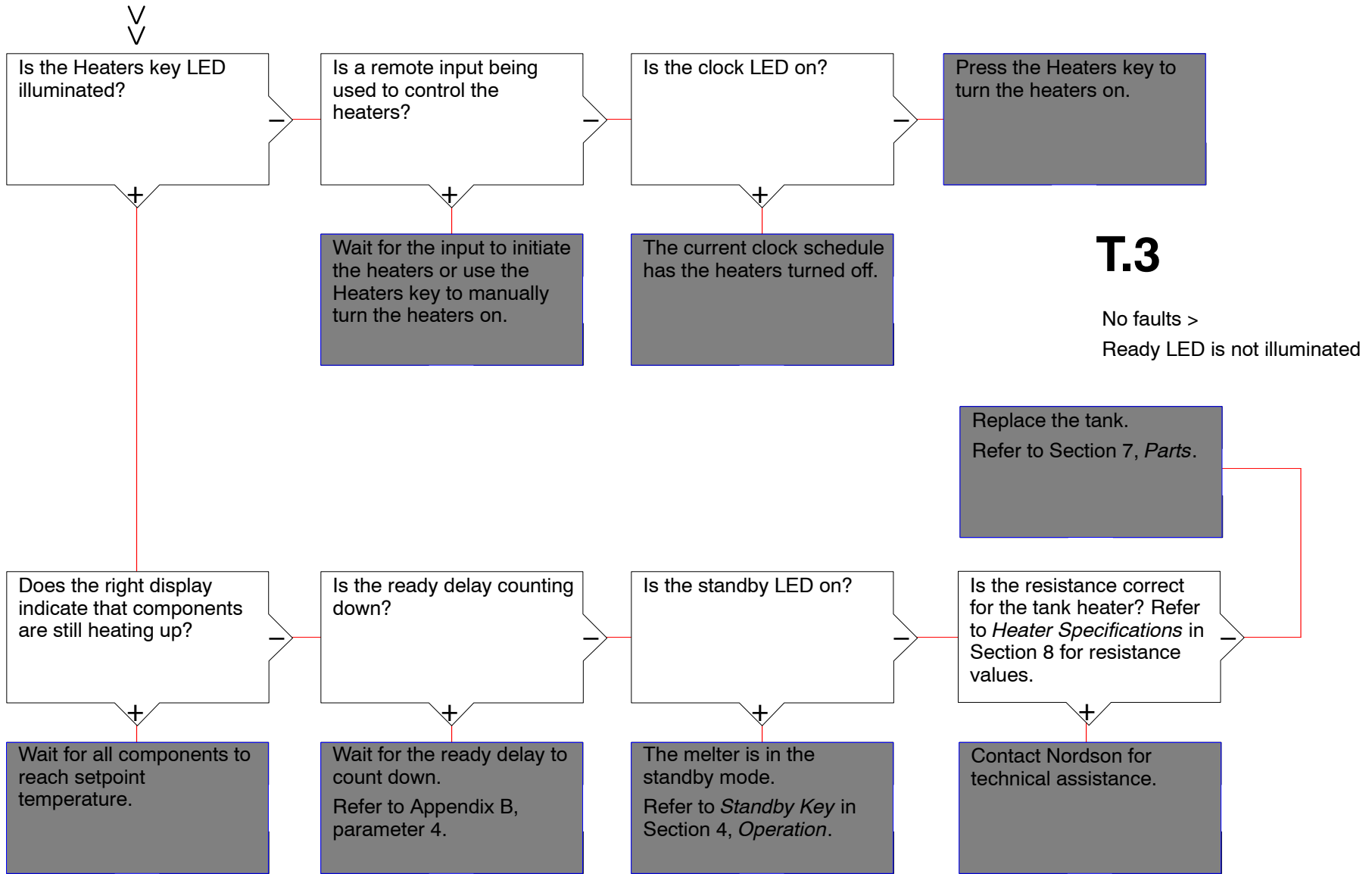

This page intentionally left blank.

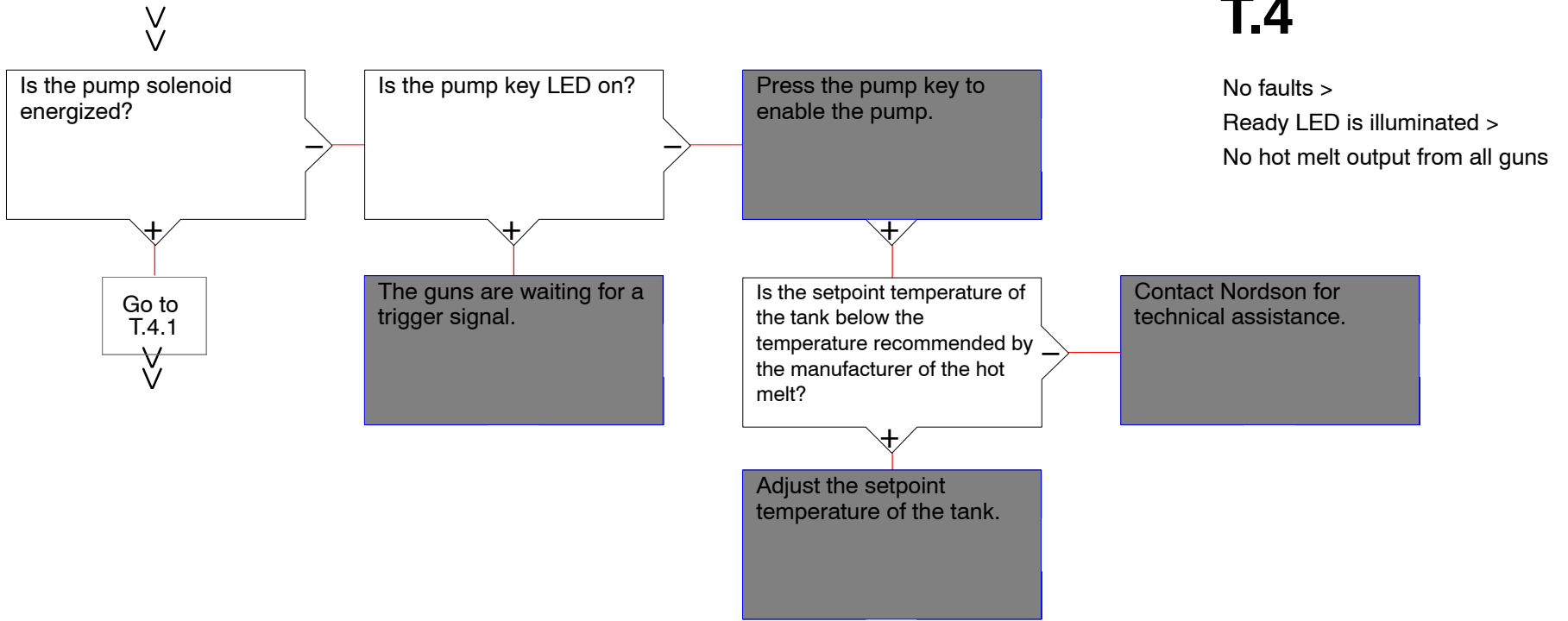

T.4

No faults >
Ready LED is illuminated >
No hot melt output from all guns

This page intentionally left blank.

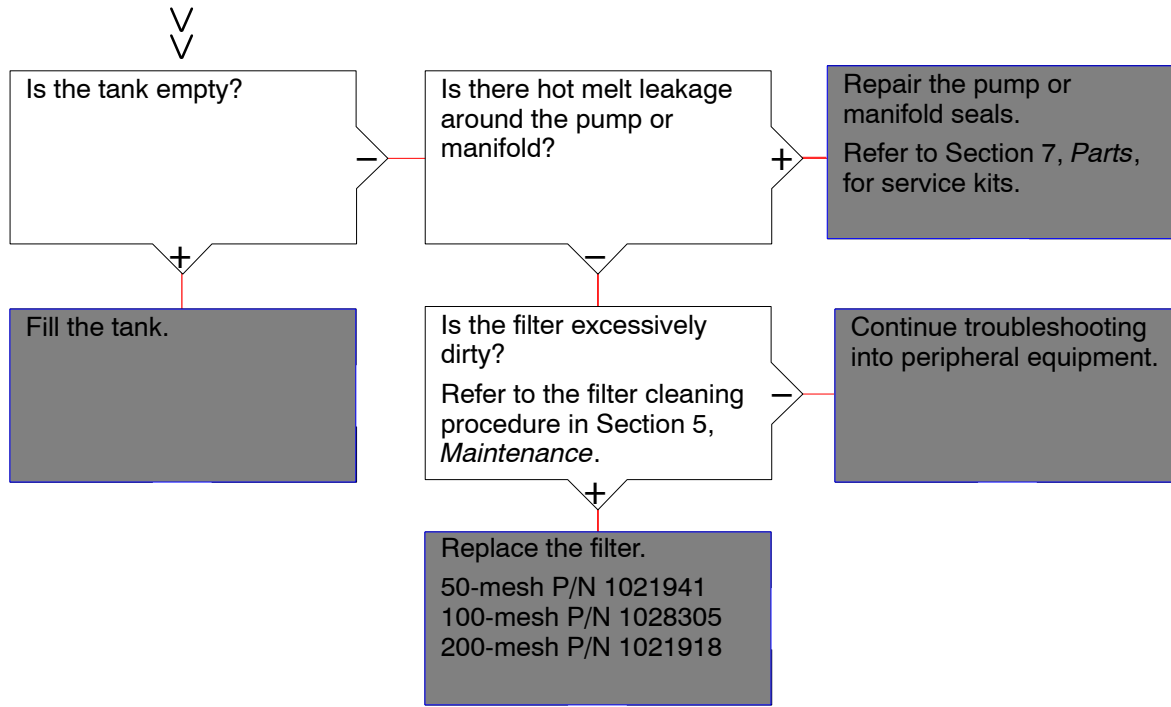

T.4.1

- No faults >
- Ready LED is illuminated >
- No hot melt output from all guns

This page intentionally left blank.

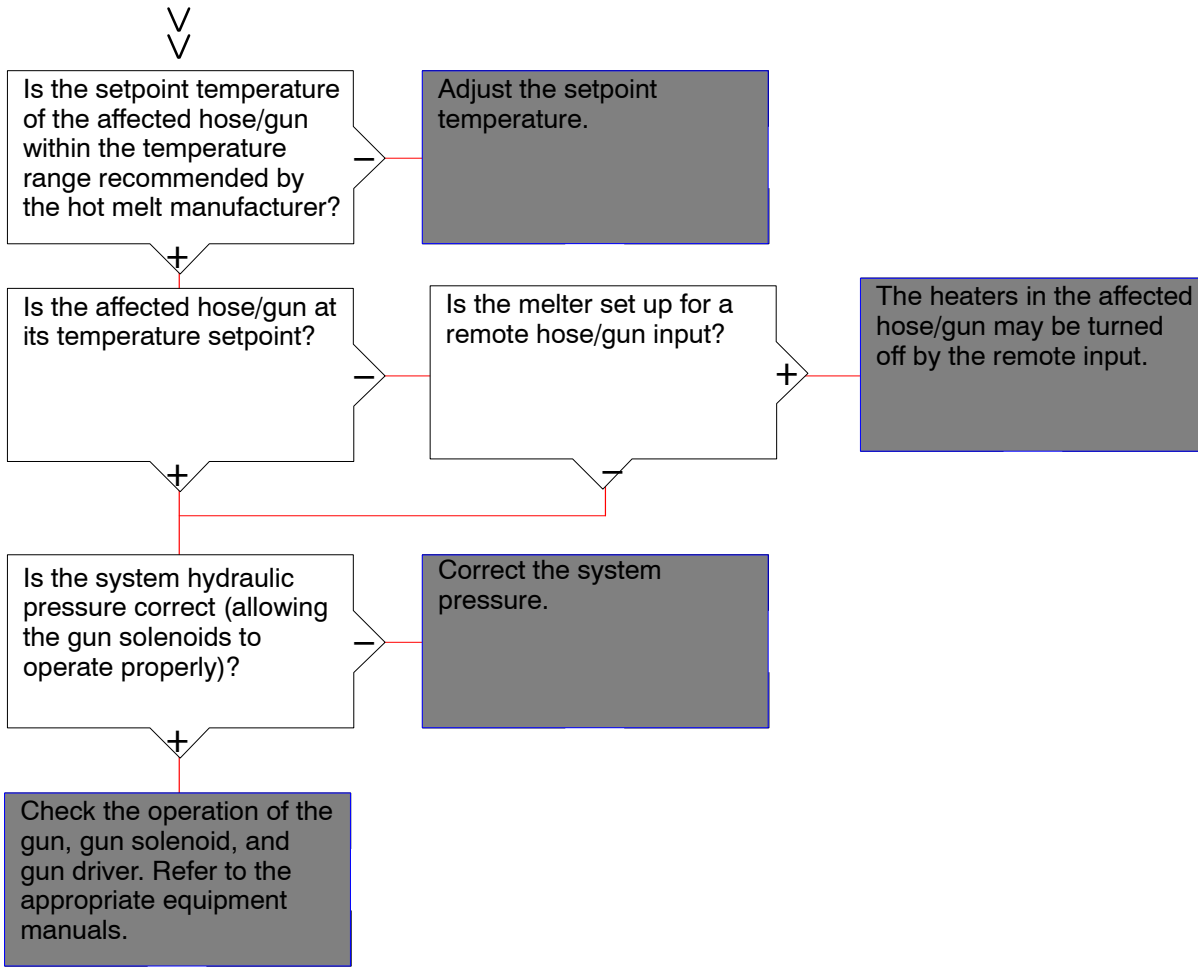

T.5

- No faults >
- Ready LED is illuminated >
- No hot melt output from some guns

This page intentionally left blank.

Section 7 Parts

Using the Illustrated Parts Lists

To order parts, call the Nordson Customer Service Center or your local Nordson representative. Use these five-column parts lists, and the accompanying illustrations, to describe and locate parts correctly. The following chart provides guidance for reading the parts lists.

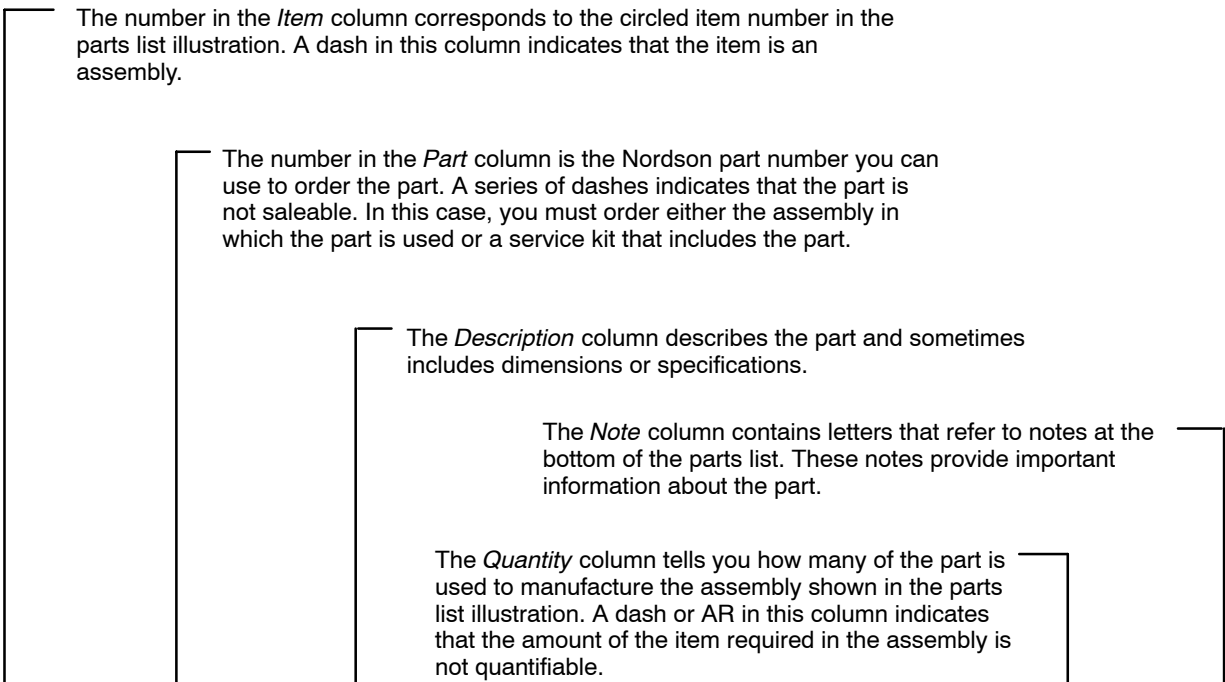

Item	Part	Description	Quantity	Note
—	0000000	Assembly A	—	
1	000000	• Part of assembly A	2	A
2	-----	• • Part of item 1	1	
3	0000000	• • • Part of item 2	AR	
NS	000000	• • • • Part of item 3	2	

NOTE A: Important information about item 1
 AR: As Required
 NS: Not Shown

This page intentionally left blank.

Melter Assembly Part Numbers

This manual applies to all configurations of the Mesa melter. To understand the configuration of your melter, you need to know the melter part number, which is located on the identification plate as shown in Figure 7-1. Refer to the following table as needed to determine the configuration of your melter based on its part number.

Model	Part Number	Pump Type	Number of Hoses/Guns	Tank Capacity	Voltage
Mesa 4	1079895	14:1 dual-acting	2	3.6 kg (8 lb)	200–240V or 400/230V Y
	1079900		2		400/480V Delta
	1079896		4		200–240V or 400/230V Y
	1079901		4		400/480V Delta
	1079911		6		200–240V or 400/230V Y
Mesa 6	1079897	14:1 dual-acting	2	5.4 kg (12 lb)	200–240V or 400/230V Y
	1079902		2		400/480V Delta
	1079898		4		200–240V or 400/230V Y
	1079903		4		400/480V Delta
Mesa 9	1079899	14:1 dual-acting	4	8.6 kg (19 lb)	200–240V or 400/230V Y
	1079904		4		400/480V Delta
Mesa 14	1079905	14:1 dual-acting	4	13.6 kg (30 lb)	200–240V or 400/230V Y
	1079907	21:1 dual-acting	4		
	1079909	10:1 single-acting	4		
	1079906	14:1 dual-acting	6		
	1079908	21:1 dual-acting	6		
	1079910	10:1 single-acting	6		

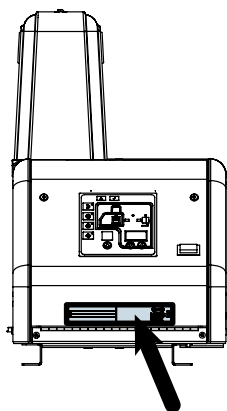

Figure 7-1 Equipment identification plate

Melter Assembly

See Figure 7-2 or 7-3 as applicable.

Item	Part	Description	Quantity	Note
1	-----	CHASSIS ASSY, MESA	1	A
2	-----	ENCLOSURE ASSY.,REAR,MESA	1	B
3	-----	COVER ASSY, LEFT, MESA	1	C
4	1079329	COVER ASSY, RIGHT,2/4H, MESA 4	1	
	1080036	PANEL ASSY,RT,6H,MESA 4	1	D
	1079020	COVER ASSY,RT,MESA 6	1	
	1079375	COVER ASSY, RT, 4H, MESA 9	1	
	1081418	COVER ASSY.,RIGHT,2/4H,MESA 14	1	D
	1081425	COVER ASSY,RT.,6H,MESA 14	1	
5	-----	COVER,TANK W/END CAPS, MESA	1	E
6	-----	LID ASSY,MESA	1	F
9	1079023	PANEL,ASSEMBLY,FRONT,MESA	1	G
10	1017010	SCR,BTN,SKT,M5X10,BL	13 or 14	
12	1082007	ASSEMBLY,PUMP COVER,MESA 4	1	
	1082008	ASSEMBLY,PUMP COVER,MESA 6	1	
	1082009	ASSEMBLY,PUMP COVER,MESA 9	1	
	1083384	COVER,ASSY,PUMP,MESA 14	1	
13	982594	SCR,SKT,M4X10MM,BL	6	
14	983402	WASHER,FLT,M,NARROW,M4,STL,ZN	6 or 10	
15	225454	STRAP,RETAINER,CONTROLLER	2	
16	1040011	NUT,HEX W/EXT TOOTH WASHER,M4	2	
NS	1079039	KIT,SHIP WITH,MESA 4/6, 2 HOSE, 200-240V	1	H
NS	1079050	KIT,SHIP WITH,MESA 4/6/9, 4/6 HOSE, 200-240V	1	H
NS	1083779	KIT,SHIP WITH,MESA 4/6/9,2H/G,400/480V	1	H
NS	1083780	KIT,SHIP WITH, MESA 4/6/9,4H/G,400/480V	1	H
NS	1083415	KIT,SHIP WITH,MESA, 6 HOSE	1	H
NS	1089877	TUBING,MESA4,6MM ODX36LG	2	
NS	1089878	TUBING,MESA6,6MM ODX38LG	2	
NS	1089879	TUBING,MESA9,6MM ODX41LG	2	
NS	1089880	TUBING,MESA14,6MM ODX47LG	2	
NS	1090068	TUBING,MESA14,10MM ODX47LG	2	
22	100349	STRAINER,TANK, MESA 4	1	
	100350	STRAINER,TANK, MESA 6	1	
	111551	STRAINER,TANK, MESA 9	1	
	100353	STRAINER,TANK,3700,FULL,MPL, MESA 14	1	
NS	100352	STRAINER,TANK,3700,MPL, MESA 14	1	
25	983415	WASHER,FLT,M,OVERSIZED,3,STL,Z	3	
26	249675	NUT,HEX,M3,W/EXT TOOTH,WSHR	3	
30	1021983	TAG,WARNING,HOT ADH/HYD PRESS,1.6X6.5	1	
31	982633	CAPSCRM,BTN,SKT,M5X16,BL	1	

Continued...

Item	Part	Description	Quantity	Note
34	1088248	GUARD,SPLASH,CTL,DR,MESA	1	
35	1026451	PLATE,STAMPING,6.812X1.3	1	
36	1086140	TAG,STAMPING,BLANK,DURABLUE	1	
37	985107	RIVET,POP,1/8X.187,CARBON,STL	2	
NOTE A: Refer to <i>Chassis Assembly</i> .				
B: Refer to <i>Recommended Spare Parts</i> for a rear panel service kit part number.				
C: Refer to <i>Left Cover Assembly</i> .				
D: Refer to <i>Right Cover Assembly, M14 6 Hose/Gun Melters</i> .				
E: Refer to <i>Tank Cover Assembly</i> .				
F: Refer to <i>Lid Assembly</i> .				
G: Refer to <i>Front Panel Assembly</i> .				
H: Refer to Section 3, <i>Installation</i> , for the contents of the ship-with kit.				
NS: Not Shown				

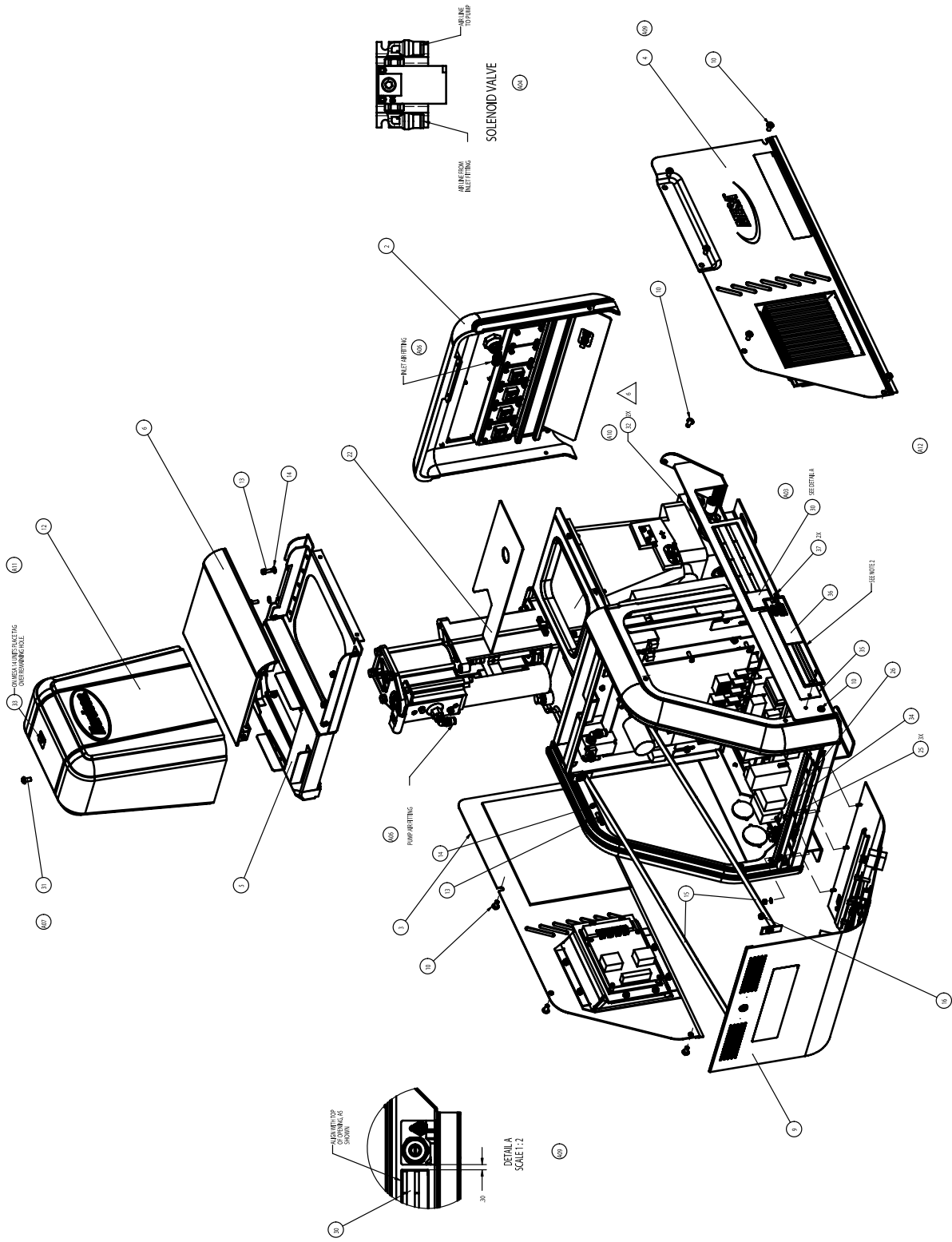

Figure 7-2 Melter assembly parts, 200–240V or 400/230 Y, M4/M6/M9/M14

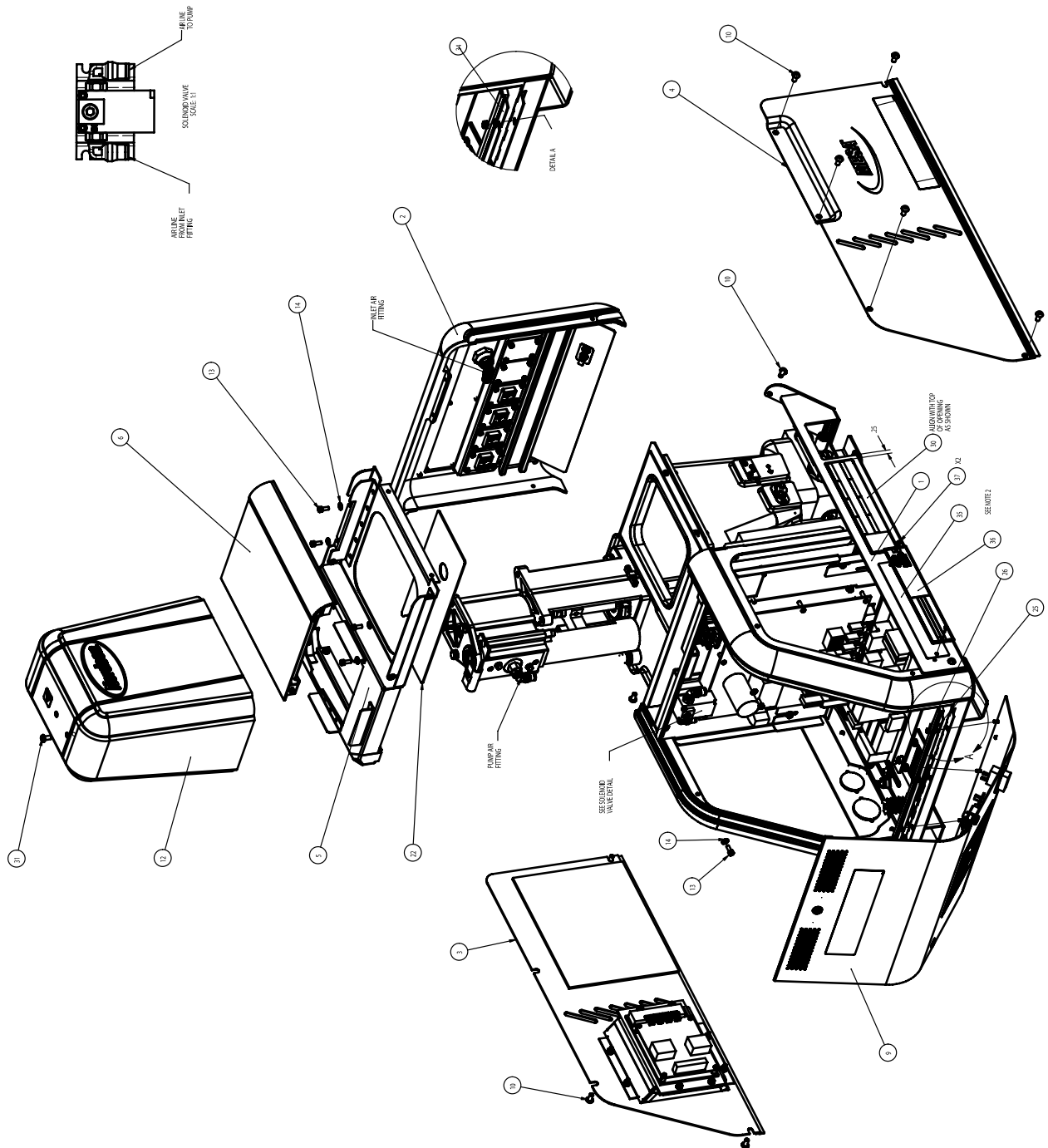

Figure 7-3 Melter assembly parts, 400/480V Delta, M4/M6/M9

Chassis Assembly

The chassis assembly parts vary depending on the configuration of the melter. Refer to the appropriate parts list for your melter. To determine the configuration of your melter, refer to *Melter Assembly Part Numbers* at the beginning of this section.

Chassis Parts, 200–240V or 400/230 Y, M4/M6/M9

See Figures 7-4 and 7-5.

Item	Part	Description	Quantity	Note
1	1092051	BASE, MESA 4,GEN2	1	
	1092052	BASE, MESA 6,GEN2	1	
	1092053	BASE, MESA 9,GEN2	1	
	1092054	BASE, MESA14,GEN2	1	
2	1078968	FRAME ASSY.,MAIN BOARD	1	A
4	-----	EXPANSION BOARD,ASSY,GEN2	1	B
11	983408	WASHER,FLT,M,NARROW,M5,STL,ZN	2	
14	983401	WASHER,LK,M,SPT,M5,STL,ZN	3	
15	984706	NUT,HEX,M5,STL,ZN	1	
17	240674	TAG,GROUND	1	
18	230261	TERMLUG,GROUND,6-14AWG	1	
19	982166	SCR,SKT,M5X16,BL	1	
20	1025295	TAG,PE/G,INPUT POWER,GROUND	1	
21	338368	SCR,PAN,XRECES,M3,5MM,STL,ZINC	6	
22	-----	HARNESS,WIRE,RTD	1	B
23	288309	GASKET,TANK,3100 (MESA 4)	1	
	288310	GASKET,TANK,3400 (MESA 6)	1	
	109904	GASKET,TANK,3500 (MESA 9)	1	
24	-----	HARNESS,WIRE,THERMOSTAT,0OR,26	1	B
25	274667	PLATE,RETAINER RTD	1	
26	1094551	TBACCY,QUICK CONN,25-IN,MALE,DUAL,5	1	
28	330623	COVER,TANK,3100,LEVEL SWITCH (MESA 4)	1	
	288059	COVER,TANK,3400 (MESA 6)	1	
	109905	COVER,TANK,3500 (MESA 9)	1	
29	288311	GASKET,TANK COVER,3100 (MESA 4)	1	
	288312	GASKET,TANK COVER,3400 (MESA 6)	1	
	109906	GASKET,TANK COVER,3500 (MESA 9)	1	
30	900298	COMPOUND,HEAT SINK,5 OZ TUBE,11281	AR	
31	900223	LUBRICANT,O RING,PARKER,4 OZ,30122-5	AR	
32	1090328	STANDOFF,SHORT,MESA,TANK/MANIFOLD	2	
33	1090329	STANDOFF,LONG,MESA,TANK/MANIFOLD	1	
34	984707	NUT,HEX,M8,STL,ZN	3	
36	983404	WASHER,LK,M,SPT,M8,STL,ZN	5	
37	983436	WASHER,LK,M,EXT,8,STL,ZN	3	
38	983402	WASHER,FLT,M,NARROW,M4,STL,ZN	2	
39	983414	WASHER,FLT,M,NARROW,M8,STL,ZN	3	
40	982780	SCR,SKT,M5X10,ZN	6	
41	983403	WASHER,LK,M,SPT,M4,STL,ZN	2	
42	982061	SCR,HEX,CAP,M4X8,BL	2	

Item	Part	Description	Quantity	Note
43	982050	SCR,HEX,CAP,M8X35,BL	3	
44	-----	PUMP,PISTON,14:1,SP-30,G2	1	C
45	1023307	ELBOW, MALE,6 MM TUBE X G 1/8	1	
46	1081854	BRACKET,PUMP COVER,MESA 4,6,9	1	
47	900344	LUBRICANT,NEVER SEEZ,8OZ CAN	AR	
48	288170	PAN,PISTON PUMP,3000	1	
49	-----	TANK/MANIFOLD ASSY	1	D
50	1079588	INSULATION,FRAME,MESA	1	
51	1079175	ADAPTER,1/8 BSPP FEMALE X 1/8NPT MALE	1	
52	1017010	SCR,BTN,SKT,M5X10,BL	4	
57	1079385	BRACKET,INPUT PWR.BRD.,MESA	1	
58	1082730	SPCLNUT, Spring Type,U,M5	1	
59	982308	SCR,PAN,REC,M4X10,ZN	2	
60	1089026	PLATE,SEALING,TANK OPENING,MESA4	1	
	1089027	PLATE,SEALING,TANK OPENING,MESA6	1	
	1089028	PLATE,SEALING,TANK OPENING,MESA9	1	
	1089029	PLATE,SEALING,TANK OPENING,MESA14	1	
<p>NOTE A: Refer to <i>Frame Assembly</i>.</p> <p>B: Refer to <i>Recommended Spare Parts</i> for the part number of this item.</p> <p>C: Refer to <i>Pump Assembly</i>.</p> <p>D: Refer to <i>Tank/Manifold Assembly</i>.</p> <p>AR: As Required</p> <p>NS: Not Shown</p>				

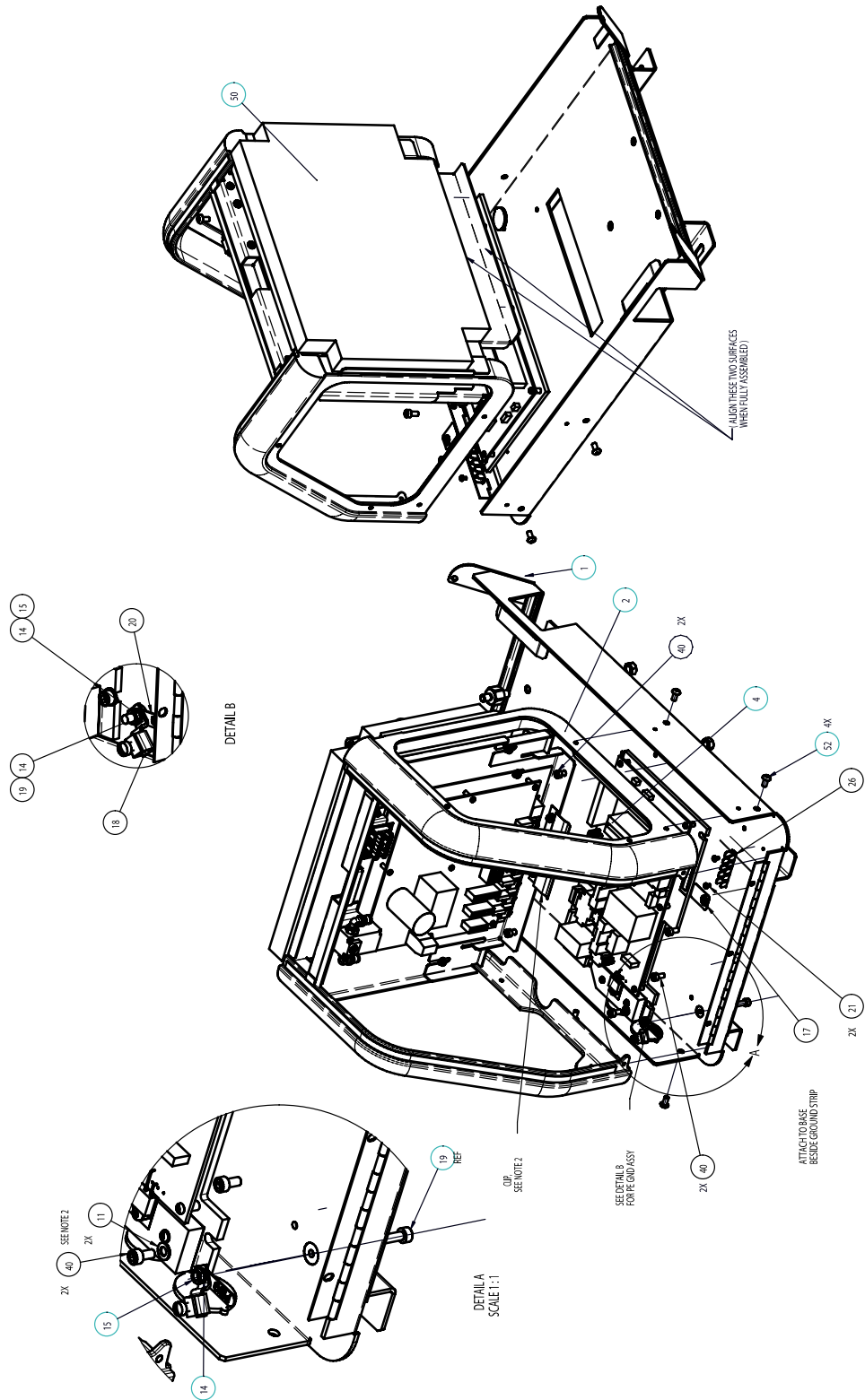

Figure 7-4 Chassis parts, 200–240V or 400/230 Y, M4/M6/M9 (1 of 2)

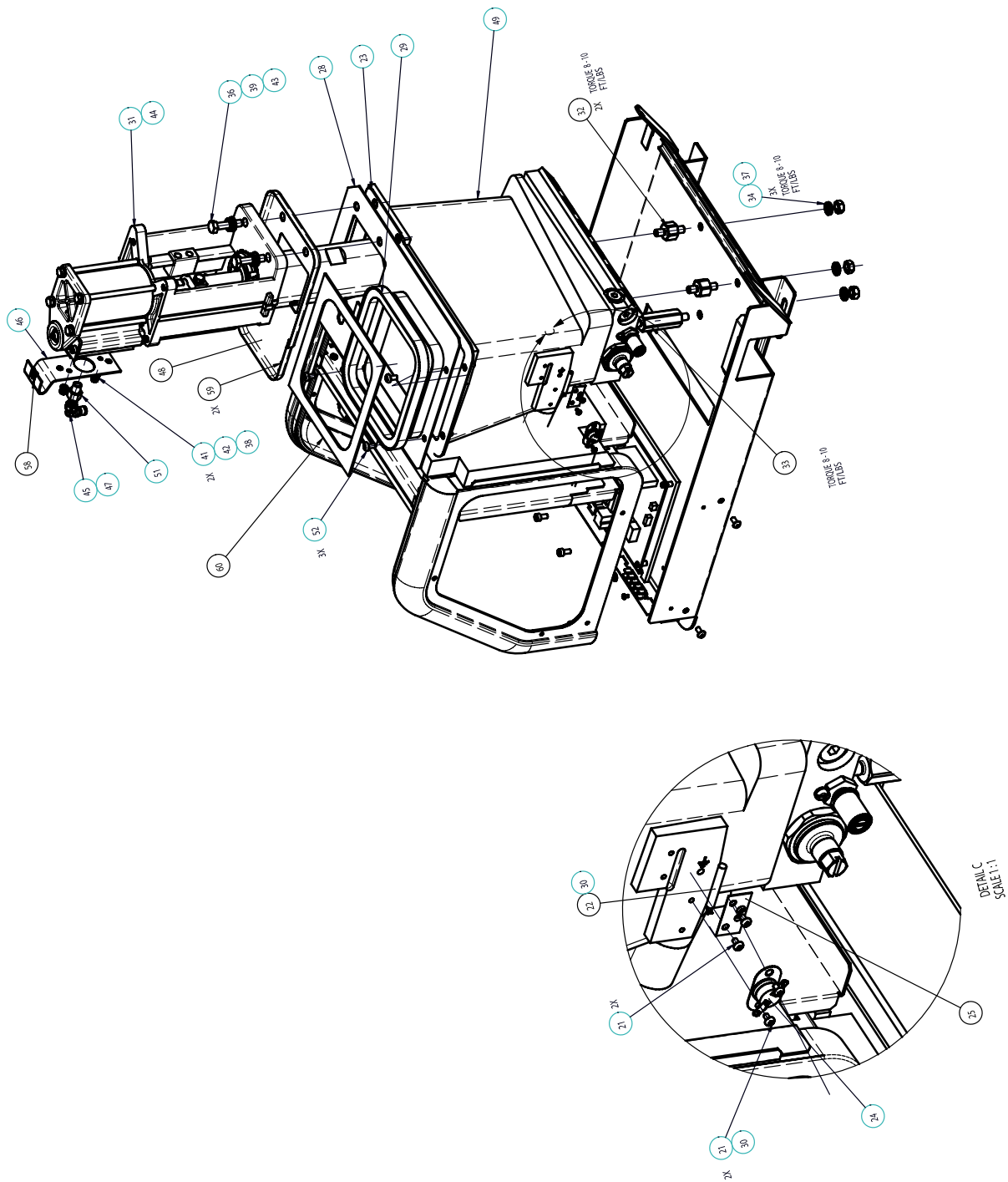

Figure 7-5 Chassis parts, 200–240V or 400/230 Y, M4/M6/M9 (2 of 2)

Chassis Parts, 400/480V, Delta M4/M6/M9

See Figures 7-6 and 7-7.

Item	Part	Description	Quantity	Note
1	1092709	BASE, MESA 4, 400/480V,GEN2	1	
	1092720	BASE, MESA 6 400/480V,GEN2	1	
	1092721	BASE, MESA 9 400/480V,GEN2	1	
2	1083458	FRAME ASSY, MAIN BOARD, MESA 400/480V	1	A
4	-----	EXPANSION BOARD,ASSY,GEN2	1	B
11	983408	WASHER,FLT,M,NARROW,M5,STL,ZN	2	
14	983401	WASHER,LK,M,SPT,M5,STL,ZN	6	
15	984706	NUT,HEX,M5,STL,ZN	5	
17	240674	TAG,GROUND	1	
18	230261	TERMLUG,GROUND,6-14AWG	1	
19	982166	SCR,SKT,M5X16,BL	1	
20	1025295	TAG,PE/G,INPUT POWER,GROUND	1	
21	338368	SCR,PAN,XRECES,M3,5MM,STL,ZINC	6	
22	-----	HARNESS,WIRE,RTD	1	B
23	288309	GASKET,TANK,3100 (MESA 4)	1	
	288310	GASKET,TANK,3400 (MESA 6)	1	
	109904	GASKET,TANK,3500 (MESA 9)	1	
24	-----	HARNESS,WIRE,THERMOSTAT,0OR,26	1	B
25	274667	PLATE,RETAINER RTD	1	
26	1094551	TBACCY,QUICK CONN,25-IN,MALE,DUAL,5	1	
28	330623	COVER,TANK,3100,LEVEL SWITCH (MESA 4)	1	
	288059	COVER,TANK,3400 (MESA 6)	1	
	109905	COVER,TANK,3500 (MESA 9)	1	
29	288311	GASKET,TANK COVER,3100 (MESA 4)	1	
	288312	GASKET,TANK COVER,3400 (MESA 6)	1	
	109906	GASKET,TANK COVER,3500 (MESA 9)	1	
30	900298	COMPOUND,HEAT SINK,5 OZ TUBE,11281	AR	
31	900223	LUBRICANT,O RING,PARKER,4 OZ,30122-5	AR	
32	1090328	STANDOFF,SHORT,MESA,TANK/MANIFOLD	2	
33	1090329	STANDOFF,LONG,MESA,TANK/MANIFOLD	1	
34	984707	NUT,HEX,M8,STL,ZN	3	
35	982107	SCR,HEX,CAP,M8X70,ZN	1	
36	983404	WASHER,LK,M,SPT,M8,STL,ZN	3	
37	983436	WASHER,LK,M,EXT,8,STL,ZN	3	
38	983402	WASHER,FLT,M,NARROW,M4,STL,ZN	2	
39	983414	WASHER,FLT,M,NARROW,M8,STL,ZN	3	
40	982780	SCR,SKT,M5X10,ZN	4	
41	983403	WASHER,LK,M,SPT,M4,STL,ZN	2	
42	982061	SCR,HEX,CAP,M4X8,BL	2	
43	982050	SCR,HEX,CAP,M8X35,BL	3	
44	-----	PUMP,PISTON,14:1,SP-30,G2	1	C
45	1023307	ELBOW, MALE,6 MM TUBE X G 1/8	1	
46	1081854	BRACKET,PUMP COVER,MESA 4,6,9	1	
47	900344	LUBRICANT,NEVER SEEZ,8OZ CAN	AR	
48	288170	PAN,PISTON PUMP,3000	1	
49	-----	TANK/MANIFOLD ASSY	1	D
50	1083619	INSULATION, FRAME, MESA 400/480V	1	

Item	Part	Description	Quantity	Note
51	1079175	ADAPTER,1/8 BSPP FEMALE X 1/8NPT MALE	1	
52	1017010	SCR,BTN,SKT,M5X10,BL	4	
58	1082730	SPCLNUT, Spring Type,U,M5	1	
59	982308	SCR,PAN,REC,M4X10,ZN (not present on M4 melters)	2	
60	1083505	PLATE, BASE, WIRE CHANNEL, MESA 400/480V	1	
61	1083506	GASKET,BASE,WIRE CHANNEL,MESA 400/480V	1	
62	1089026	PLATE,SEALING,TANK OPENING,MESA4	1	
	1089027	PLATE,SEALING,TANK OPENING,MESA6	1	
	1089028	PLATE,SEALING,TANK OPENING,MESA9	1	

NOTE A: Refer to *Frame Assembly*.

B: Refer to *Recommended Spare Parts* for the part number of this item.

C: Refer to *Pump Assembly*.

D: Refer to *Tank/Manifold Assembly*.

AR: As Required

NS: Not Shown

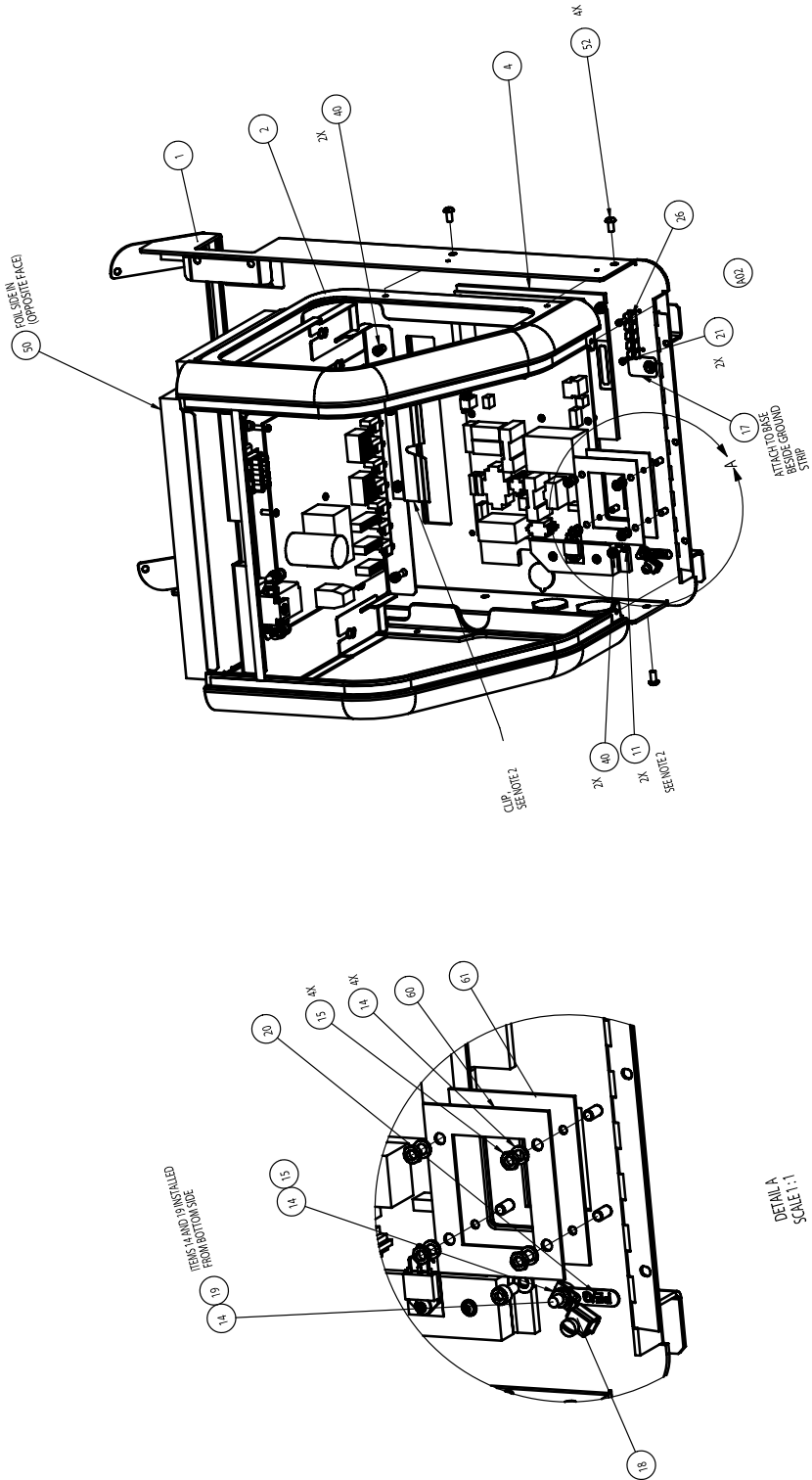

Figure 7-6 Chassis parts, 400/480V Delta, M4/M6/M9 (1 of 2)

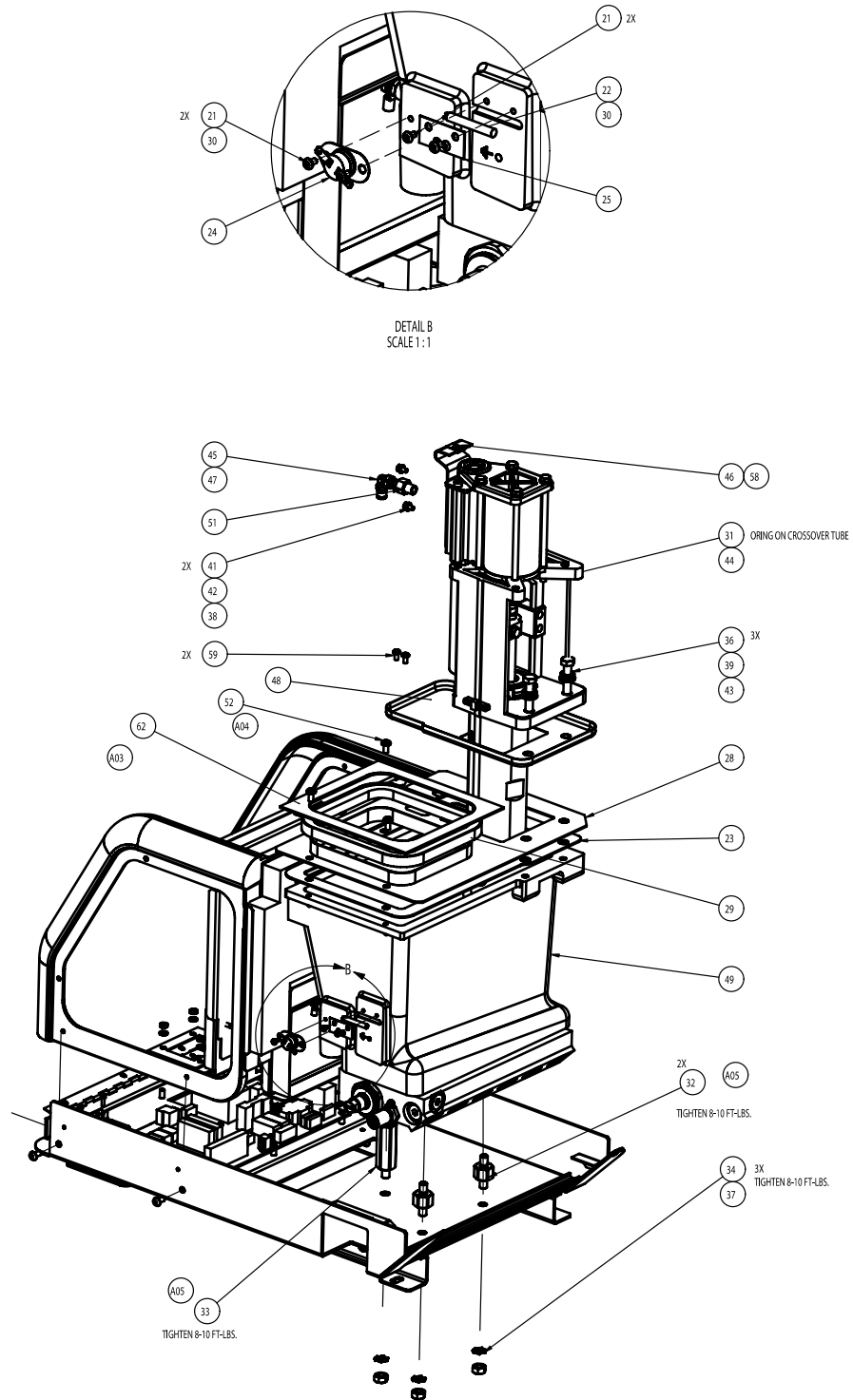

Figure 7-7 Chassis parts, 400/480V Delta, M4/M6/M9 (2 of 2)

Chassis Parts, M14, 14:1 Pump

See Figures 7-8 through 7-10.

Item	Part	Description	Quantity	Note
1	1092054	BASE,MESA,14 LITER,GEN2	1	
2	1078968	FRAME ASSY.,MAIN BOARD	1	A
4	-----	EXPANSION BOARD,ASSY,GEN2	1	B
11	983408	WASHER,FLT,M,NARROW,M5,STL,ZN	4	
14	983401	WASHER,LK,M,SPT,M5,STL,ZN	9	
15	984706	NUT,HEX,M5,STL,ZN	7	
17	240674	TAG,GROUND	1	
18	230261	TERMLUG,GROUND,6-14AWG	1	
19	982166	SCR,SKT,M5X16,BL	1	
20	1025295	TAG,PE/G,INPUT POWER,GROUND	1	
21	338368	SCR,PAN,XRECES,M3,5MM,STL,ZINC	6	
22	-----	HARNESS,WIRE,RTD	1	B
23	100452	GASKET,TANK,3700	1	
24	-----	HARNESS,WIRE,THERMOSTAT,0OR,26	1	B
25	274667	PLATE,RETAINER RTD	1	
26	1094551	TBACCY,QUICK CONN,25-IN,MALE,DUAL,5	1	
27	982725	SCR,PAN,REC,M5X10,ZN	6	
28	100342	COVER,TANK,3700	1	
29	100454	GASKET,TANK COVER,3700	1	
30	900298	COMPOUND,HEAT SINK,5 OZ TUBE,11281	0	
31	900223	LUBRICANT,O RING,PARKER,4 OZ,30122-5	0	
32	1090328	STANDOFF,SHORT,MESA,TANK/MANIFOLD	2	
33	1090329	STANDOFF,LONG,MESA,TANK/MANIFOLD	1	
34	984707	NUT,HEX,M8,STL,ZN	3	
35	982107	SCR,HEX,CAP,M8X70,ZN	1	
36	983404	WASHER,LK,M,SPT,M8,STL,ZN	3	
37	983436	WASHER,LK,M,EXT,8,STL,ZN	3	
38	983402	WASHER,FLT,M,NARROW,M4,STL,ZN	2	
39	983414	WASHER,FLT,M,NARROW,M8,STL,ZN	3	
40	982780	SCR,SKT,M5X10,ZN	6	
41	983403	WASHER,LK,M,SPT,M4,STL,ZN	2	
42	982061	SCR,HEX,CAP,M4X8,BL	2	
43	982050	SCR,HEX,CAP,M8X35,BL	3	
44	-----	PUMP,PISTON,14:1,SP-30,G2	1	C
45	1023307	ELBOW, MALE,6 MM TUBE X G 1/8	1	
46	1081854	BRACKET,PUMP COVER,MESA 4,6,9	1	
47	900344	LUBRICANT,NEVER SEEZ,8OZ CAN	0	
48	288170	PAN,PISTON PUMP,3000	1	
49	-----	TANK/MANIFOLD ASSY, MESA 14	1	D
50	1079588	INSULATION,FRAME,MESA	1	
51	1079175	ADAPTER,1/8 BSPP FEMALE X 1/8NPT MALE	1	
52	1017010	SCR,BTN,SKT,M5X10,BL	6	
58	1082730	SPCLNUT, Spring Type,U,M5	1	
59	982308	SCR,PAN,REC,M4X10,ZN	2	

Item	Part	Description	Quantity	Note
<p>NOTE A: Refer to <i>Frame Assembly</i>.</p> <p>B: Refer to <i>Recommended Spare Parts</i> for the part number of this item.</p> <p>C: Refer to <i>Pump Assembly</i>.</p> <p>D: Refer to <i>Tank/Manifold Assembly</i>.</p> <p>AR: As Required</p> <p>NS: Not Shown</p>				

Chassis Parts, M14, 21:1 Pump

See Figures 7-8 through 7-10.

Item	Part	Description	Quantity	Note
1	1092054	BASE,MESA,14 LITER,GEN2	1	
2	1081923	FRAME ASSY.,MAIN BOARD,10:1 & 21:1	1	A
4	-----	EXPANSION BOARD,ASSY,GEN2	1	B
11	983408	WASHER,FLT,M,NARROW,M5,STL,ZN	2	
14	983401	WASHER,LK,M,SPT,M5,STL,ZN	6	
15	984706	NUT,HEX,M5,STL,ZN	1	
17	240674	TAG,GROUND	1	
18	230261	TERMLUG,GROUND,6-14AWG	1	
19	982166	SCR,SKT,M5X16,BL	1	
20	1025295	TAG,PE/G,INPUT POWER,GROUND	1	
21	338368	SCR,PAN,XRECES,M3,5MM,STL,ZINC	1	
22	-----	HARNESS,WIRE,RTD	1	B
23	100452	GASKET,TANK,3700	1	
24	-----	HARNESS,WIRE,THERMOSTAT,0OR,26	1	B
25	274667	PLATE,RETAINER RTD	1	
26	1094551	TBACCY,QUICK CONN,25-IN,MALE,DUAL,5	1	
27	982725	SCR,PAN,REC,M5X10,ZN	6	
28	100342	COVER,TANK,3700	1	
29	100454	GASKET,TANK COVER,3700	1	
30	900298	COMPOUND,HEAT SINK,5 OZ TUBE,11281	AR	
31	900223	LUBRICANT,O RING,PARKER,4 OZ,30122-5	AR	
32	1090328	STANDOFF,SHORT,MESA,TANK/MANIFOLD	2	
33	1090329	STANDOFF,LONG,MESA,TANK/MANIFOLD	1	
34	984707	NUT,HEX,M8,STL,ZN	3	
35	982107	SCR,HEX,CAP,M8X70,ZN	1	
36	983404	WASHER,LK,M,SPT,M8,STL,ZN	3	
37	983436	WASHER,LK,M,EXT,8,STL,ZN	3	
38	983035	WASHER,FLT,M,REG,M5,STL,ZN	2	
39	983414	WASHER,FLT,M,NARROW,M8,STL,ZN	3	
40	982780	SCR,SKT,M5X10,ZN	5	
41	983401	WASHER,LK,M,SPT,M5,STL,ZN	2	
42	982178	SCR,SKT,M5X50,BL	2	
43	982050	SCR,HEX,CAP,M8X35,BL	3	
44	-----	PUMP,PISTON,21:1,MESA,W/ACT.	1	C
45	1083802	FITTING,10MM TUBE,90 DEG,G 1/4	1	
47	900344	LUBRICANT,NEVER SEEZ,8OZ CAN	AR	
48	288170	PAN,PISTON PUMP,3000	1	
49	-----	TANK/MANIFOLD ASSY, MESA 14	1	D
50	1079588	INSULATION,FRAME,MESA	1	
51	1079175	ADAPTER,1/8 BSPP FEMALE X 1/8NPT MALE	1	
52	1017010	SCR,BTN,SKT,M5X10,BL	6	
53	1083787	EXPANDER,MALE TO FEMALE,G 1/8 X G 1/4	1	
59	982308	SCR,PAN,REC,M4X10,ZN	2	

Item	Part	Description	Quantity	Note
NOTE	A: Refer to <i>Frame Assembly</i> .	B: Refer to <i>Recommended Spare Parts</i> for the part number of this item.	C: Refer to <i>Pump Assembly</i> .	D: Refer to <i>Tank/Manifold Assembly</i> .
AR:	As Required			

Chassis Parts, M14, 10:1 Pump

See Figures 7-8 through 7-10.

Item	Part	Description	Quantity	Note
1	1092054	BASE,MESA,14 LITER,GEN2	1	
2	1081923	FRAME ASSY.,MAIN BOARD,10:1 & 21:1	1	A
4	-----	EXPANSION BOARD,ASSY,GEN2	1	B
11	983408	WASHER,FLT,M,NARROW,M5,STL,ZN	2	
14	983401	WASHER,LK,M,SPT,M5,STL,ZN	6	
15	984706	NUT,HEX,M5,STL,ZN	1	
17	240674	TAG,GROUND	1	
18	230261	TERMLUG,GROUND,6-14AWG	1	
19	982166	SCR,SKT,M5X16,BL	1	
20	1025295	TAG,PE/G,INPUT POWER,GROUND	1	
21	338368	SCR,PAN,XRECES,M3,5MM,STL,ZINC	4	
22	-----	HARNESS,WIRE,RTD	1	B
23	100452	GASKET,TANK,3700	1	
24	-----	HARNESS,WIRE,THERMOSTAT,0OR,26	1	B
25		PLATE,RETAINER RTD	1	
26	1094551	TBACCY,QUICK CONN,25-IN,MALE,DUAL,5	1	
27	982725	SCR,PAN,REC,M5X10,ZN	6	
28	100342	COVER,TANK,3700	1	
29	100454	GASKET,TANK COVER,3700	1	
30	900298	COMPOUND,HEAT SINK,5 OZ TUBE,11281	0	
31	900223	LUBRICANT,O RING,PARKER,4 OZ,30122-5	0	
32	1090328	STANDOFF,SHORT,MESA,TANK/MANIFOLD	2	
33	1090329	STANDOFF,LONG,MESA,TANK/MANIFOLD	1	
34	984707	NUT,HEX,M8,STL,ZN	3	
35	982107	SCR,HEX,CAP,M8X70,ZN	1	
36	983404	WASHER,LK,M,SPT,M8,STL,ZN	3	
37	983436	WASHER,LK,M,EXT,8,STL,ZN	3	
39	983414	WASHER,FLT,M,NARROW,M8,STL,ZN	3	
40	982780	SCR,SKT,M5X10,ZN	5	
43	982050	SCR,HEX,CAP,M8X35,BL	3	
44	-----	PUMP,ASSY,W/SOL,10:1,MESA 14	1	C
48	288170	PAN,PISTON PUMP,3000	1	
49	-----	TANK/MANIFOLD ASSY, MESA 14	1	D
50	1079588	INSULATION,FRAME,MESA	1	
52	1017010	SCR,BTN,SKT,M5X10,BL	6	
56	1080142	BLOCK, TERMINAL,ASSY,4 STA.,MESA	1	
59	982059	SCR,SKT,M4X8,BL	2	

Continued...

NOTE A: Refer to *Frame Assembly*.

B: Refer to *Recommended Spare Parts* for the part number of this item.

C: Refer to *Pump Assembly*.

D: Refer to *Tank/Manifold Assembly*.

AR: As Required

Chassis Parts, M14, 10:1 Pump (contd)

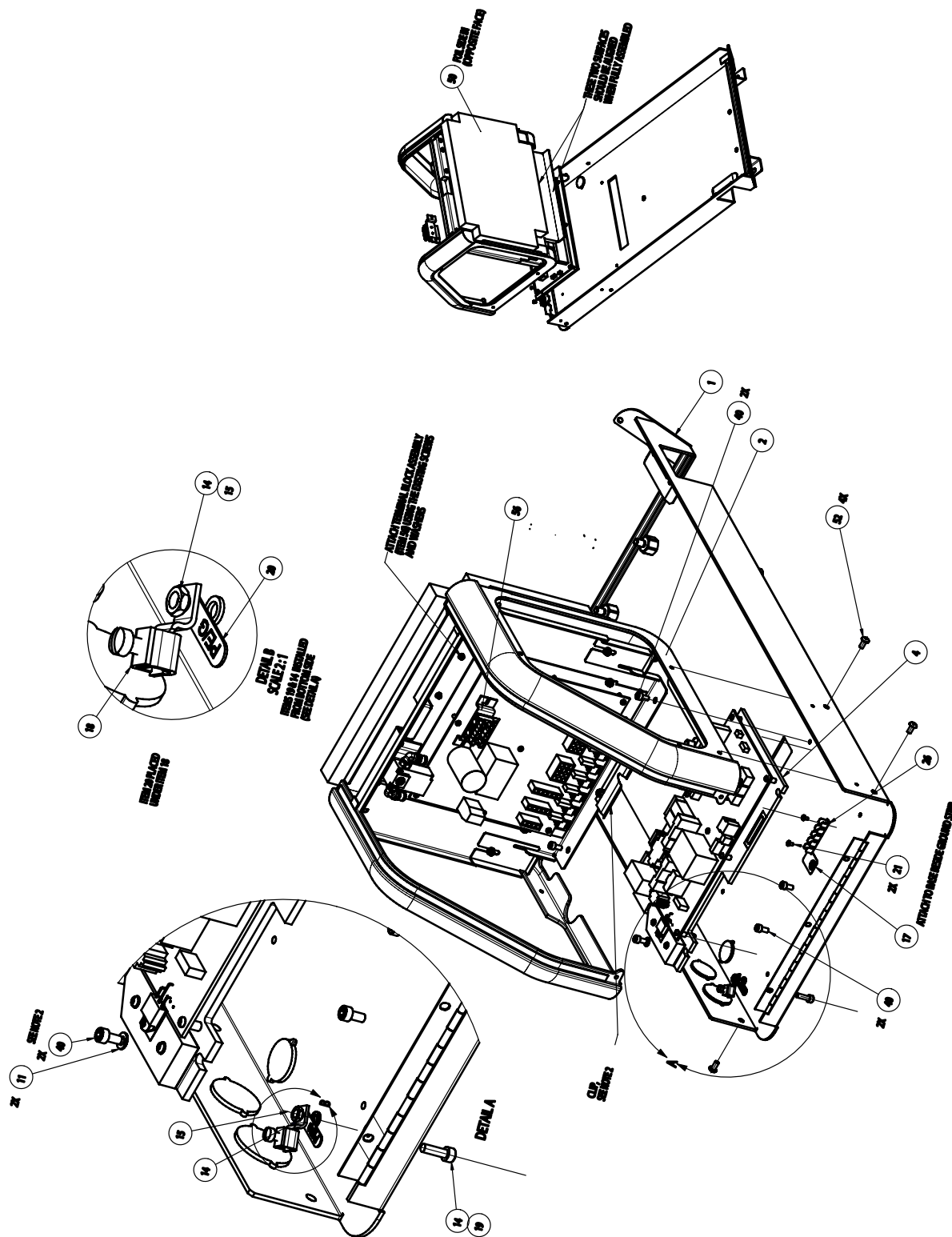
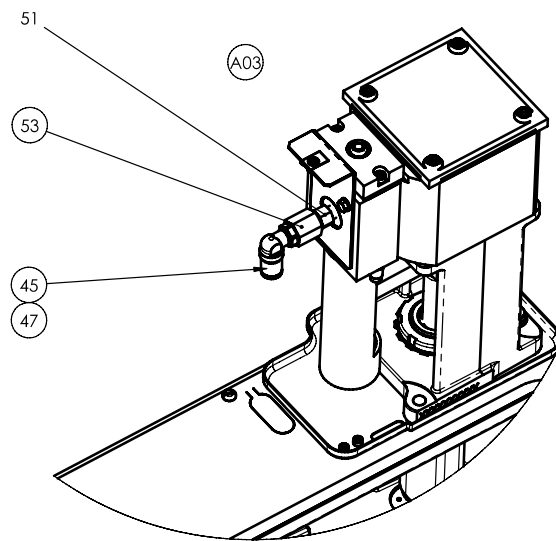
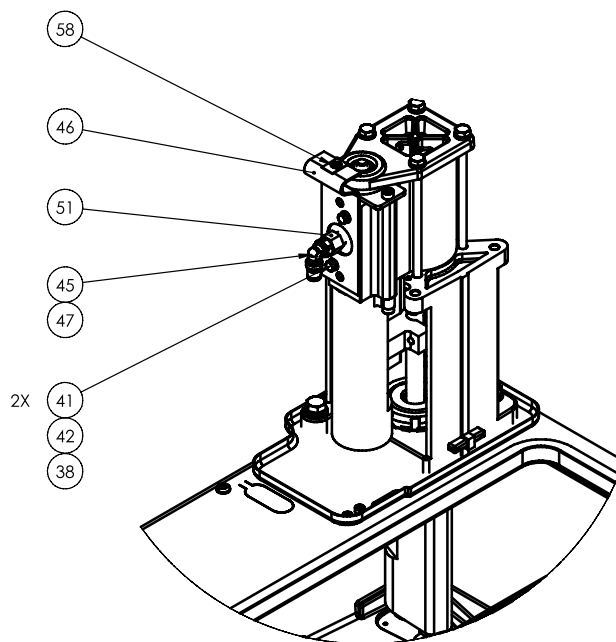

Figure 7-8 Chassis parts, M14 (1 of 3)

Chassis Parts, M14, 10:1 Pump (contd)



21:1 PUMP CONFIGURATION



14:1 PUMP CONFIGURATION

Figure 7-10 Chassis parts, M14 (3 of 3)

Transformer Base Assembly (400/480V Delta)

See Figure 7-11.

Item	Part	Description	Quantity	Note
1	1083760	BASE, TRANSFORMER, MESA, 400/480V	1	
2	1083767	COVER ASSY, TRANS, MESA 400/480V	1	
3	1083769	LID ASSY, TRANSFORMER, MESA 400/480V	1	
4	-----	MODULE ASSY, POWER, DISTRIBUTION, MESA	1	A
5	1083765	COVER ASSY,POWER ACCESS, MESA 400/480V	2	
6	982780	SCR,SKT,M5X10,ZN	22	
7	1040056	PANELTB,3POS,750V,76A,SCREW,G10	1	
8	1040003	SCR,SKT,M4X25,ZN	2	
9	984706	NUT,HEX,M5,STL,ZN	4 or 8	
10	983401	WASHER,LK,M,SPT,M5,STL,ZN	10 or 14	
11	230261	TERMLUG,GROUND,6-14AWG	1	
12	-----	PWRXFMR,AUTO,1.5KVA,400/480PRI,230SEC	1 or 2	A
13	240674	TAG,GROUND	3	
14	983035	WASHER,FLT,M,REG,M5,STL,ZN	4 or 8	
15	1040008	PLATE,STAMPING,BLANK XFMR BASE	1	
16	985109	RIVET,POP, 1/8X.125,CARBON STL	2	
17	1024619	WIRE ASSY,GRND,10GA,SPD/RING,6INCH LG	4	
18	1083986	WIRE ASSY,GND,10GA,SPD/RING,16INCH LG	2	
19	1023299	LUG,45,SINGLE,M5 X .032	1	
20	984702	NUT,HEX,M5,BRASS	8	
21	1040011	NUT,HEX W/EXT TOOTH WASHER,M4	2	
22	1040654	TAG,STAMPING,2.938X2.188,TRANS BASE	1	
NS	1093337	WIRE,HARN,GEN2,400/480,MESA	1	
24	1025295	TAG,PE/G,INPUT POWER,GROUND	1	
NS	182105	CABLETIE,4IN,302F	2	
26	1083778	TAG,MELTER PN'S USED W/ XFMR,MESA	1	
NS	1084241	KIT,SHIP WITH,MESA,XFMR,BASE	1	B

NOTE A: Refer to *Recommended Spare Parts* for the part number of this item.
 B: Refer to Appendix C, *400/480 Volt Mesa Adhesive Melters*, for the contents of the ship-with kit.
 NS: Not Shown

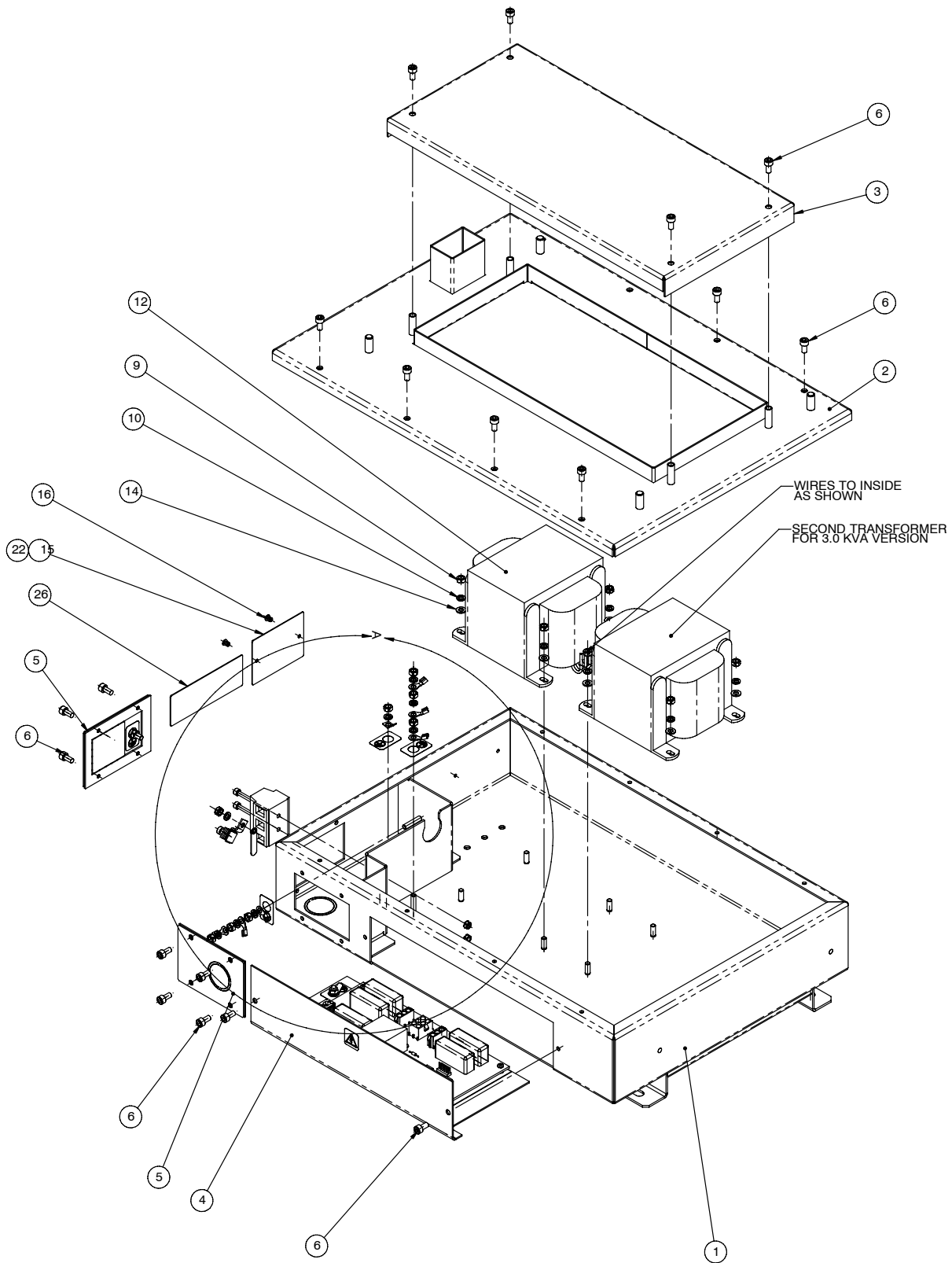

Figure 7-11 Transformer base assembly, 400/480V Delta (1 of 2)

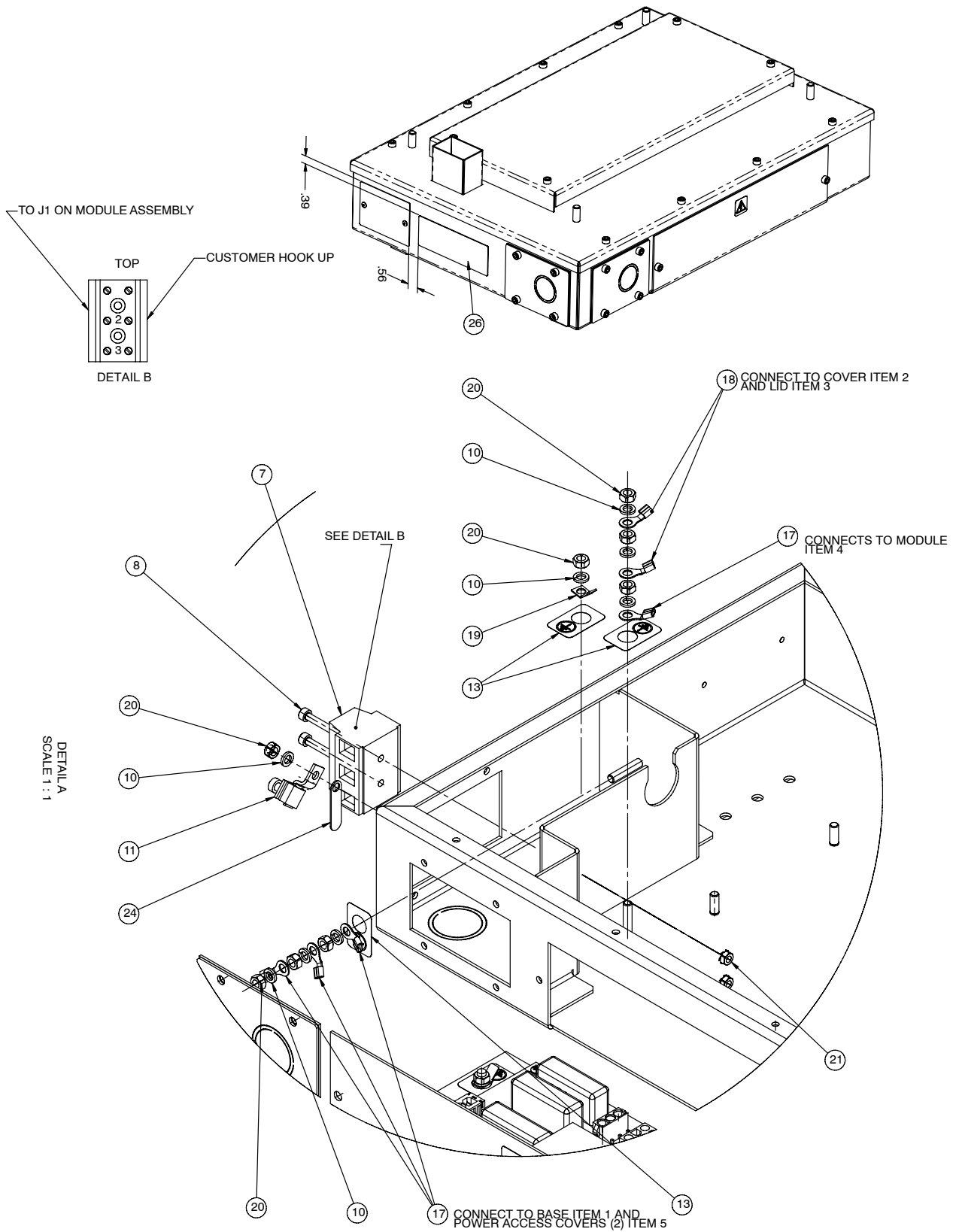

Figure 7-12 Transformer base assembly, 400/480V Delta (2 of 2)

This page intentionally left blank.

Frame Assembly

The frame assembly includes the bulkhead assembly and the solenoid assembly. The solenoid assembly parts vary depending on the configuration of the melter. Refer to the appropriate parts list for your melter. To determine the configuration of your melter, refer to *Melter Assembly Part Numbers* at the beginning of this section.

Frame Parts

See Figure 7-13 or 7-14 as applicable.

Item	Part	Description	Quantity	Note
1	1078970	BULKHEAD ASSY,MAIN BOARD	1	
	1081278	BULKHEAD,ASSY,MAIN BOARD,10:1 & 21:1	1	
2	1081686	PANEL,BULKHEAD,TANK,MESA, 200-240V	1	A
	1083630	BULKHEAD ASSY, TANK, MESA 400/480V	1	A
3	1077704	FRAME,LEFT,MESA,ALUMINUM	1	
4	1077703	FRAME,RIGHT,MESA,ALUMINUM	1	
5	982201	SCR,SKT,M5X8,BL	2	
6	288221	GASKET,.354X.216,MPL,3000V	3.6 or 4.1 ft	
NOTE A: Refer to <i>Bulkhead Parts</i> .				

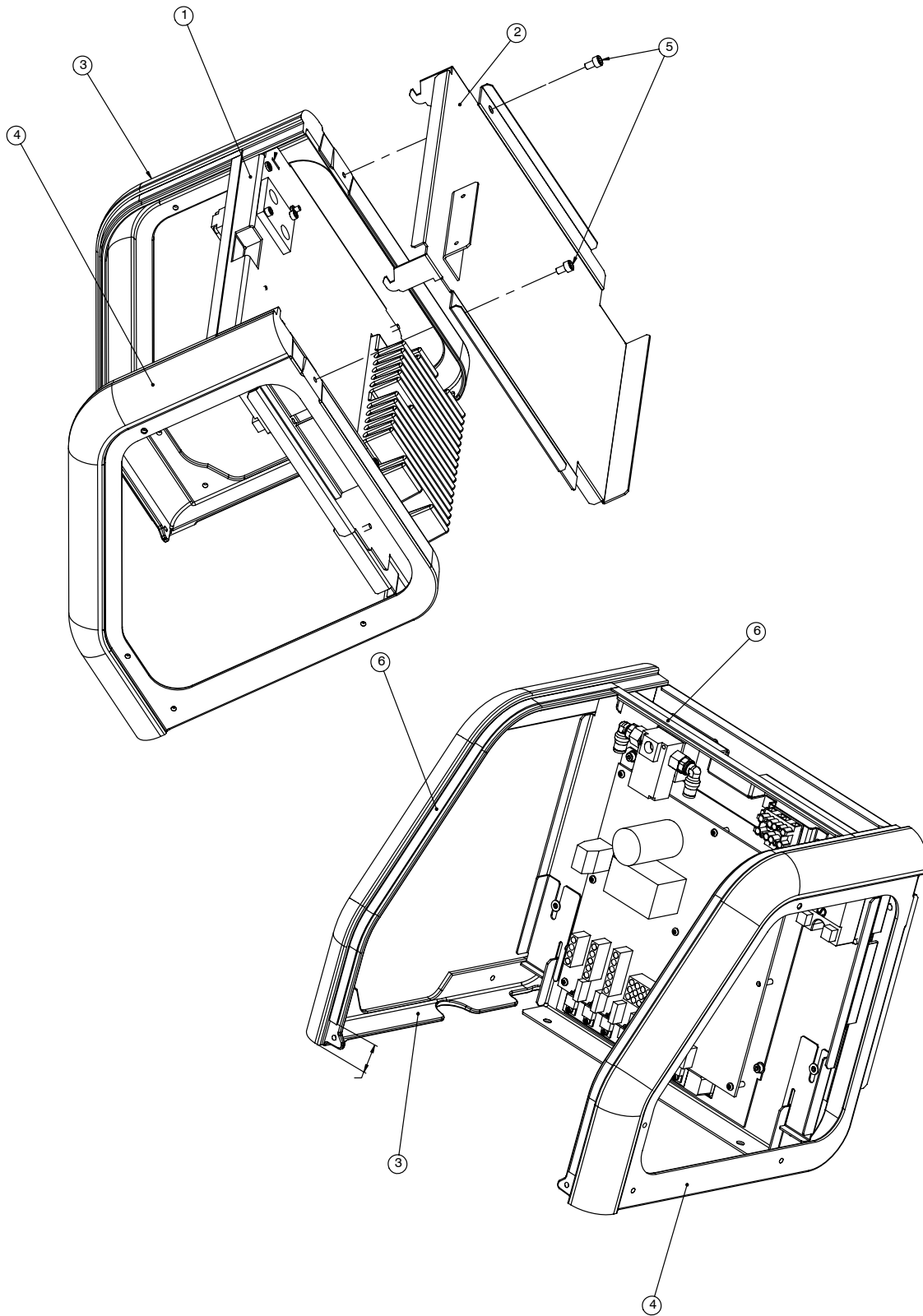

Figure 7-13 Frame parts, 200–240V or 400/230 Y

Frame Parts *(contd)*

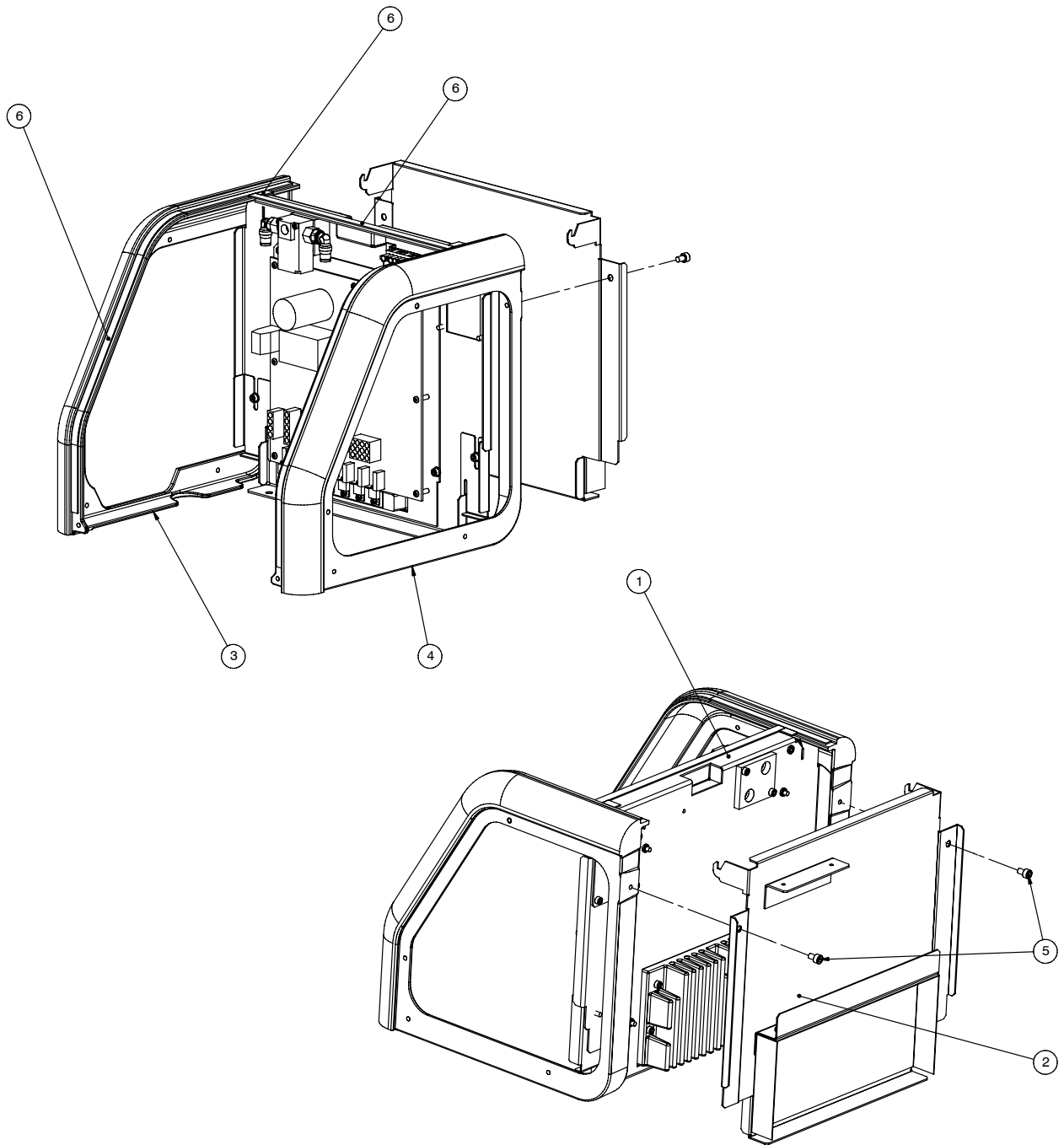

Figure 7-14 Frame parts, 400/480V Delta

This page intentionally left blank.

Bulkhead Parts

See Figure 7-15 as applicable.

Item	Part	Description	Quantity	Note
1	1092597	PANEL,EL.BULKHD,MESA GEN2	1	
3	1078979	SOLENOID ASSY, 14:1	1	A
	1081887	SOLENOID ASSY, MESA,10:1 & 21:1	1	A
4	982664	SCR,SKT,LOW,M3X5,BL	2	
5	1078922	PLATE, PROTECTOR,WATER,LF	1	
6	1078923	PLATE,PROTECTOR,WATER,RT.	1	
7	-----	BOARD, MAIN W/HT SINK ASSY, DURA/ALTA	1	
8	983402	WASHER,FLT,M,NARROW,M4,STL,ZN	6	
9	982594	SCR,SKT,M4X10MM,BL	8	
10	983411	WASHER,FLT,M,NARROW,M3,STL,ZN	2	
12	171856	SHUNT,.1IN,2POS	1	
14	982201	SCR,SRT,M5X8,BL	2	
	981171	SCR,SKT,10-32X1.250,ZN (MESA 14)	2	
16	1092602	CLIP,BOARD,MESA,GEN2	1	
17	1052143	NUT,HEX,W/EXT TOOTH WASHER,M5,STL	2	
NOTE A: Refer to <i>Solenoid Parts</i>				

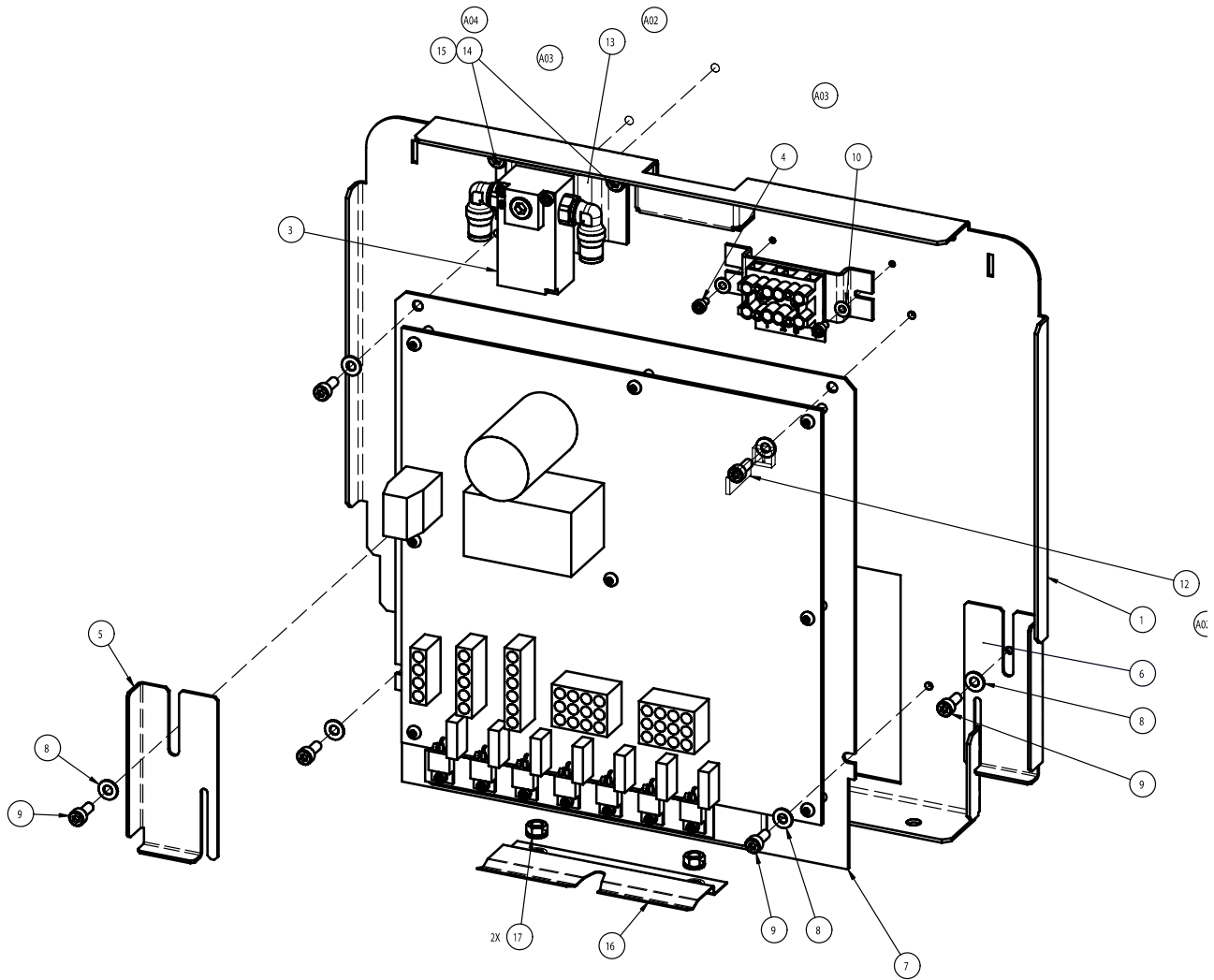

Figure 7-15 Bulkhead assembly parts

Solenoid Parts, 14:1 Pumps

See Figure 7-16.

Item	Part	Description	Quantity	Note
—	1078979	SOLENOID ASSY, 14:1	—	
2	1089435	• SOLENOID,ASSY,3-WAY,24VDC,G1/8	1	
4	972126	• ELBOW, MALE,6 MM TUBE X G 1/8	2	
5	982024	• SCR,SKHD,M3 X 25MM,STL,BLK,CL 12.9	2	
6	1089806	• BRACKET,SOLENOID MOUNT,MESA	1	

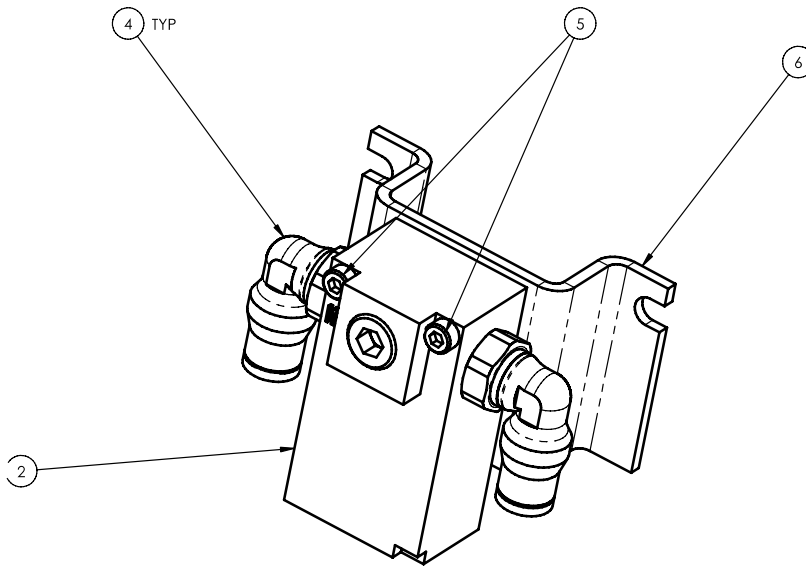

Figure 7-16 Solenoid parts, 14:1 pumps

Solenoid Parts, 10:1 and 21:1 Pumps

See Figure 7-17.

Item	Part	Description	Quantity	Note
—	1081887	SOLENOID ASSY, MESA,10:1 & 21:1	—	
1	1081893	• SOLENOID ASSY, 2 WAY,24VDC,1/4	1	
3	972125	• FITTING,10MM TUBE,90 DEG,G 1/4	2	
4	981893	• SCR,SKT,10-32X,.500,ZN,14431-FDF	2	
5	983021	• WASHER,FLT,E,.203X.406X.040,BR	2	
6	1089806	• BRACKET,SOLENOID MOUNT,MESA	1	

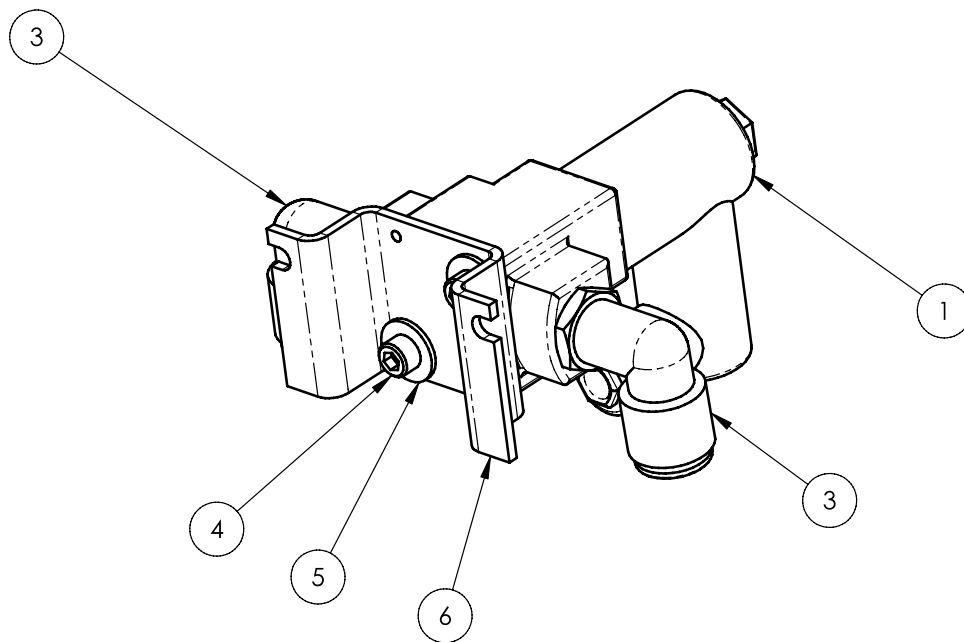

Figure 7-17 Solenoid parts, 10:1 and 21:1 pumps

Lid Assembly

See Figure 7-18.

Item	Part	Description	Quantity	Note
—	1081502	LID ASSY,MESA 4	—	
—	1081503	LID ASSY,MESA 6	—	
—	1081504	LID ASSY,MESA 9	—	
—	1081275	LID ASSY,MESA 14	—	
1	-----	• HINGE,LID,MESA	1	
2	-----	• LID,OUTER	1	
3	-----	• HANDLE,LID,PLASTIC,MESA	1	
4	986320	• RETAINING RING,EXT, 25,E-RING	1	
5	220571	• SPRING,COMP,.36ODX.038X1.75LG	1	
6	-----	• LID,INNER	1	
7	-----	• LID SUPPORT	1	
8	982372	• SCR,SKT,M5X12,BL	2	
9	983035	• WASHER,FLT,M,REG,M5,STL,ZN	6	
10	982201	• SCR,SKT,M5X8,BL	4	
11	982368	• SCR,PAN,REC,M5X10,NYLOK	2	

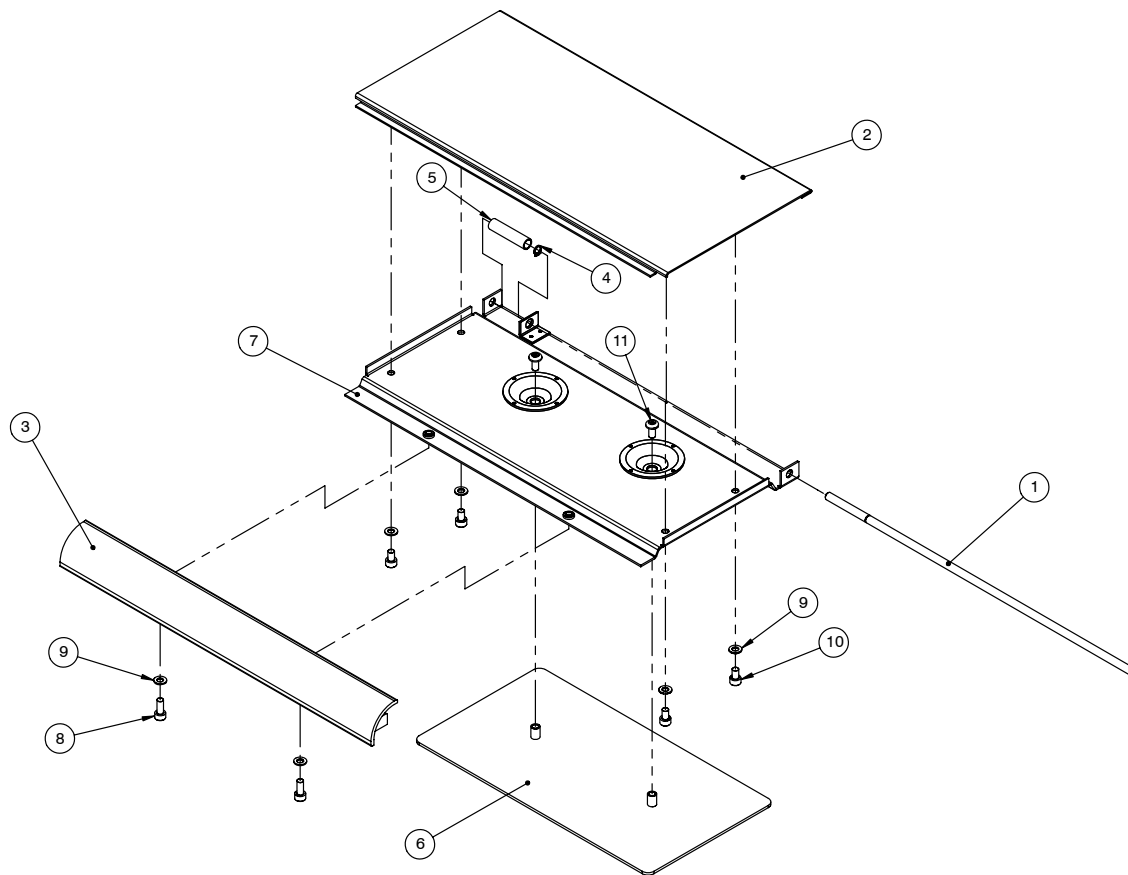

Figure 7-18 Lid assembly

This page intentionally left blank.

Tank/Manifold Assembly

The tank/manifold assembly parts vary depending on the configuration of the melter. Refer to the appropriate parts list for your melter. To determine the configuration of your melter, refer to *Melter Assembly Part Numbers* at the beginning of this section.

Tank/Manifold Parts, 200–240V or 400/230 Y

See Figure 7-19.

Item	Part	Description	Quantity	Note
1	900344	LUBRICANT,NEVER SEEZ,8OZ CAN	AR	
2	288017	TANK,MACHINED, MESA 4	1	
	139920	TANK,MACHINED, MESA 6	1	
	143743	TANK,MACHINED, MESA 9	1	
	288005	TANK,MACHINED, MESA 14	1	
NS	144869	INSULATION,TANK, MESA 4	1	
NS	288307	INSULATION,TANK, MESA 6	1	
NS	109560	INSULATION,TANK, MESA 9	1	
NS	100453	INSULATION,TANK, MESA 14	1	
NS	931074	TAPE,INSULATION	AR	
5	1078999	MANIFOLD ASSY,MESA	1	A
6	940281	O RING,VITON, 1.375X1.500X.063	2	
7	288023	SCREW,SPL,HEX HD,M8-1.25	5	
8	983414	WASHER,FLT,M,NARROW,M8,STL,ZN	5	
9	288022	VALVE,RELIEF,1600 PSI,3.50 LG	1	
10	900344	LUBRICANT,NEVER SEEZ,8OZ CAN	AR	
11	900223	LUBRICANT,O RING,PARKER,4 OZ,30122-5	AR	
NS	288305	INSULATION,TANK,HOSE END (M14 ONLY)	1	

NOTE A: Refer to *Manifold Parts*.
 AR: As Required
 NS: Not Shown

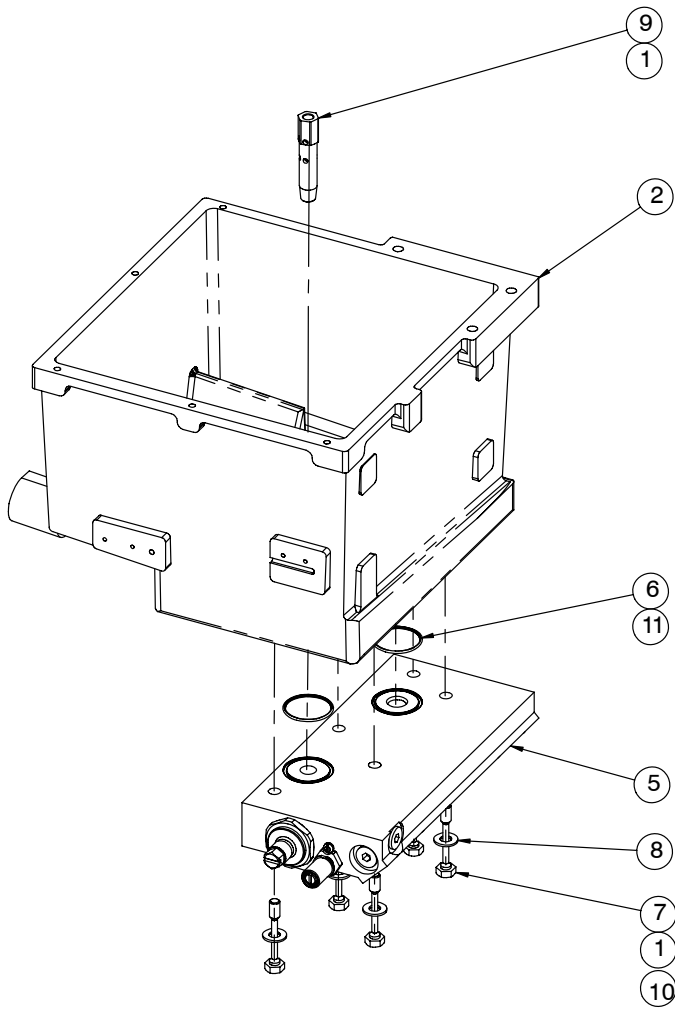

Figure 7-19 Tank/manifold parts, 200–240V or 400/230 Y

Tank/Manifold Parts, 400/480V Delta

See Figure 7-20.

Item	Part	Description	Quantity	Note
1	90034	LUBRICANT,NEVER SEEZ,8OZ CAN	0	
2	117320	TANK,MACHINED, MESA 4	1	
	117321	TANK,MACHINED, MESA 6	1	
	117322	TANK,MACHINED, MESA 9	1	
NS	144869	INSULATION,TANK, MESA 4	1	
NS	144313	INSULATION,TANK, MESA 6	1	
NS	144312	INSULATION,TANK, MESA 9	1	
NS	931074	TAPE,INSULATION	0	
5	1078999	MANIFOLD ASSY,MESA	1	A
6	940281	O RING,VITON, 1.375X1.500X.063	2	
7	288023	SCREW,SPL,HEX HD,M8-1.25	5	
8	983414	WASHER,FLT,M,NARROW,M8,STL,ZN	5	
9	288022	VALVE,RELIEF,1600 PSI,3.50 LG	1	
10	900344	LUBRICANT,NEVER SEEZ,8OZ CAN	0	
11	900223	LUBRICANT,O RING,PARKER,4 OZ,30122-5	0	
12	237797	INSULATOR,HEATER,CERAMIC,M5	4	
13	238857	NUT,SPECIAL,10-32,55	8	
14	238858	WASHER,SPL,10,SS	8	
16	900445	SEALANT,RTV,WHITE,2.8 OZ. TUBE	0	

NOTE A: Refer to *Manifold Parts*.
 AR: As Required
 NS: Not Shown

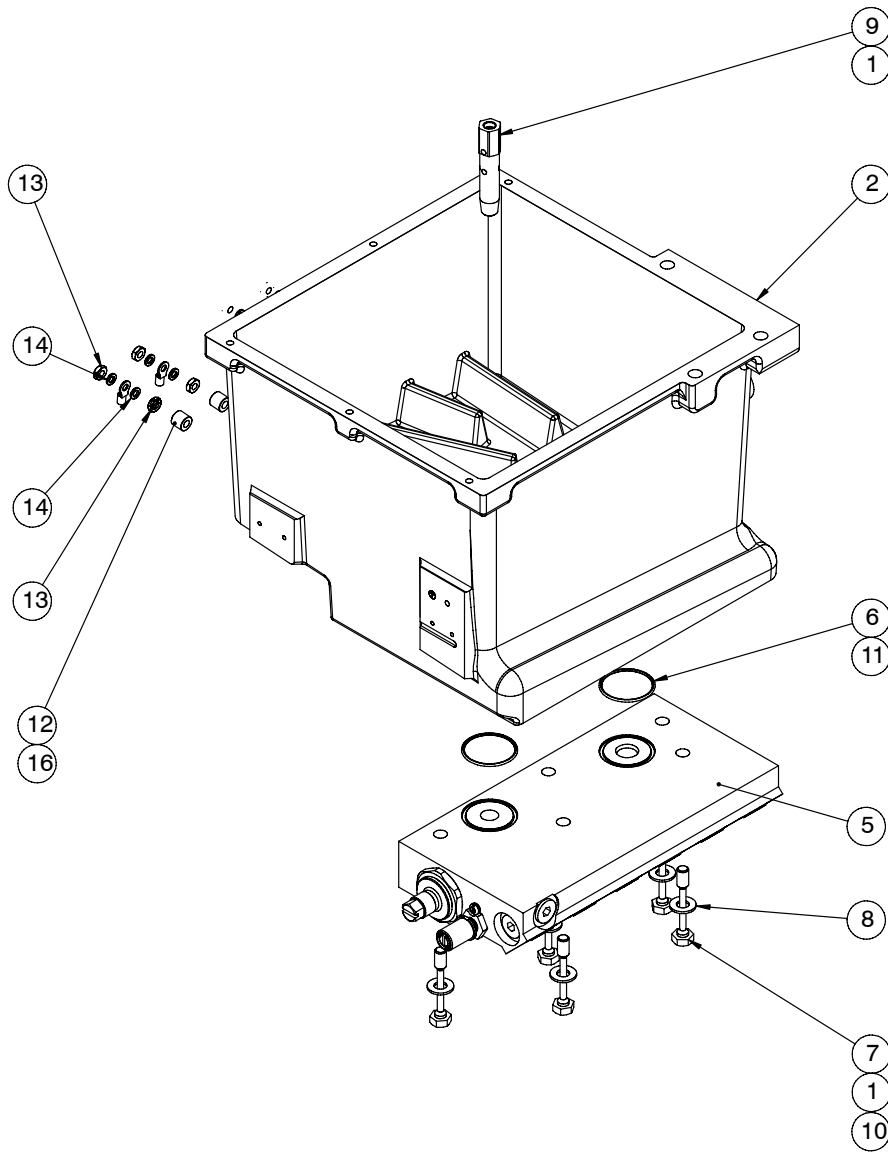

Figure 7-20 Tank/manifold parts, 400/480V Delta

Manifold Parts

See Figure 7-21.

Item	Part	Description	Quantity	Note
1	1078921	MANIFOLD,6-HOSE,MESA	1	
2	973574	PLUG,O RING,STR THD,9/16-18	10	
3	-----	FILTER BUNG ASSY	1	A
4	276024	VALVE ASSY,DRAIN	1	
4A	954036	• BACK-UP RING,SINGLE,1/4 X 3/8	1	
4B	940101	• O RING,VITON,.239ID X .070W,BR	1	
5	274569	ADAPTER,FILTER BUNG	1	
6	941220	O RING,VITON, 1.125X1.313X.094	1	
7	982096	SCR,PAN,SLT,M4X8,ZN	1	
8	983403	WASHER,LK,M,SPT,M4,STL,ZN	1	
9	900344	LUBRICANT,NEVER SEEZ,8OZ CAN	AR	
10	900419	ADHESIVE,LOCTITE 620,GREEN,HI TEMP,50ML	AR	

NOTE A: Refer to *Manifold Filter Parts*.

AR: As Required

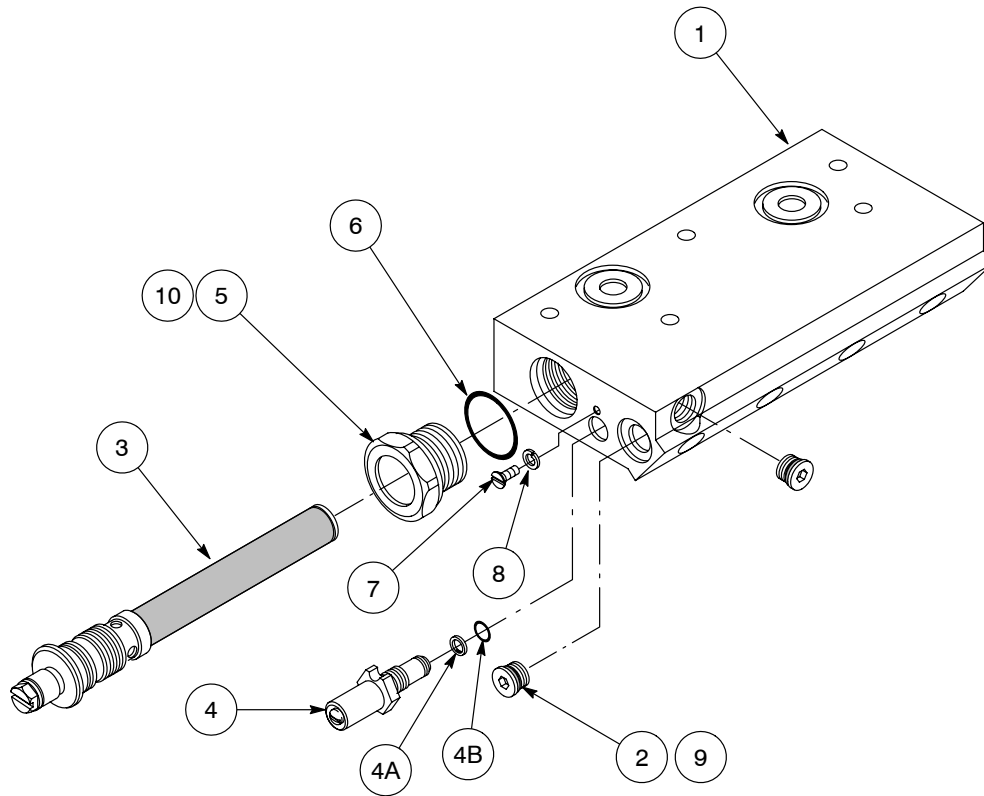

Figure 7-21 Manifold parts

Manifold Filter Parts

See Figure 7-22.

Item	Part	Description	Quantity	Note
—	105432	Service kit, manifold filter	—	A
1	274578	• Screen, filter, 0.006 mesh, 5.38 in. long	1	
2	981747	• Screw, round, 10-32 x 6.250 in.	1	B
3	274513	• Bung, filter	1	
4	941172	• O-ring, Viton, 0.813 x 1.000 x 0.094 in.	1	
5	274579	• Core, filter, 5.718 in. long	1	

NOTE A: Order this part for a complete filter assembly.
B: Apply anti-seize lubricant, part 900341.

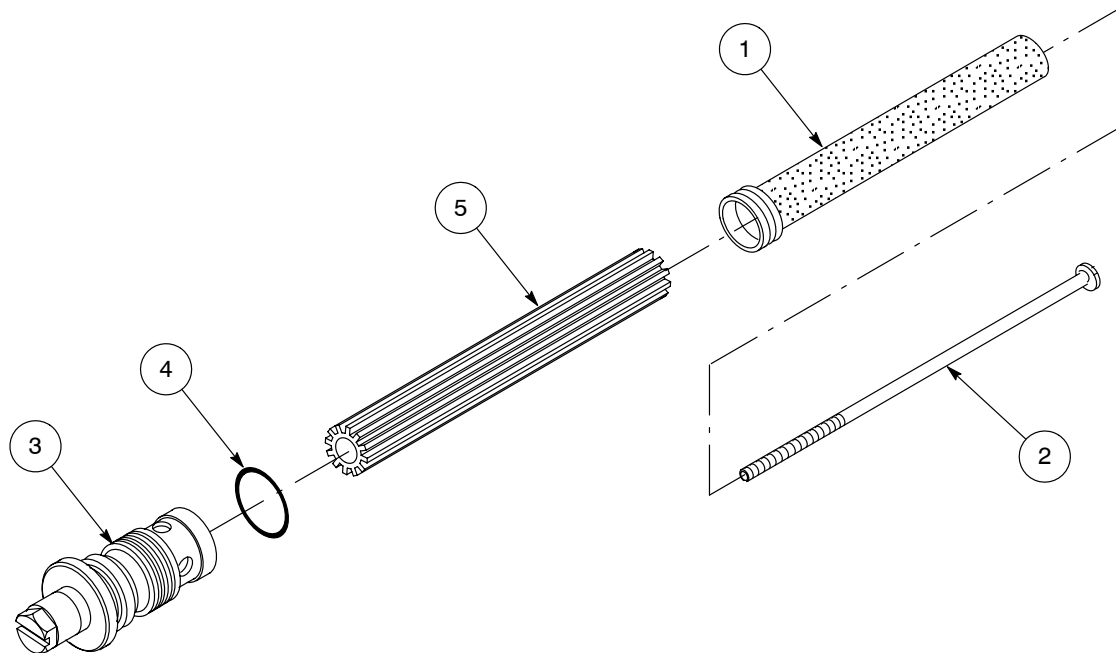

Figure 7-22 Manifold filter parts

Pump Assembly

The pump assembly parts vary depending on the configuration of the melter. Refer to the appropriate parts list for your melter. To determine the configuration of your melter, refer to *Melter Assembly Part Numbers* at the beginning of this section.

14:1 Pump UpTime Pack Parts

See Figure 7-23. The UpTime pack for 14:1 pumps provides the parts that should be replaced as part of routine maintenance.

Item	Part	Description	Quantity	Note
—	164601	Service kit, pump, 14:1 SP, Uptime Pack	—	
2	940332	• O-ring, Viton, 2.00 x 2.125 x 0.063 in.	2	
3	984092	• Nut, hex, lock, torque, M6, class 10	1	
4	163039	• Cup, piston	2	
5	986331	• Retaining ring, internal, 100, push-on	1	
6	952100	• Cup, U, Viton	1	
7	986602	• Retaining ring, internal, 81, inverted	1	
8	273138	• Washer, 0.799 OD x 0.543 ID x 0.034 in.	1	
9	273139	• Seal, pump	1	
10	940133	• O-ring, Viton, 0.426 ID x 0.70 in.	1	
11	940181	• O-ring, Viton, 0.0.739 ID x 0.70 in. wide	4	
NS	211228	• Lubricating oil, SP	1	
NS: Not Shown				

upTIME™

Pack P/N 164601

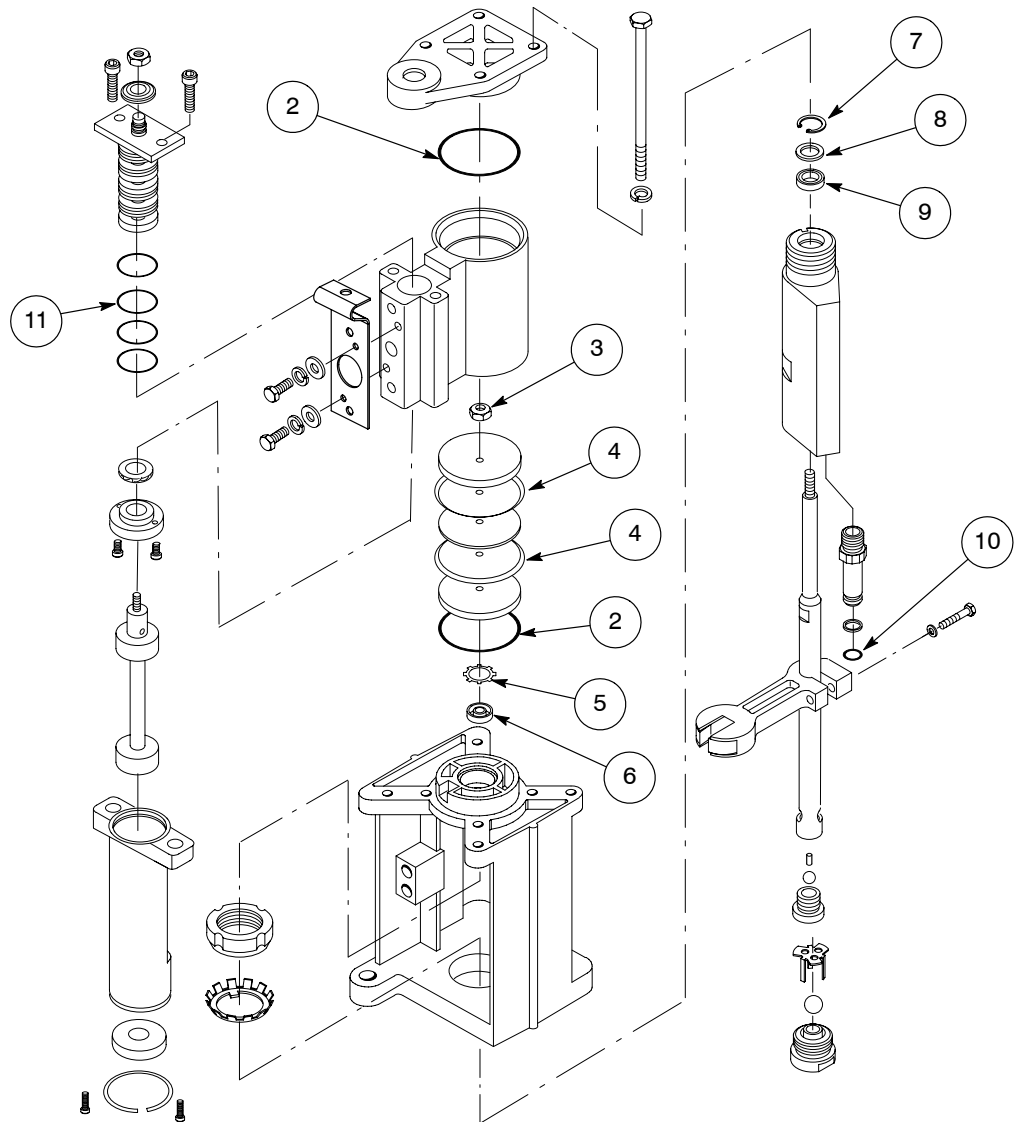

Figure 7-23 14:1 dual-acting pump UpTime Pack parts

14:1 Pump Parts

See Figure 7-24.

Item	Part	Description	Quantity	Note
—	1085001	Kit, pump, piston, dual-acting, 14:1, SP, UpTime Plus	—	A
1	1081854	• Bracket, pump cover	1	
2	982059	• Screw, socket, M4 x 8	2	
3	983402	• Washer, flat, narrow, M4	2	
4	983403	• Washer, lock, split, M4	2	
5	1006027	• Valve, SP	1	
6	900493	• Lubricant, Parker, hi-temp	AR	
7	333560	• Spring, wave, SP pump	1	
8	155057	• Detent, upper, SP	1	
9	166880	• Fork, magnetic	1	
10	164606	• Actuator, magnetic, SP	1	
11	155068	• Can, SP	1	
12	155067	• Detent, lower, SP	1	
13	986714	• Retaining ring, internal, 156, bowed	1	
14	155059	• Piston pump, 14:1, SP	1	
15	985302	• Pin, roll, 0.125 x 0.500 in.	1	
16	900000	• Ball, 440 stainless, 0.375 in., 50	1	
17	503709	• Seat, ball, pressure	1	
18	900470	• Adhesive, threadlocking, Loctite 272	AR	
19	503696	• Cage, ball, siphon	1	
20	105451	• Kit, tube, crossover, pump (includes items 20, 22, and 23)	1	
21	900344	• Lubricant, Never Seez, 8 oz can	AR	
22	954013	• Backup ring, single, $\frac{7}{16} \times \frac{9}{16}$ in.	1	
23	940133	• O-ring, Viton, 0.426 ID x 0.070 in. wide	1	
24	503695	• Seat, ball, siphon	1	
25	900001	• Ball, 440 stainless, 0.500 in., 50	1	
26	288028	• Body, pump, hydraulic	1	
27	973402	• Plug, pipe, socket, flush, $\frac{1}{8}$ in.	1	
28	120599	• Kit, pump mount, machined (includes items 28, 29, 30, 33, 34, and 35)	1	
29	983184	• Washer, lock, bearing, W-08,	1	
30	984545	• Nut, lock, bearing, PN-08	1	
31	982135	• Screw, hex, cap, M6 x 30	1	
32	983410	• Washer, flat, narrow, M6	1	
33	940332	• O-ring, Viton, 2.000 x 2.125 x 0.063 in.	2	
34	952100	• U-cup, Viton	1	
35	986331	• Retaining ring, internal, 100, push-on	1	
36	309822	• Manifold, air, SP	1	
37	984092	• Nut, hex, lock, torque, M6, class 10	1	
38	333137	• Head, cylinder, SP, machined	1	
39	983445	• Washer, piston seal, SP	1	
40	983446	• Washer, piston cup, SP	2	
41	163039	• Cup, piston, SP	2	
42	986602	• Retaining ring, internal, inverted	1	
43	273138	• Washer, 0.799 OD x 0.543 ID x 0.034 in. thick	1	

Continued on next page

Item	Part	Description	Quantity	Note
44	273139	• Seal, pump	1	
45	982147	• Screw, hex, cap, M6 x 120	4	
46	983409	• Washer, lock, split, M6	4	
47	982028	• Screw, socket, M5 x 20	4	
48	211228	• SP lubricating oil	AR	
49	988508	• Screw, socket, M4 x 8	2	
50	1082730	• SPCLNUT, Spring Type, U, M5	1	

NOTE A: For a complete pump, order this part number.

AR: As Required

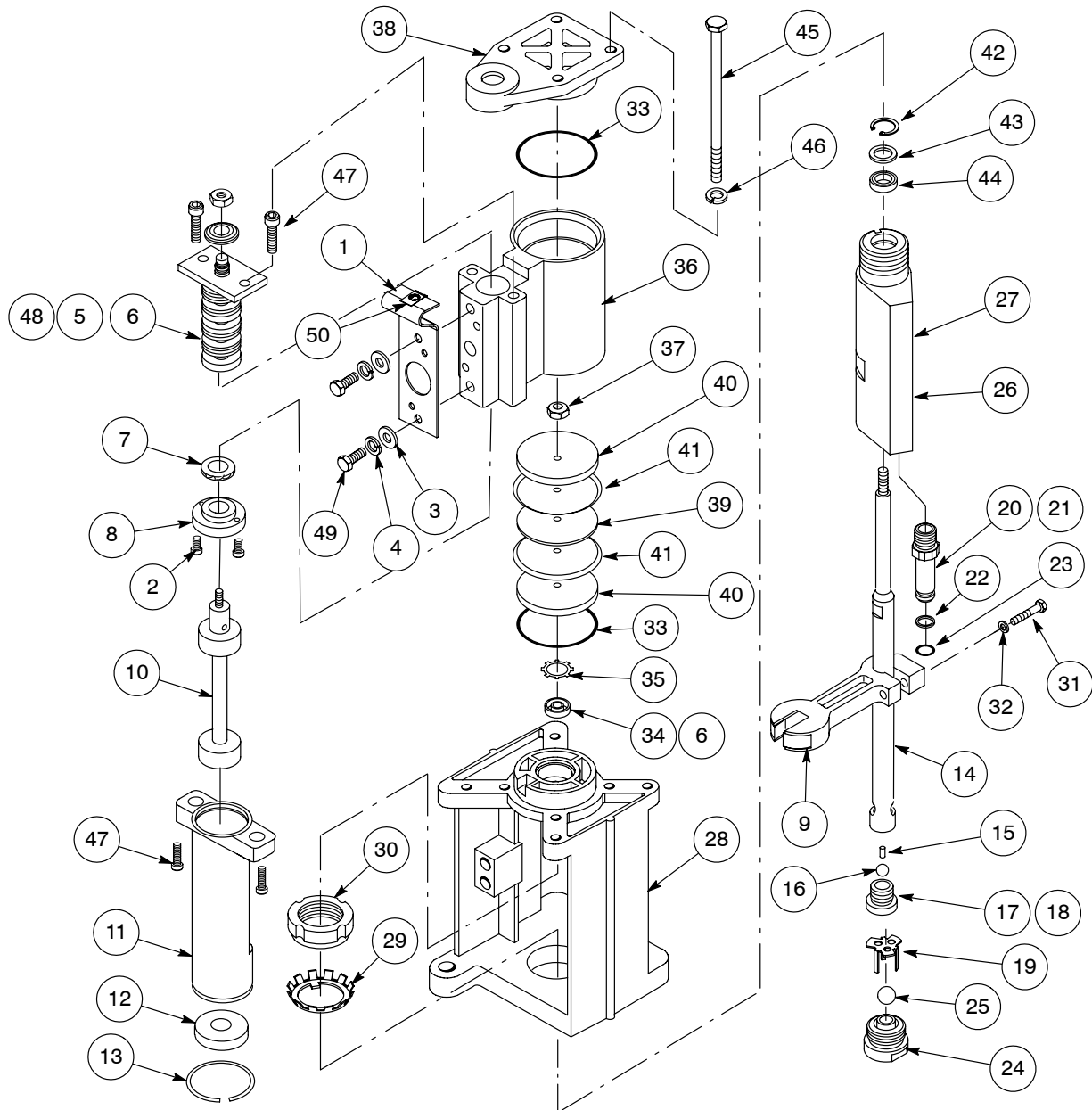

Figure 7-24 14:1 dual-acting pump parts

21:1 Pump and Actuator Parts

See Figure 7-25.

Item	Part	Description	Quantity	Note
—	-----	PUMP,PISTON,21:1,MESA,W/ACT.	—	A
1	-----	• PUMP,W/O ACTUATOR,21:1,MESA	1	A, B
2	-----	• ACTUATOR ASSY,SP	1	C
3	164550	• FORK ASSY,SP 21	1	
4	982135	• SCR,HEX,CAP,M6X30,ZN	1	
5	982298	• SCR,HEX,CAP,M5X50,BL	2	
6	983410	• WASHER,FLT,M,NARROW,M6,STL,ZN	1	
7	983408	• WASHER,FLT,M,NARROW,M5,STL,ZN	2	
8	940111	• O RING,VITON,.301ID X .070W,BR, 10411 SB	4	
10	1083644	• BRACKET,PUMP COVER,MESA 14,21:1	1	
11	1082730	• SPCLNUT, Spring Type,U,M5	1	

NOTE A: Refer to *Recommended Spare Parts* for pump service kit numbers.

B: Refer to *21:1 Pump Parts*.

C: Refer to *21:1 Pump Actuator Parts*.

AR: As Required

NS: Not Shown

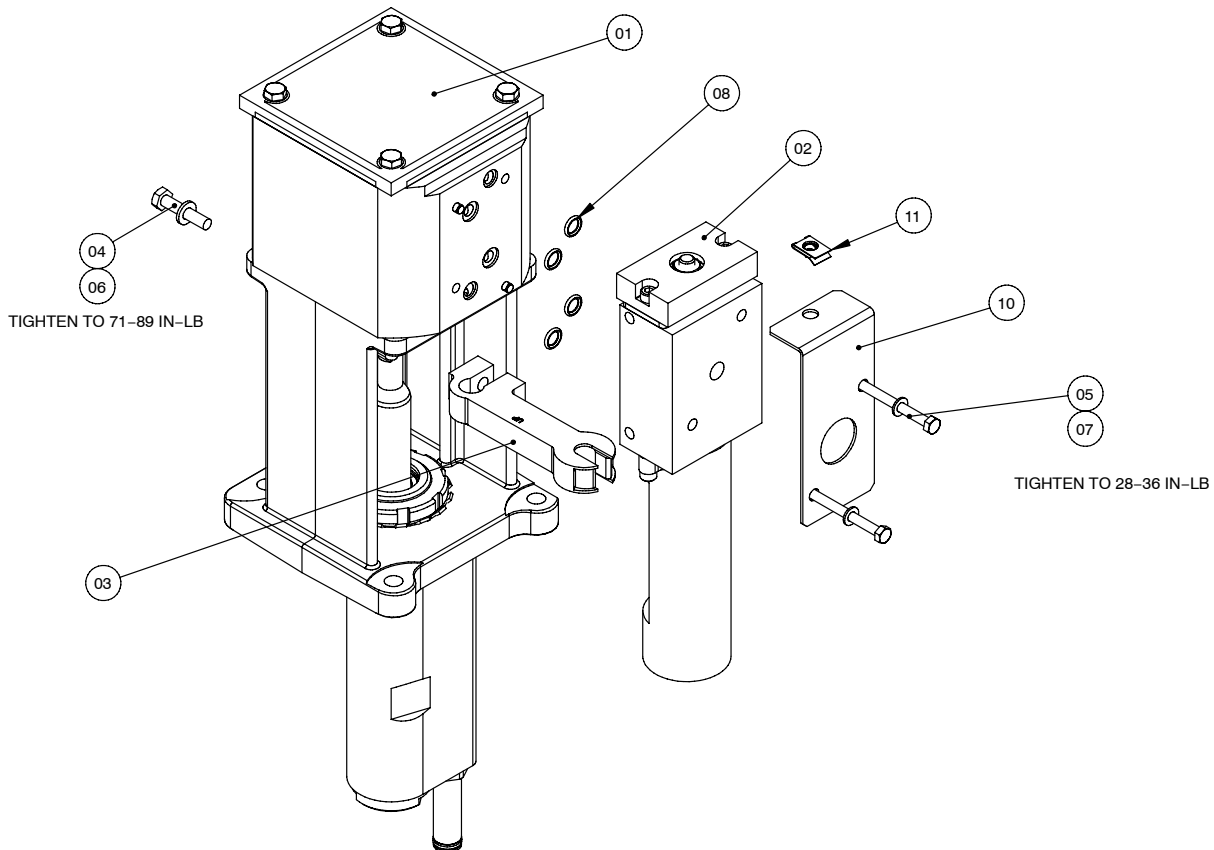

Figure 7-25 21:1 pump and actuator parts

This page intentionally left blank.

21:1 Pump Parts

See Figure 7-26.

Item	Part	Description	Quantity	Note
—	-----	PUMP,W/O ACTUATOR,21:1,MESA	—	A
1	134657	• BODY,PISTON PUMP,21:1,GRID	1	
2	161203	• MOUNT,21/1 SP PUMP,MACH'D	1	
3	161204	• CYLINDER,AIR,21/1 SP PUMP	1	
4	1062892	• PISTON ASSY,HYD,21:1,IMPROVED	1	
5	1081497	• CAP,AIR CYL,SP-30,21:1PUMP,MESA	1	
6	240533	• CAGE,BALL,SIPHON	1	
7	240534	• SEAT,SIPHON BALL	1	
9	288031	• TUBE,CROSSOVER,MPL PUMP	1	
10	288115	• WASHER,PISTON,CUP,HI VOL,	2	
11	288116	• CUP,PISTON,HI VOLUME,MPL	2	
12	288117	• WASHER,PISTON SEAL,HI VOL,MPL	1	
13	288121	• WASHER,1.045X .819	1	
14	288122	• SEAL,PUMP,HI VOL,MPL	1	
15	900023	• BALL,440SSTL, .750, 50	1	
16	900236	• SEALANT,PASTE,TEFLON	AR	
17	900344	• LUBRICANT,NEVER SEEZ,8OZ CAN	AR	
19	900493	• LUBRICANT,PARKER HI-TEMP,11208	AR	
20	940133	• O RING,VITON,.426ID X .070W,BR,10413	1	
21	940440	• O RING,VITON, 3.750X3.875X.063	2	
22	941261	• O RING,VITON, 1.375X1.563X.094	1	
23	952100	• CUP,U,VITON	1	
24	954013	• BACK-UP RING,SINGLE,7/16X9/16	1	
25	973402	• PLUG,PIPE,SKT,FLUSH,1/8,ZN	1	
26	973466	• PLUG,PIPE,FLUSH,1/16 W/SEALANT	2	
27	982147	• SCR,HEX,CAP,M6X120,ZN	4	
30	983134	• WASHER,LK,E,BRG,1.574,STL,ZN	1	
31	983409	• WASHER,LK,M,SPT,M6,STL,ZN	4	
32	1064157	• NUT,HEX,LOCK,TORQUE,M6X1, DIN 980V,V3	1	
33	984545	• NUT,LOCK,BRG,PN-08,STL,ZN	1	
34	986331	• RETAINING RING,INT,100,PUSHON	1	
35	986711	• RETAINING RING,INT,106,SPIRAL	1	

NOTE A: Refer to *Recommended Spare Parts* for pump service kit numbers.

AR: As Required

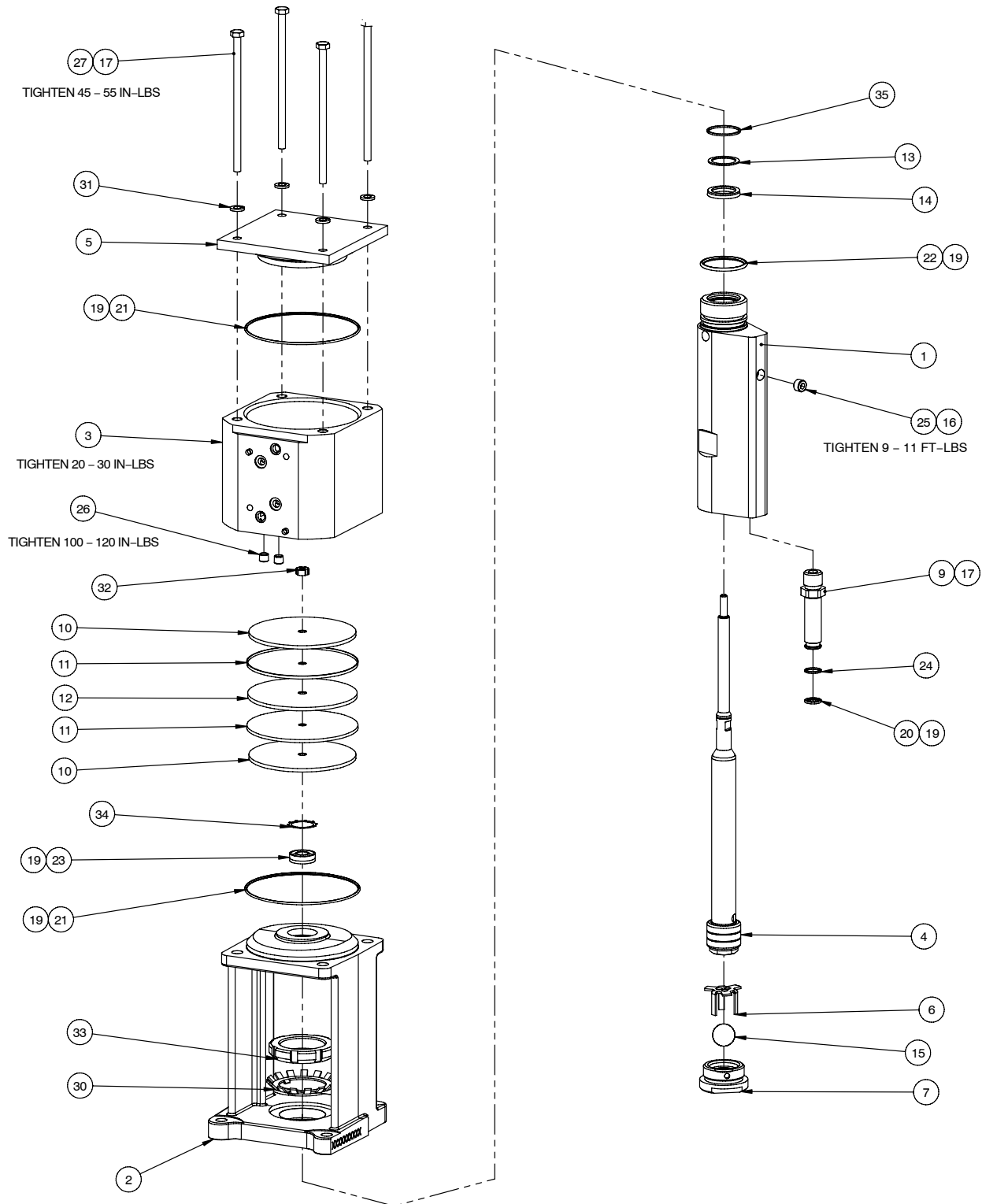

Figure 7-26 21:1 pump parts

21:1 Pump Actuator Parts

See Figure 7-27.

NOTE: A 21:1 dual-acting pump is air-actuated by an actuator. A 10:1 single-acting pump is air-actuated by a triggering solenoid valve.

Item	Part	Description	Quantity	Note
—	155077	SERVICE KIT, ACTUATOR ASSY,SP	—	
1	155051	• BODY,VALVE,SP	1	
2	155054	• CAP,VALVE,SP	1	
3	-----	• VALVE ASSY SP	1	A
4	155057	• DETENT,UPPER,SP	1	
5	155067	• DETENT,LOWER ,SP	1	
6	155068	• CAN,SP	1	
7	333560	• SPRING,WAVE,INCONEL,SP PUMP	1	
8	-----	• ACTUATOR,MAGNETIC,ASSY,SP	1	B
10	211228	• SERVICE KIT,SP LUBRICATING OIL	AR	
12	982028	• SCR,SKT,M5X20,BL	4	
13	982059	• SCR,SKT,M4X8,BL	2	
15	986714	• RETAINING RING,INT,156,BOWED	1	
<p>NOTE A: For this part, order service kit P/N 1006027. For a kit that includes only the bumper assembly, order service kit P/N 1014650.</p> <p>B: For this part, order service kit P/N 164606.</p> <p>AR: As Required</p>				

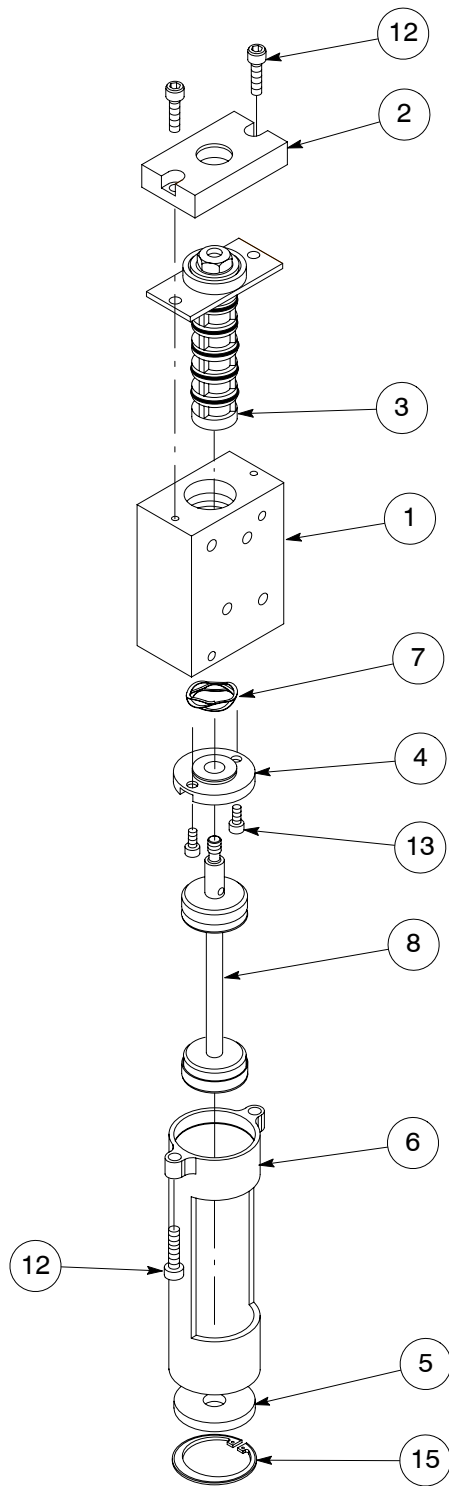

Figure 7-27 21:1 pump actuator parts

10:1 Pump and Solenoid Parts

See Figure 7-28.

NOTE: A 21:1 dual-acting pump is air-actuated by an actuator. A 10:1 single-acting pump is air-actuated by a triggering solenoid valve.

Item	Part	Description	Quantity	Note
1	1084449	Service kit, pump, piston, single-acting, 10:1, with solenoid valve	1	A
NS	1084450	Service kit, pump, piston, single-acting, 10:1, without solenoid valve	1	B
—	138163	Service kit, check valve and ball	—	
2	102324	• Seat, ball check valve	1	
3	900000	• Ball, 440 stainless steel, 0.375 in., 50	1	
—	105451	Service kit, crossover tube, backup ring, and O-ring	—	
4	-----	• Tube, crossover	1	
5	954013	• Backup ring, single, $\frac{7}{16} \times \frac{9}{16}$ in.	1	
6	940133	• O-ring, Viton, 0.426 in. ID x 0.70 in. wide	1	
—	138177	Service kit, siphon ball, seat, and cage	—	
7	240533	• Cage, ball, siphon	1	
8	900023	• Ball, 440 stainless steel, 0.750 in., 50	1	
9	240534	• Seat, siphon ball	1	
NS	1011323	Service kit, air cylinder (includes special tool)	1	
10	1084561	Service kit, solenoid valve, 10:1 pump	1	
NOTE	<p>A: For a complete pump and solenoid valve assembly, order this part. For a solenoid valve only, order part 1084561.</p> <p>B: For a complete pump only (without the solenoid valve), order this part.</p> <p>NS: Not Shown</p>			

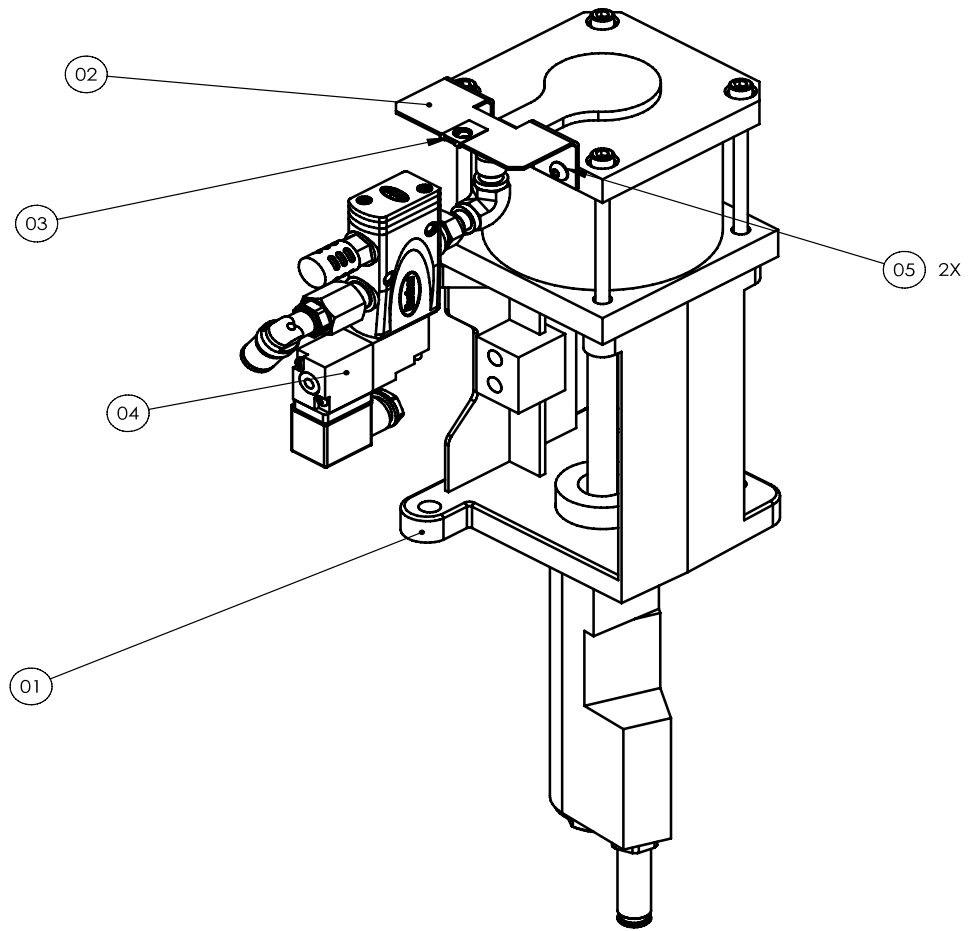

Figure 7-28 10:1 pump parts

Left Cover Assembly

The left cover assembly parts vary depending on the configuration of the melter. Refer to the appropriate parts list for your melter. To determine the configuration of your melter, refer to *Melter Assembly Part Numbers* at the beginning of this section.

Left Cover Parts, Two Hose/Gun Melters

See Figure 7-29.

Item	Part	Description	Quantity	Note
1	-----	PANEL, LEFT, MESA	1	
2	240674	TAG, GROUND	1	
3	1023299	LUG, 45, SINGLE, M5 X .032	1	
4	983401	WASHER, LK, M, SPT, M5, STL, ZN	1	
5	984706	NUT, HEX, M5, STL, ZN	1	
7	-----	INSULATION, PANEL, RT AND LT, MESA 4	1	
8	1025326	TAG, CAUTION, HOT SURFACE, 1.19X6.544	1	
NOTE A: Refer to <i>Recommended Spare Parts</i> for the part number of this item.				

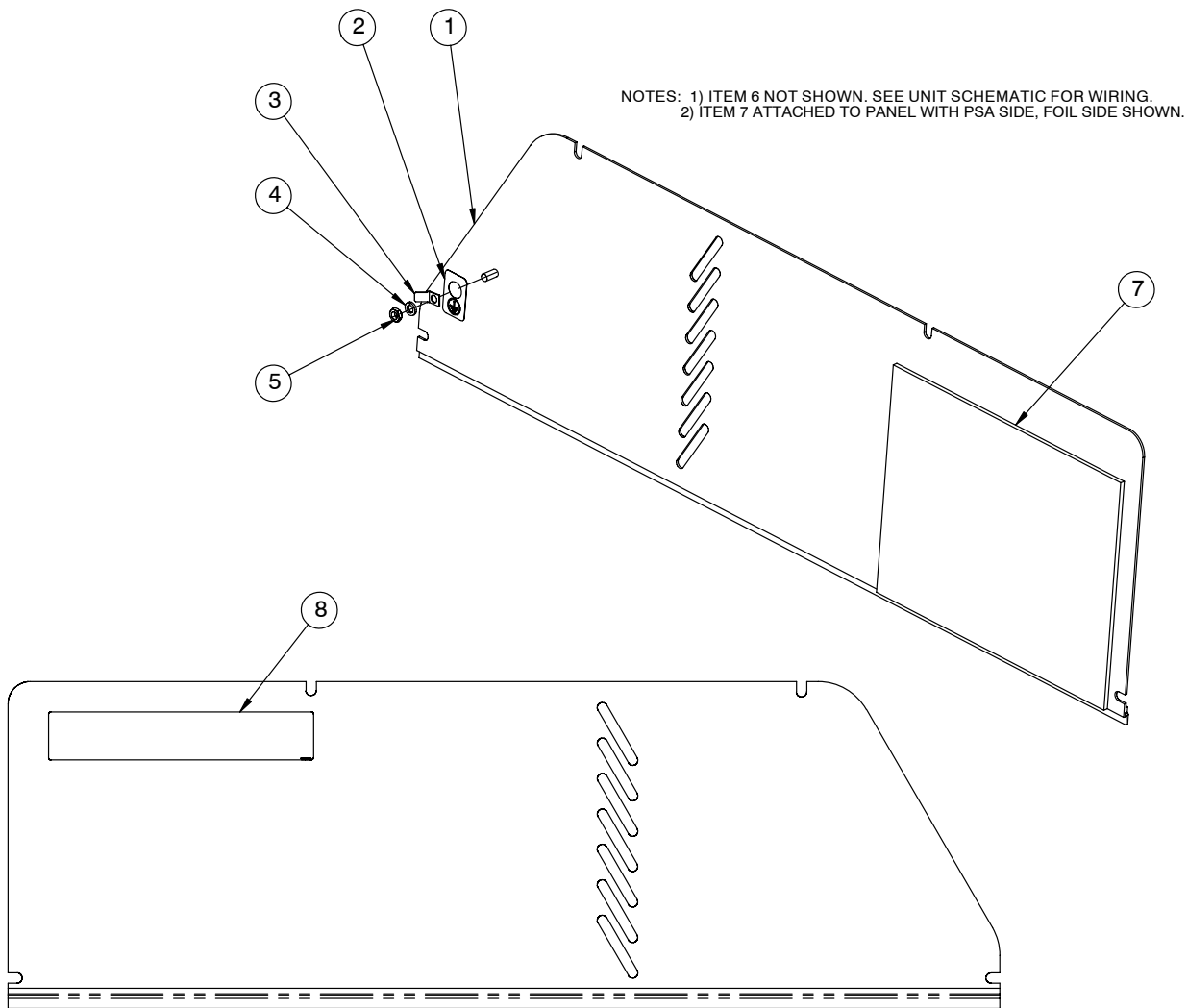

Figure 7-29 Left cover parts, two hose/gun melters

Left Cover Parts, Four/Six Hose/Gun Melters

See Figure 7-30.

Item	Part	Description	Quantity	Note
1	-----	PANEL,LEFT,MESA	1	
2	1078925	BRACKET,POWER MOD., MESA	1	
3	1040011	NUT,HEX W/EXT TOOTH WASHER,M4	8	
4	101844	GROMMET,EXTRUDED,.06 X .44	0.86	
5	-----	PCA,PWR MOD,4CH,240V,MS/US/AS	1	A
6	163024	COVER,FUSE,5X20MM	4	
10	-----	INSULATION,PANEL,RT AND LT	1	
11	1025326	TAG,CAUTION,HOT SURFACE,1.19X6.544	1	
12	1090004	GASKET,PWR.MDL,MESA 4/6 HOSE	1	

NOTE A: Refer to *Recommended Spare Parts* for the part number of this item.

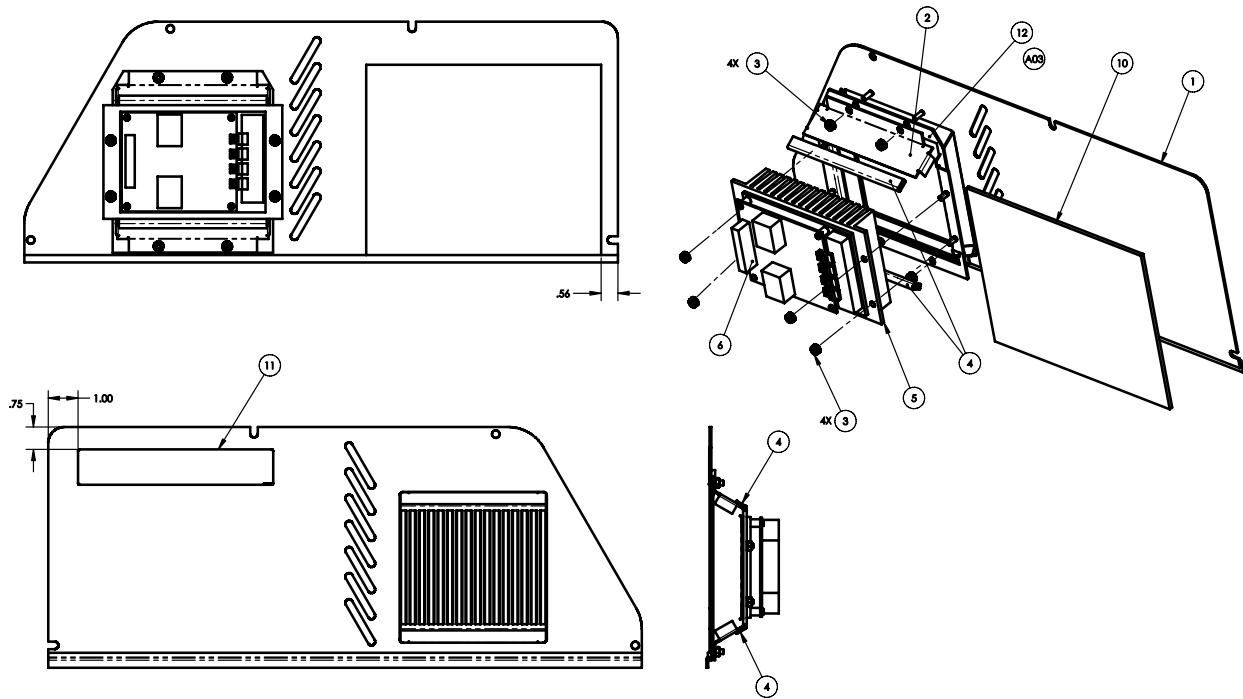

Figure 7-30 Left cover parts, four/six hose/gun melters

Left Cover Parts, Two Hose/Gun MESA 4

See Figure 7-30.

Item	Part	Description	Quantity	Note
1	1088558	PANEL,LEFT,MESA 4,2H	1	
2	240674	TAG,GROUND	1	
3	1023299	LUG,45,SINGLE,M5 X .032	1	
4	983401	WASHER,LK,M,SPT,M5,STL,ZN	1	
5	984706	NUT,HEX,M5,STL,ZN	1	
7	1082670	INSULATION,PANEL,RT AND LT,MESA 4	1	
8	1025326	TAG,CAUTION,HOT SURFACE,1.19X6.544	1	

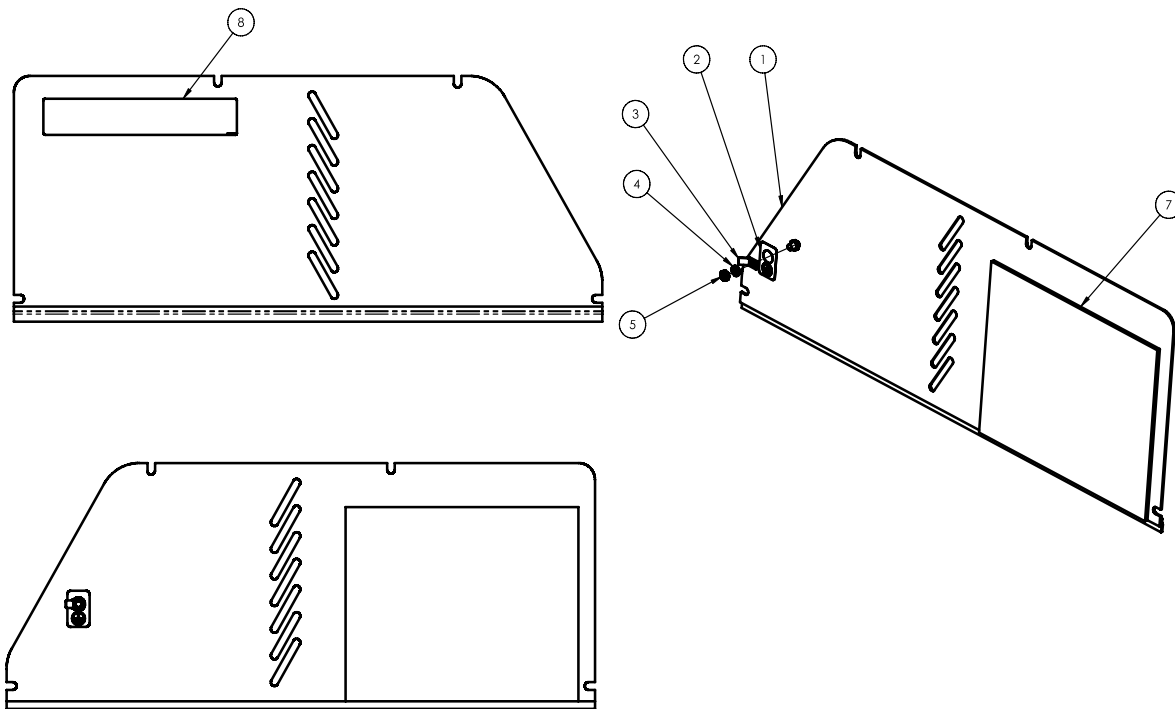

Figure 7-31 Left cover parts, two hose/gun MESA 4

Right Cover Assembly

Right Cover Parts, Two/Four Hose/Gun MESA 4

See Figure 7-30.

Item	Part	Description	Quantity	Note
1	1088586	PANEL, RIGHT, MESA 4, 2H, 4H	1	
2	240674	TAG, GROUND	1	
3	1023299	LUG, 45, SINGLE, M5 X .032	1	
4	983401	WASHER, LK, M, SPT, M5, STL, ZN	1	
5	984706	NUT, HEX, M5, STL, ZN	1	
7	1082670	INSULATION, PANEL, RT AND LT, MESA 4	1	
8	1025326	TAG, CAUTION, HOT SURFACE, 1.19X6.544	1	

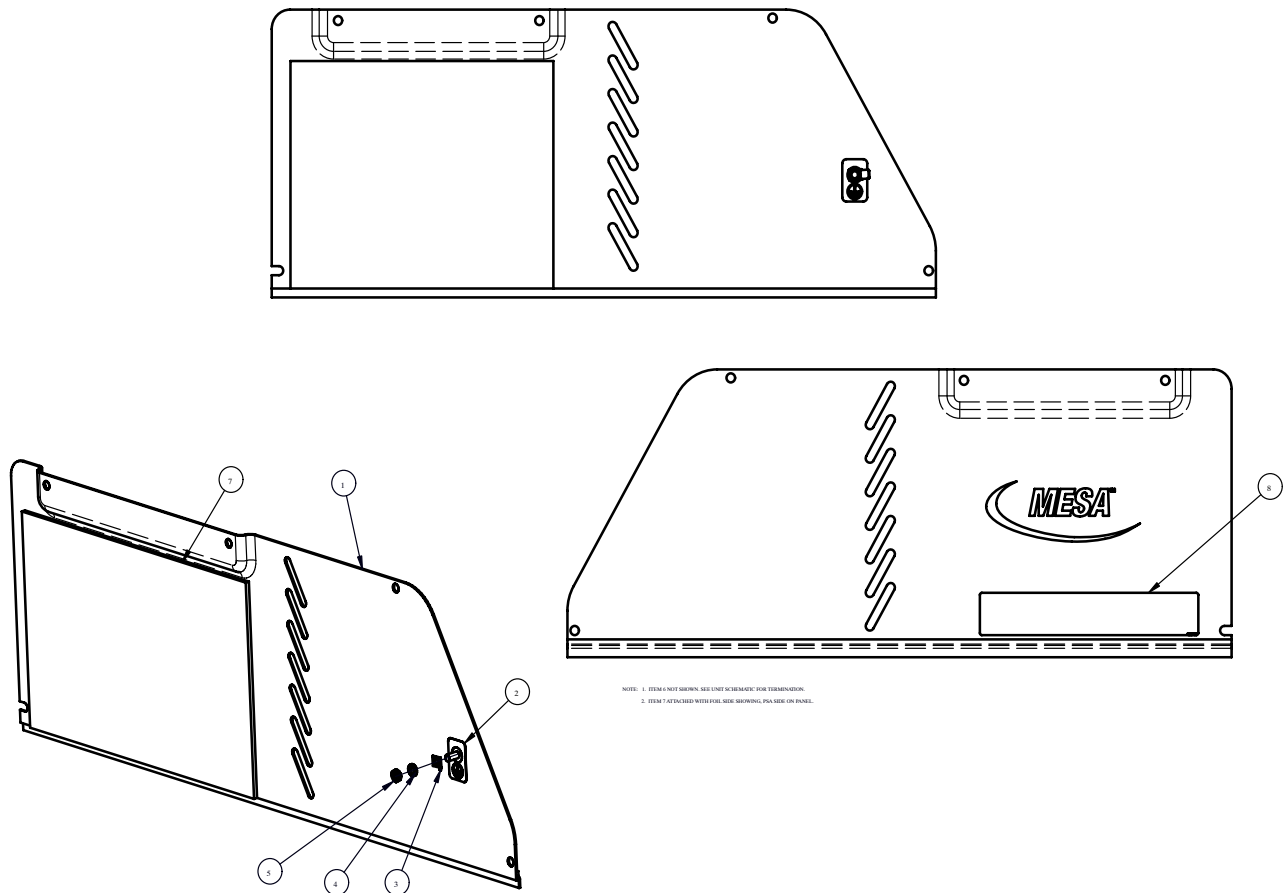

Figure 7-32 Right cover parts, two/four hose/gun MESA 4

Right Cover Assembly, M14, 6 H/G

See Figure 7-33.

Item	Part	Description	Quantity	Note
1	-----	• PANEL,RIGHT,MESA 14,6H	1	
2	1078925	• BRACKET,POWER MOD., MESA	1	
3	1040011	• NUT,HEX W/EXT TOOTH WASHER,M4	8	
4	101844	• GROMMET,EXTRUDED,.06 X .44	0.86	
5	-----	• PCA,PWR MOD,4CH,240V,MS/US/AS	1	A
6	163024	• COVER,FUSE,5X20MM	4	
10	1083632	• INSULATION,PANEL RT. AND LF.,MESA 14	1	
	1082670	• INSULATION,PANEL,RT AND LT,MESA 4	1	
11	1025326	• TAG,CAUTION,HOT SURFACE,1.19X6.544	1	
12	1090004	• GASKET,PWR.MDL,MESA 4/6 HOSE	1	

NOTE A: Refer to *Recommended Spare Parts* for the part number of this item.

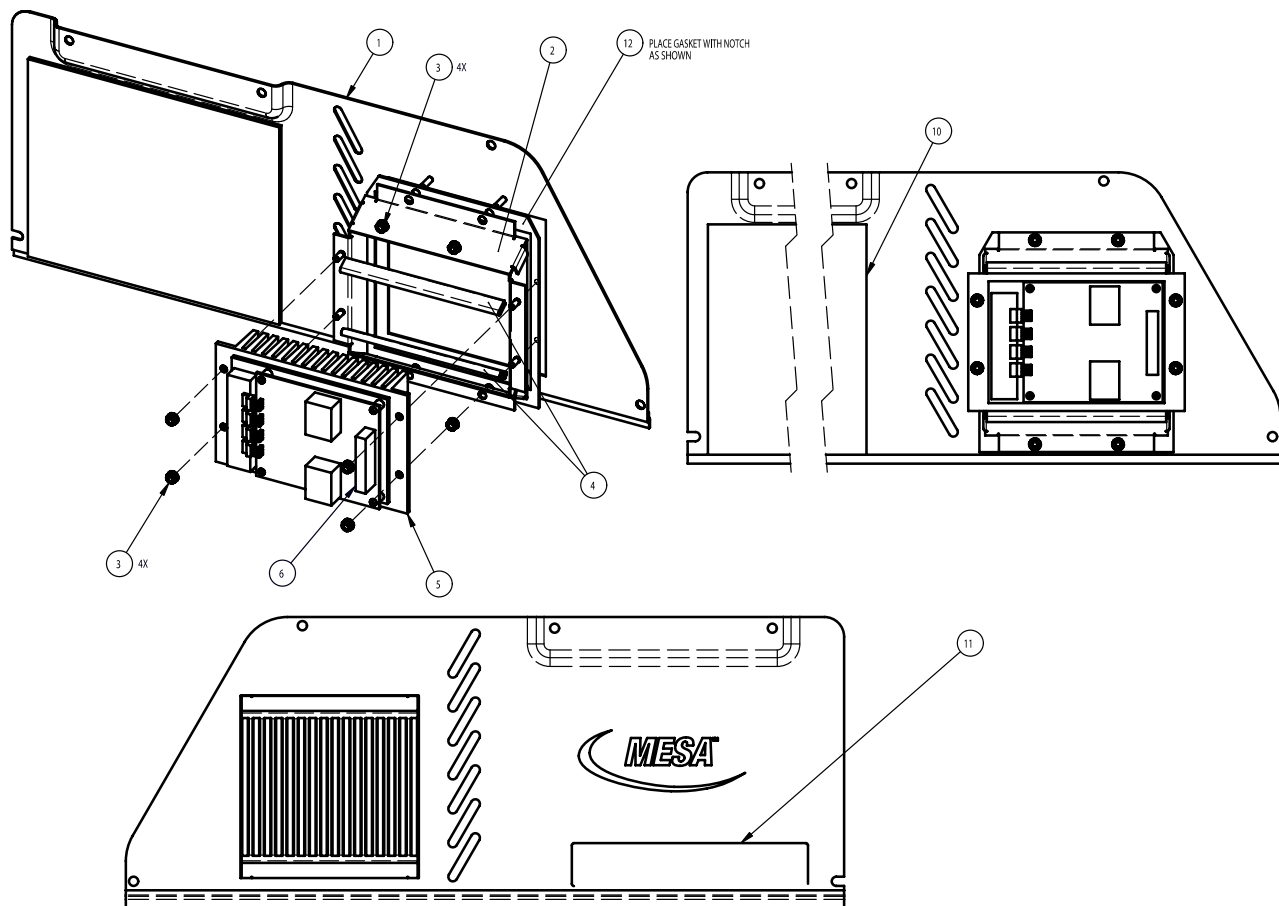

Figure 7-33 Right cover parts, M14, six hose/gun melters

Tank Cover Assembly

See Figure 7-34.

Item	Part	Description	Quantity	Note
1	1089054	PANEL,LID&PUMP CVR,SUPT.,MESA 4	1	
—	1089055	PANEL,LID&PUMP CVR,SUPT.,MESA 6	—	
—	1089056	PANEL,LID&PUMP CVR,SUPT.,MESA 9		
—	1089057	PANEL,LID&PUMP CVR,SUPT.,MESA 14		
2	143653	SCR,HILO,PAN,REC,CUT,6-19X.50	2	
3	1084782	CAP,FRONT,SUPPORT,TANK COVER	1	
4	1084776	CAP,REAR,SUPPORT,TANK COVER	1	

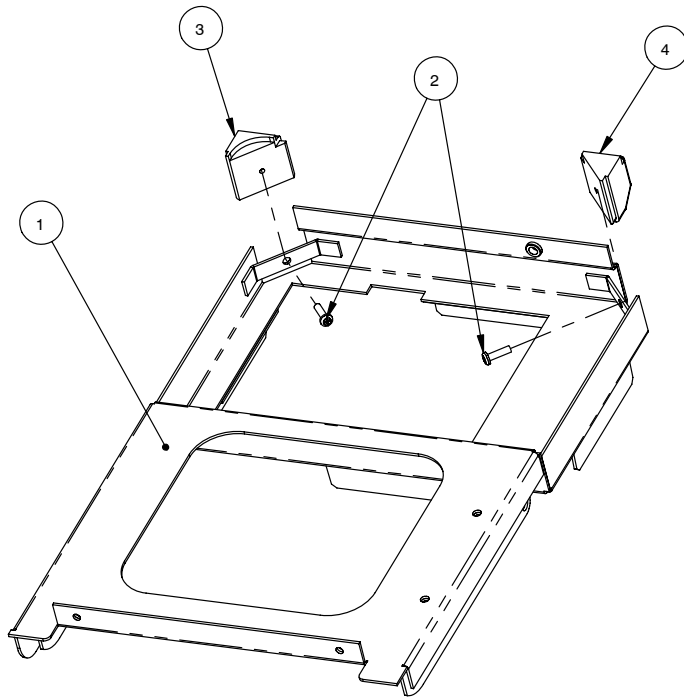

Figure 7-34 Tank cover assembly

This page intentionally left blank.

Front Panel Assembly

See Figure 7-35.

Item	Part	Description	Quantity	Note
1	1079036	PANEL ASSY.,FRONT,W/TAGS	1	
2	1013727	PCA,DISPLAY/CPU,BLUE SERIES	1	
3	1018807	THRDSPCRMM,MALE/FEM,SS,HEX,M3,8MMLG	7	
4	249675	NUT,HEX,M3,W/EXT TOOTH,WSHR	6	
5	208498	LATCH, SPRING, MED, 4MM HEX HD	3	
6	240674	TAG,GROUND	1	
7	1023299	LUG,45,SINGLE,M5 X .032	1	
8	984706	NUT,HEX,M5,STL,ZN	1	
9	983401	WASHER,LK,M,SPT,M5,STL,ZN	1	
10	1017947	SWITCH,ROCKER,SPST,250V,16A,GOLD	1	
14	983520	WASHER,LK,M,INT,M3,STL,ZN	7	
15	1023715	THRDSPCRMM,NYLON,F/F, M3 X 6MM HEX x10M	1	
19	940133	O RING,VITON,.426ID X .070W,BR,10413	2	

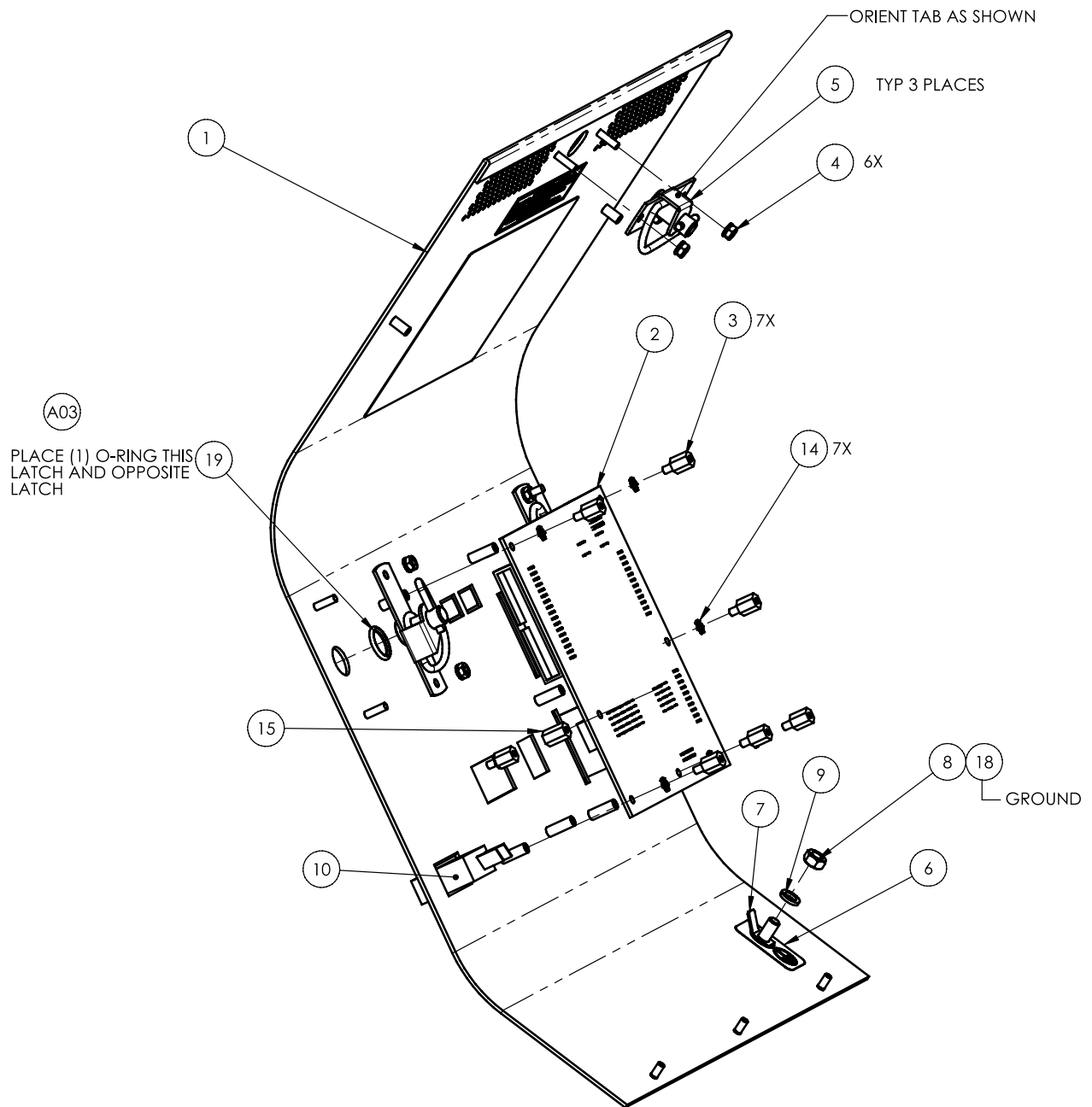

Figure 7-35 Front panel assembly

Melter Wiring

Refer to Section 6, *Troubleshooting*, for melter wiring information and part numbers.

Recommended Spare Parts

Nordson Corporation recommends stocking your spare parts inventory with the following service kits and parts.

Electrical Components (200–240V or 400/230 Y)

Panels and Boards:

Part 1084230 Service kit, front panel
 Part 1084620 Service kit, main board
 Part 1083686 Service kit, display/CPU board
 Part 1092652 Service kit, expansion board, GEN2
 Part 1031202 Service kit, power module

Fuses:

Part 939683 Fuse, 6.3 A (8–12 required)
 Part 939491 Fuse, 25 A (2 required)
 Part 939955 Fuse, 2 A (2 required)

Electrical Components (400/480V Delta)

Panels and Boards:

Part 1084230 Service kit, front panel
 Part 1084620 Service kit, main board
 Part 1083686 Service kit, display/CPU board
 Part 1092652 Service kit, expansion board, GEN2
 Part 1031202 Service kit, power module
 Part 1086169 Service kit, power distribution module, 400/480V Delta
 Part 1086167 Service kit, 1.5 kVA transformer, 400/480V Delta

Fuses:

Part 1086168 Service kit, fuse, 400/480V Delta

Pumps

14:1 Pump:

- Part 1085001 UpTime Plus pack for 14:1 pump
- Part 164601 UpTime pack for 14:1 pump
- Part 1085003 Kit, pump cover bracket, 14:1 pump

21:1 Pump:

- Part 1084444 Service kit, 21:1 pump

10:1 Pump:

- Part 1084449 Service kit, 10:1 pump, with solenoid
- Part 1084450 Service kit, 10:1 pump, without solenoid
- Part 1084561 Service kit, solenoid valve, 10:1 pump

NOTE: The UpTime Plus pack includes a complete pump assembly and the pump cover bracket. The UpTime pack includes pump parts that should be replaced as part of routine maintenance.

Consumables and Wear Items

RTD or Thermostat:

- Part 249800 Thermostat service kit
- Part 108907 RTD service kit

O-Rings:

Manifold:

- Part 105523 Viton O-ring, 1.375 X 1.500 X 0.063 in. (five of 940281)
- Part 105525 Viton O-ring, 1.125 X 1.313 X 0.094 in. (four of 941220)

Filter:

- Part 105524 O-ring for filter assembly (four of 941172)

Pump:

- Part 940332 Viton O-ring, 2.000 x 2.125 x 0.063 in. (14:1)
- Part 940181 Viton O-ring, 0.739 x 0.070 in. (14:1, 21:1)
- Part 940111 Viton O-ring, 0.301 x 0.070 in. (21:1)
- Part 940133 Viton O-ring, 0.426 x 0.070 in. (14:1, 21:1, 10:1)

Continued...

Consumables and Wear Items (contd)

Pump Parts (other than O-rings):	
Part 163039	Cup, piston (14:1)
Part 952100	Cup, U, Viton (14:1, 21:1)
Part 986331	Retaining ring, internal, 100, push-on (14:1, 21:1)
Part 954013	Backup ring, single, $\frac{7}{16} \times \frac{9}{16}$ in. (14:1, 21:1, 10:1)
Part 1006027	Valve assembly, SP (14:1, 21:1)
Part 164606	Actuator assembly, magnetic (14:1, 21:1)
Part 1014650	Kit, bumper assembly, SP valve (14:1, 21:1)
Part 105451	Kit, crossover tube (14:1, 21:1, 10:1)
Part 138163	Kit, check valve and ball (10:1)
Part 138177	Kit, siphon ball and cage (21:1, 10:1)
Part 1011323	Kit, air cylinder (includes special tool) (10:1)
Manifold Filter Screen:	
Part 274578	Filter screen, 0.006-in. mesh
Regulator/Filter Assembly:	
Part 165870	Filter element kit

Supplies and Tools

Part	Item
900236	Teflon paste (for tank seals or NPT threads)
900223	Parker lubricant (for Viton O-rings)
900419	Retaining cylindrical adhesive (for non-removable washers and screws)
900341	Never-Seez lubricant (for removable washers and screws)
211228	Pump lubricating oil (for the air valve on 14:1 pumps)
902514	Protective gloves
901515	Filter for air supply to pump
901915	Nozzle cleaning kit
270755	Type-R fluid
143958	Anti-static ground wrist strap

Section 8

Technical Data

General Specifications

Mesa 4 Melter

Item	Specification	Notes
General		
Weight of Empty Unit	41.1 kg (90.5 lb)	A
Weight of Full Unit	45.1 kg (99.3 lb)	
Hose Ports	4	
Melt Rate	3.6 kg/hr (8 lb/hr)	
Work Place Temperature Range	0–40 °C (32–104 °F)	
Noise Level	64 dB (A) at maximum pump speed	B
Electrical/Controls		
Electrical Service	200–240 VAC 1Ø or 3Ø 230 VAC (with neutral) 1Ø or 400/230 VAC (with neutral) 3Ø	
Hose/Gun Heating Capacity	2, 4, or 6 hose/gun pairs	C
Control Temperature Range	38–232 °C (100–450 °F)	
Control Temperature Accuracy	+/- 0.5 °C (+/- 1 °F)	
Pump		
Air Pressure while Running	14:1 pump: 0.7–4.8 bar (70–620 kPa, 10–90 psi)	
Viscosity	800–30,000 mPa•s (up to 30,000 cps)	
Hydraulic Pressure (maximum while running)	14:1 pump: 8700 kPa (1260 psi)	
Air Consumption at 415 kPa (60 psi) and Maximum Pump Speed	14:1 pump: 46 l/min (1.6 standard ft ³ /min)	
Displacement	14:1 pump: 7.20 ml/stroke (0.44 in. ³ /stroke)	
Output Rate (maximum)	14:1 pump: 0.54 kg/min (1.2 lb/min)	D
Speed (maximum)	14:1 pump: 90 strokes/min	
<i>Continued...</i>		

Mesa 4 Melter *(contd)*

Tank		
Capacity	3.6 kg (8 lb)	
Volume	3.7 liters (230 in. ³)	
<p>NOTE A: Refer to Appendix C, <i>400/480 Volt Mesa Adhesive Melters</i>, for weights of 400/480 volt melters.</p> <p>B: The noise level is measured at a distance of 1 m from the surface of the unit and at a height of 1.6 m from the access platform.</p> <p>C: To determine the number of hose and gun pairs that your unit can heat, refer to <i>Melter Assembly Part Numbers</i> in Section 7, <i>Parts</i>.</p> <p>D: The output rate is based on a material density of 0.84 g/ml (0.03 lb/in.³) and a specific gravity of 0.84.</p>		

Mesa 6 Melter

Item	Specification	Notes
General		
Weight of Empty Unit	43.8 kg (96.5 lb)	A
Weight of Full Unit	49.8 kg (109.7 lb)	
Hose Ports	4	
Melt Rate	6.8 kg/hr (15 lb/hr)	
Work Place Temperature Range	0–40 °C (32–104 °F)	
Noise Level	64 dB (A) at maximum pump speed	B
Electrical/Controls		
Electrical Service	200–240 VAC 1Ø or 3Ø 230 VAC (with neutral) 1Ø or 400/230 VAC (with neutral) 3Ø	
Hose/Gun Heating Capacity	2 or 4 hose/gun pairs	C
Control Temperature Range	38–232 °C (100–450 °F)	
Control Temperature Accuracy	+/- 0.5 °C (+/- 1 °F)	
Pump		
Air Pressure while Running	14:1 pump: 0.7–4.8 bar (70–620 kPa, 10–90 psi)	
Viscosity	800–30,000 mPa•s (up to 30,000 cps)	
Hydraulic Pressure (maximum while running)	14:1 pump: 8700 kPa (1260 psi)	
Air Consumption at 415 kPa (60 psi) and Maximum Pump Speed	14:1 pump: 46 l/min (1.6 standard ft ³ /min)	
Displacement	14:1 pump: 7.20 ml/stroke (0.44 in. ³ /stroke)	
Output Rate (maximum)	14:1 pump: 0.54 kg/min (1.2 lb/min)	D
Speed (maximum)	14:1 pump: 90 strokes/min	
Tank		
Capacity	5.4 kg (12 lb)	
Volume	5.6 liters (340 in. ³)	
NOTE A: Refer to Appendix C, <i>400/480 Volt Mesa Adhesive Melters</i> , for weights of 400/480 volt melters. B: The noise level is measured at a distance of 1 m from the surface of the unit and at a height of 1.6 m from the access platform. C: To determine the number of hose and gun pairs that your unit can heat, refer to <i>Melter Assembly Part Numbers</i> in Section 7, <i>Parts</i> . D: The output rate is based on a material density of 0.84 g/ml (0.03 lb/in. ³) and a specific gravity of 0.84.		

Mesa 9 Melter

Item	Specification	Notes
General		
Weight of Empty Unit	45.4 kg (100.0 lb)	A
Weight of Full Unit	54.5 kg (120.0 lb)	
Hose Ports	4	
Melt Rate	9.5 kg/hr (21 lb/hr)	
Work Place Temperature Range	0–40 °C (32–104 °F)	
Noise Level	64 dB (A) at maximum pump speed	B
Electrical/Controls		
Electrical Service	200–240 VAC 1Ø or 3Ø 230 VAC (with neutral) 1Ø or 400/230 VAC (with neutral) 3Ø	
Hose/Gun Heating Capacity	4 hose/gun pairs	
Control Temperature Range	38–232 °C (100–450 °F)	
Control Temperature Accuracy	+/- 0.5 °C (+/- 1 °F)	
Pump		
Air Pressure while Running	14:1 pump: 0.7–4.8 bar (70–620 kPa, 10–90 psi)	
Viscosity	800–30,000 mPa•s (up to 30,000 cps)	
Hydraulic Pressure (maximum while running)	14:1 pump: 8700 kPa (1260 psi)	
Air Consumption at 415 kPa (60 psi) and Maximum Pump Speed	14:1 pump: 46 l/min (1.6 standard ft ³ /min)	
Displacement	14:1 pump: 7.20 ml/stroke (0.44 in. ³ /stroke)	
Output Rate (maximum)	14:1 pump: 0.54 kg/min (1.2 lb/min)	C
Speed (maximum)	14:1 pump: 90 strokes/min	
Tank		
Capacity	8.6 kg (19 lb)	
Volume	8.9 liters (540 in. ³)	
<p>NOTE A: Refer to Appendix C, <i>400/480 Volt Mesa Adhesive Melters</i>, for weights of 400/480 volt melters.</p> <p>B: The noise level is measured at a distance of 1 m from the surface of the unit and at a height of 1.6 m from the access platform.</p> <p>C: The output rate is based on a material density of 0.84 g/ml (0.03 lb/in.³) and a specific gravity of 0.84.</p>		

Mesa 14 Melter

Item	Specification	Notes
General		
Weight of Empty Unit	60 kg (132 lb)	
Weight of Full Unit	73.6 kg (162 lb)	
Hose Ports	6	
Melt Rate	13.6 kg/hr (30 lb/hr)	
Work Place Temperature Range	0–40 °C (32–104 °F)	
Noise Level	64 dB (A) at maximum pump speed	A
Electrical/Controls		
Electrical Service	200–240 VAC 1Ø (4 H/G only) or 3Ø 230 VAC (with neutral) 1Ø (4H/G only) or 400/230 VAC (with neutral) 3Ø	
Hose/Gun Heating Capacity	4 or 6 hose/gun pairs	B
Control Temperature Range	38–232 °C (100–450 °F)	
Control Temperature Accuracy	+/- 0.5 °C (+/- 1 °F)	
Pump		
Air Pressure while Running	10:1 or 14:1 pump: 0.7–4.8 bar (70–620 kPa, 10–90 psi) 21:1 pump: 0.7–6.2 bar (70–483 kPa, 10–70 psi)	
Viscosity	800-30,000 mPa•s (up to 30,000 cps)	
Hydraulic Pressure (maximum while running)	10:1 pump: 6,200 kPa (900 psi) 14:1 pump: 8,700 kPa (1,260 psi) 21:1 pump: 10,400 kPa (1,500 psi)	
Air Consumption at 415 kPa (60 psi) and Maximum Pump Speed	10:1 pump: 41 l/min (1.5 standard ft ³ /min) 14:1 pump: 46 l/min (1.6 standard ft ³ /min) 21:1 pump: 115 l/min (4.1 standard ft ³ /min)	
Displacement	10:1 pump: 35 ml/stroke (2.14 in. ³ /stroke) 14:1 pump: 7.20 ml/stroke (0.44 in. ³ /stroke) 21:1 pump: 16.00 ml/stroke (1.00 in. ³ /stroke)	
Output Rate (maximum)	14:1 pump: 0.54 kg/min (1.20 lb/min) 10:1 pump: 0.67 kg/min (1.50 lb/min) 21:1 pump: 910 g/min (2.00 lb/min)	C
Speed (maximum)	10:1 pump: 13 strokes/min 14:1 pump: 90 strokes/min 21:1 pump: 66 strokes/min	
Tank		
Capacity	13.6 kg (30 lb)	
Volume	13.7 liters (836 in. ³)	
NOTE A: The noise level is measured at a distance of 1 m from the surface of the unit and at a height of 1.6 m from the access platform. B: To determine the number of hose and gun pairs that your unit can heat, refer to <i>Melter Assembly Part Numbers</i> in Section 7, <i>Parts</i> . C: The output rate is based on a material density of 0.84 g/ml (0.03 lb/in. ³) and a specific gravity of 0.84.		

Electrical Specifications

NOTE: Refer to *Configuring the Electrical Service* in Section 3, *Installation*, for maximum amperage specifications.

Item	Data	Note
Hose/gun heating capacity	2 or 4 hose/gun pair	
Control temperature range (240 and 120 VAC)	40 to 230 °C (100 to 450 °F)	
Control temperature accuracy	± 0.5 °C (± 1 °F)	
IP rating	IP 32	

Heater Specifications

NOTE: Refer to the hose and gun manuals for hose/gun heater specifications.

Location	Voltage	Wattage (see Note A)	Cold Resistance (see Note B)
Tank, M4	230 V	1700	28–33 ohms
Tank, M6	230 V	2000	23–28 ohms
Tank, M9	230 V	2800	17–20 ohms
Tank, M14	230 V	3800	12–15 ohms

NOTE A: Nominal wattage at 177–204 °C (350–400 °F).
 B: Measured at room temperature for a previously heated element.

Melter Dimensions

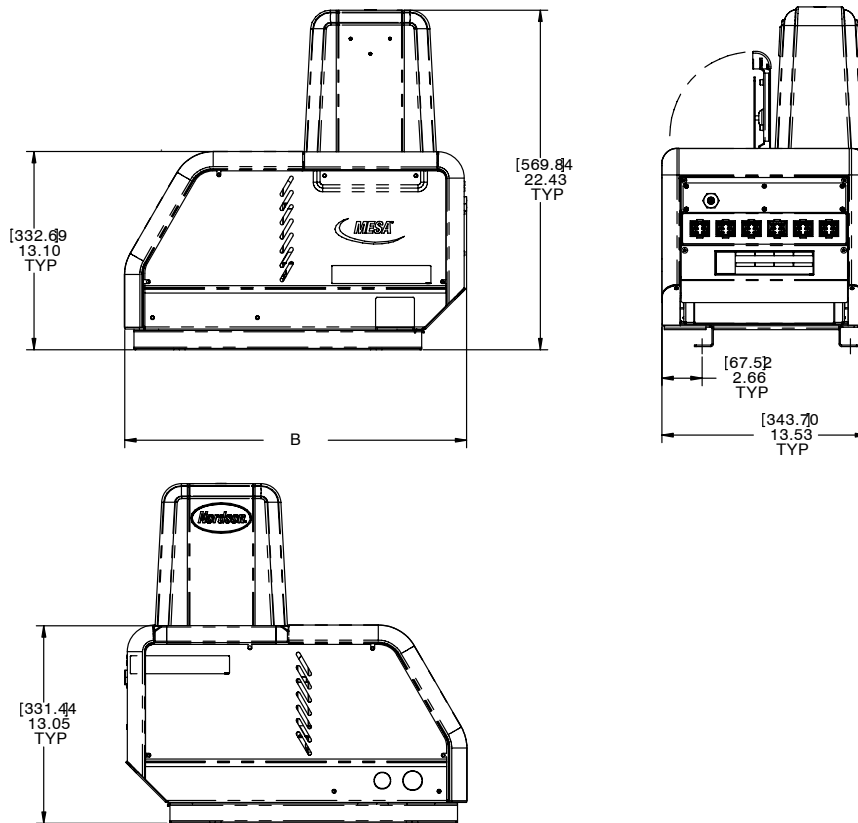

Figure 8-1 Melter dimensions (refer to Table 8-1)

Table 8-1 Melter Dimension B

Item	Required Clearance			
	M4	M6	M9	M14
B	573.82 mm (22.59 in.)	625 mm (24.61 in.)	690 mm (27.17 in.)	835 mm (32.88 in.)

Wiring Diagram

NOTE: Refer to Appendix C, 400/480 Volt Mesa Adhesive Melters, for 400/480 volt wiring diagrams.

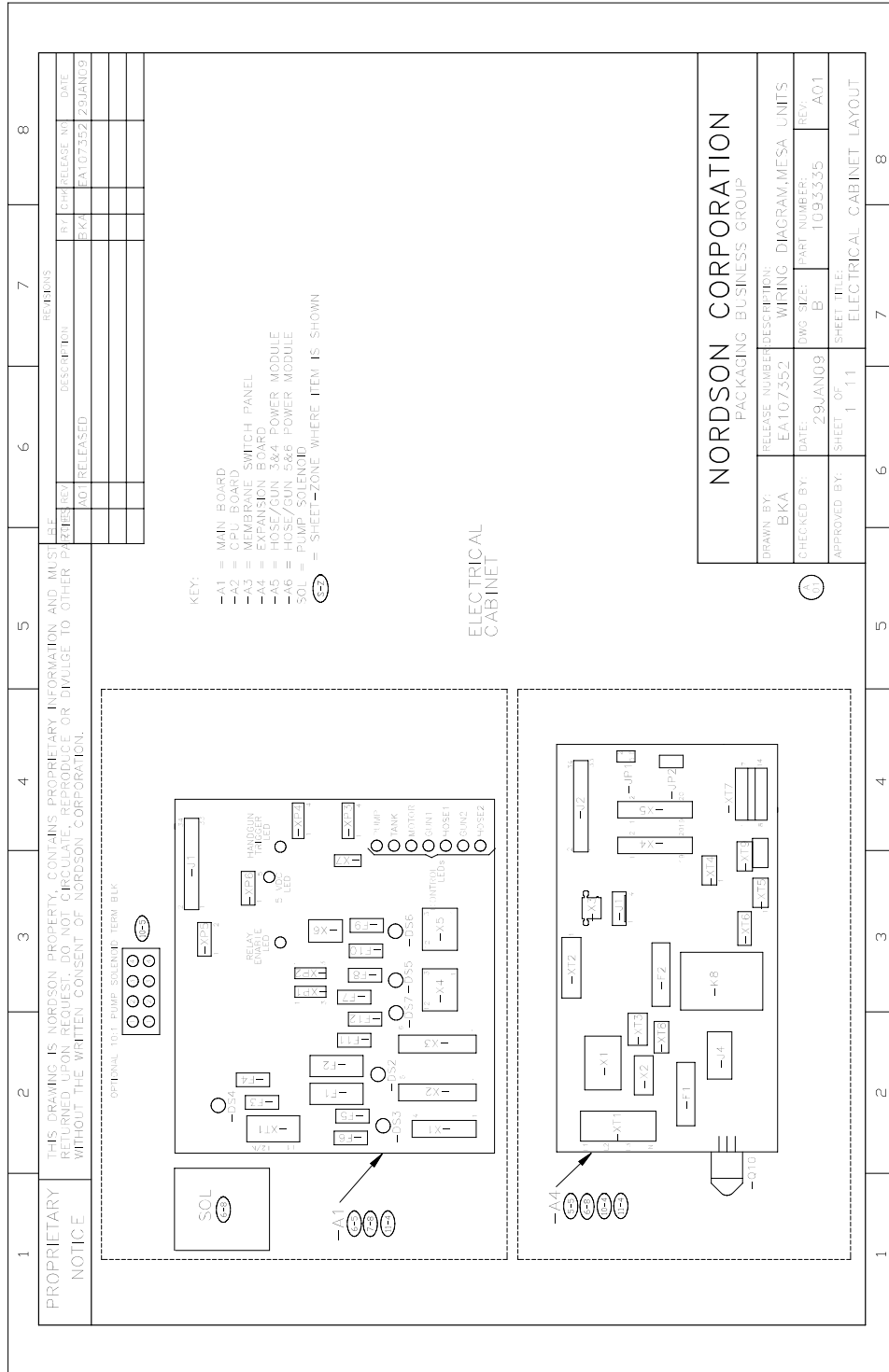

Figure 8-2 Wiring diagram (1 of 11)

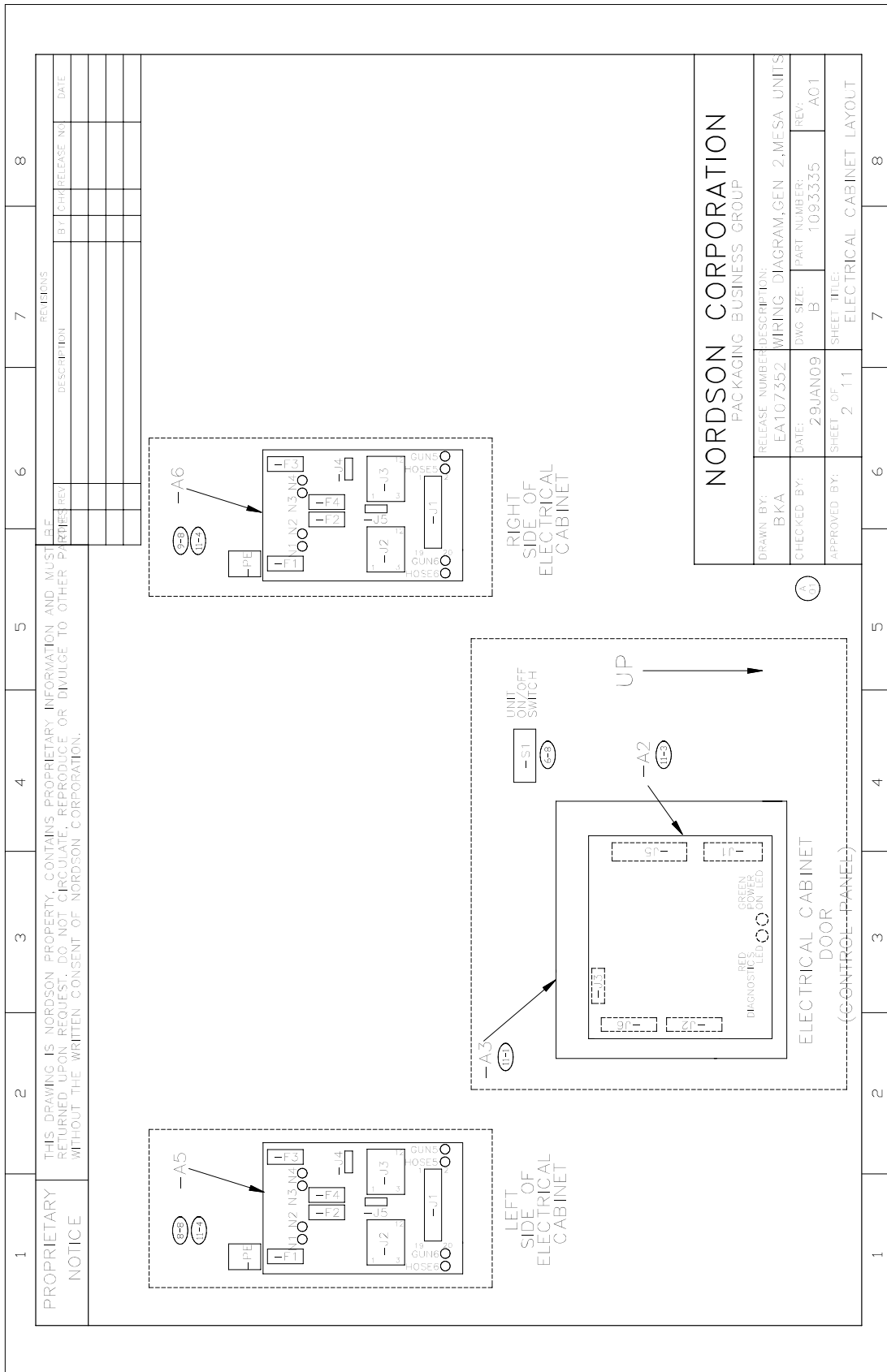

Figure 8-3 Wiring diagram (2 of 11)

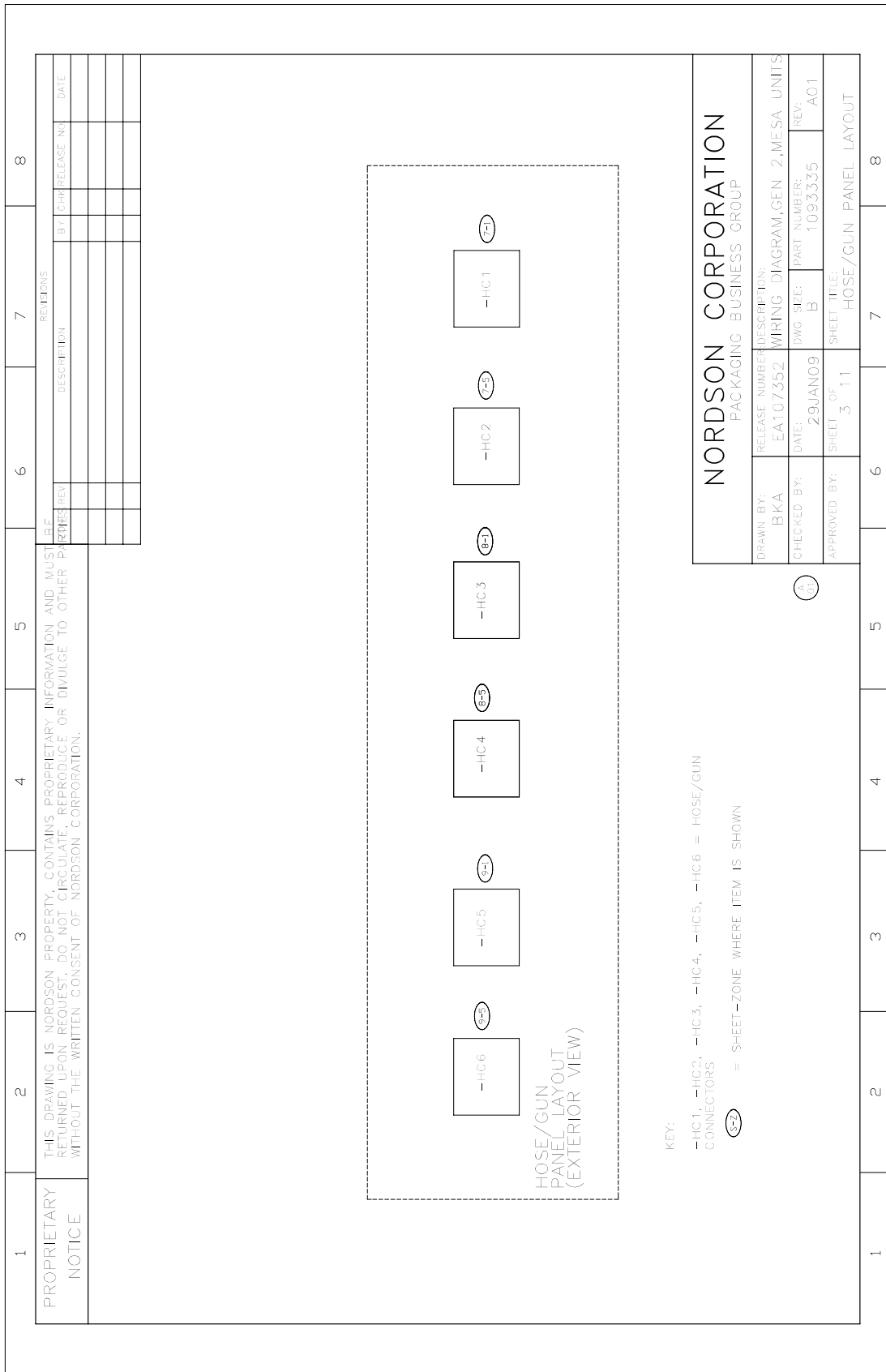

Figure 8-4 Wiring diagram (3 of 11)

1	2	3	4	5	6	7	8																																																				
<p style="text-align: center;">THIS DRAWING IS NORDSON PROPERTY; CONTAINS PROPRIETARY INFORMATION AND MUST BE RETURNED UPON REQUEST. DO NOT CIRCULATE, REPRODUCE OR DIVULGE TO OTHER PERSONS WITHOUT THE WRITTEN CONSENT OF NORDSON CORPORATION.</p>				<p style="text-align: center;">REVOLUTIONS</p> <table border="1" style="width: 100%; border-collapse: collapse;"> <thead> <tr> <th style="width: 10%;">REV#</th> <th style="width: 50%;">DESCRIPTION</th> <th style="width: 10%;">BY</th> <th style="width: 10%;">DATE</th> </tr> </thead> <tbody> <tr><td> </td><td> </td><td> </td><td> </td></tr> <tr><td> </td><td> </td><td> </td><td> </td></tr> <tr><td> </td><td> </td><td> </td><td> </td></tr> <tr><td> </td><td> </td><td> </td><td> </td></tr> <tr><td> </td><td> </td><td> </td><td> </td></tr> </tbody> </table>				REV#	DESCRIPTION	BY	DATE																					<p style="text-align: center;">DRAWING INFORMATION</p> <table border="1" style="width: 100%; border-collapse: collapse;"> <tr> <td style="width: 25%;">DRAWN BY:</td> <td style="width: 25%;">RELEASE NUMBER:</td> <td style="width: 25%;">DESCRIPTION:</td> <td style="width: 25%;"> </td> </tr> <tr> <td> </td> <td>EA107352</td> <td>WIRING DIAGRAM, GEN 2, MESA UNITS</td> <td> </td> </tr> <tr> <td>CHECKED BY:</td> <td>DATE:</td> <td>DWG SIZE:</td> <td>PART NUMBER:</td> </tr> <tr> <td> </td> <td>29JAN09</td> <td>B</td> <td>1093335</td> </tr> <tr> <td>APPROVED BY:</td> <td>SHEET OF:</td> <td>SHEET TITLE:</td> <td>REV#:</td> </tr> <tr> <td> </td> <td>4 11</td> <td>LIST OF DRAWINGS</td> <td>A01</td> </tr> </table>				DRAWN BY:	RELEASE NUMBER:	DESCRIPTION:			EA107352	WIRING DIAGRAM, GEN 2, MESA UNITS		CHECKED BY:	DATE:	DWG SIZE:	PART NUMBER:		29JAN09	B	1093335	APPROVED BY:	SHEET OF:	SHEET TITLE:	REV#:		4 11	LIST OF DRAWINGS	A01
REV#	DESCRIPTION	BY	DATE																																																								
DRAWN BY:	RELEASE NUMBER:	DESCRIPTION:																																																									
	EA107352	WIRING DIAGRAM, GEN 2, MESA UNITS																																																									
CHECKED BY:	DATE:	DWG SIZE:	PART NUMBER:																																																								
	29JAN09	B	1093335																																																								
APPROVED BY:	SHEET OF:	SHEET TITLE:	REV#:																																																								
	4 11	LIST OF DRAWINGS	A01																																																								
<p style="text-align: center;">PROPRIETARY NOTICE</p>				<p style="text-align: center;">NORDSON CORPORATION PAC KAGING BUSINESS GROUP</p>																																																							
<p>LIST OF DRAWINGS:</p> <p>PAGE 1: ELECTRICAL CABINET LAYOUT</p> <p>PAGE 2: ELECTRICAL CABINET LAYOUT</p> <p>PAGE 3: HOSE/GUN PANEL LAYOUT</p> <p>PAGE 4: LIST OF DRAWINGS</p> <p>PAGE 5: INPUT POWER</p> <p>PAGE 6: INTERNAL ZONES</p> <p>PAGE 7: HOSES/GUNS 1&2</p> <p>PAGE 8: HOSES/GUNS 3&4</p> <p>PAGE 9: HOSES/GUNS 5&6</p> <p>PAGE 10: INPUTS/OUTPUTS</p> <p>PAGE 11: RIBBON CABLES, MISC. GROUNDS</p>																																																											
1	2	3	4	5	6	7	8																																																				

Figure 8-5 Wiring diagram (4 of 11)

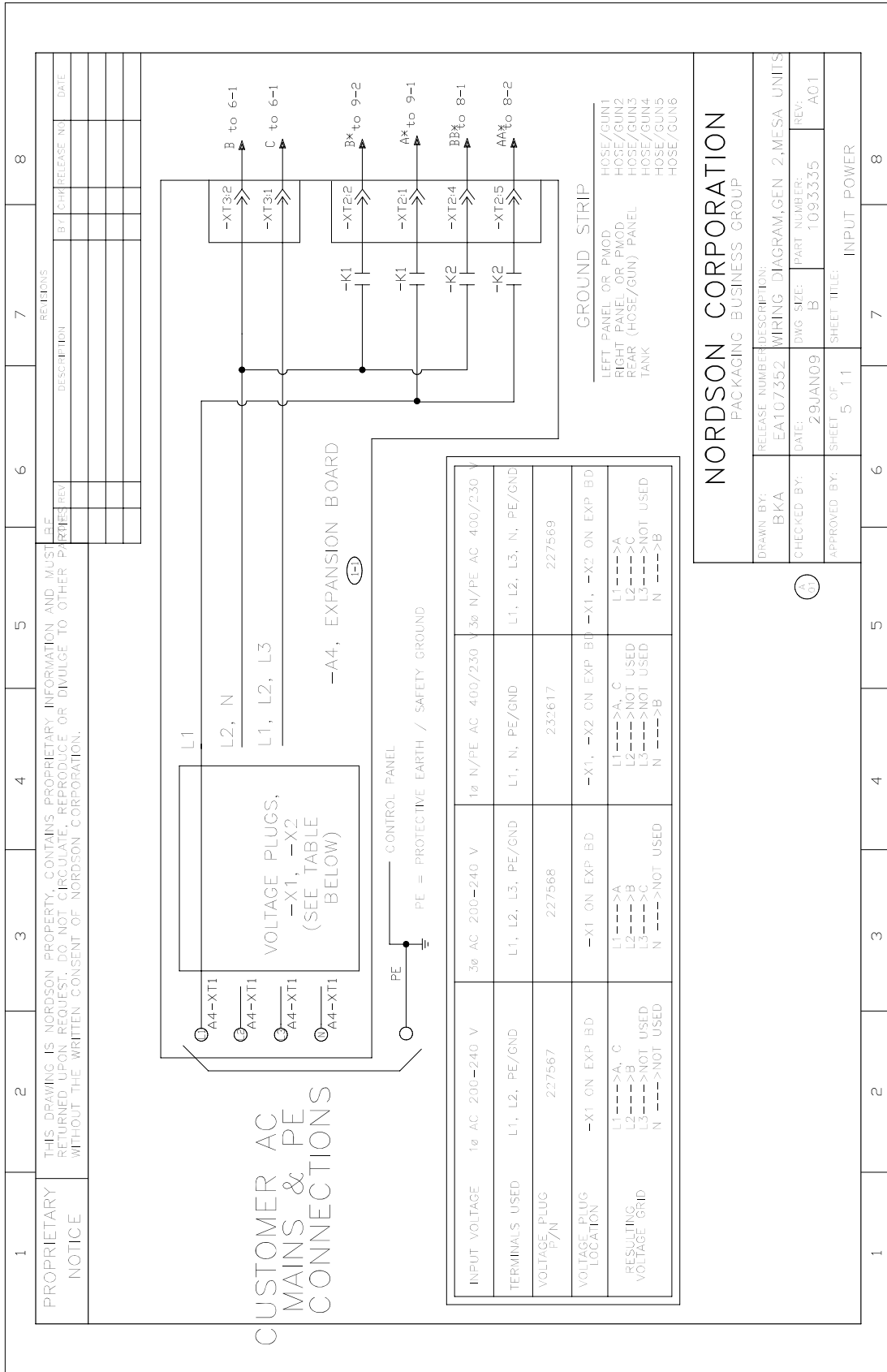

Figure 8-6 Wiring diagram (5 of 11)

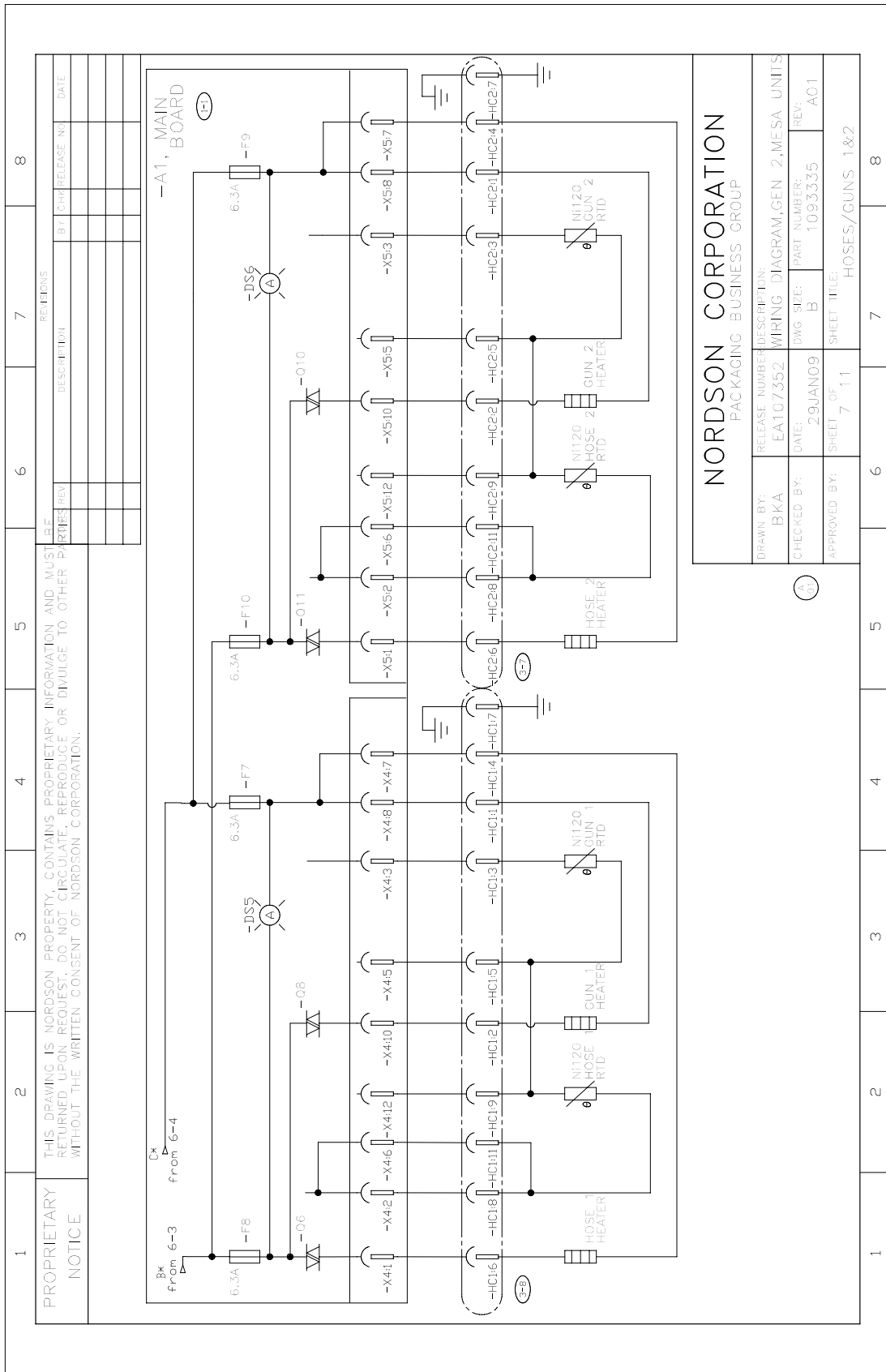

Figure 8-8 Wiring diagram (7 of 11)

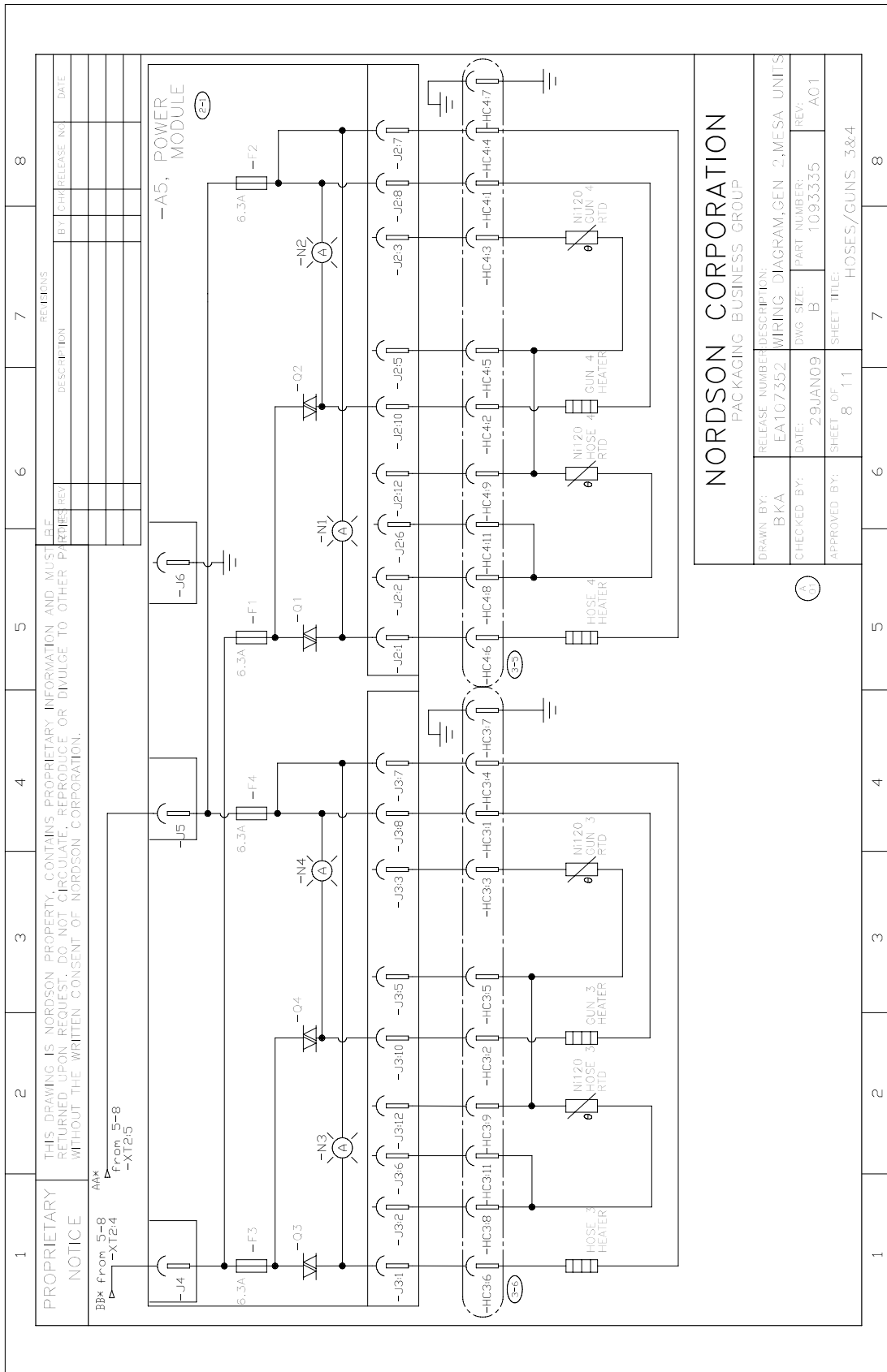

Figure 8-9 Wiring diagram (8 of 11)

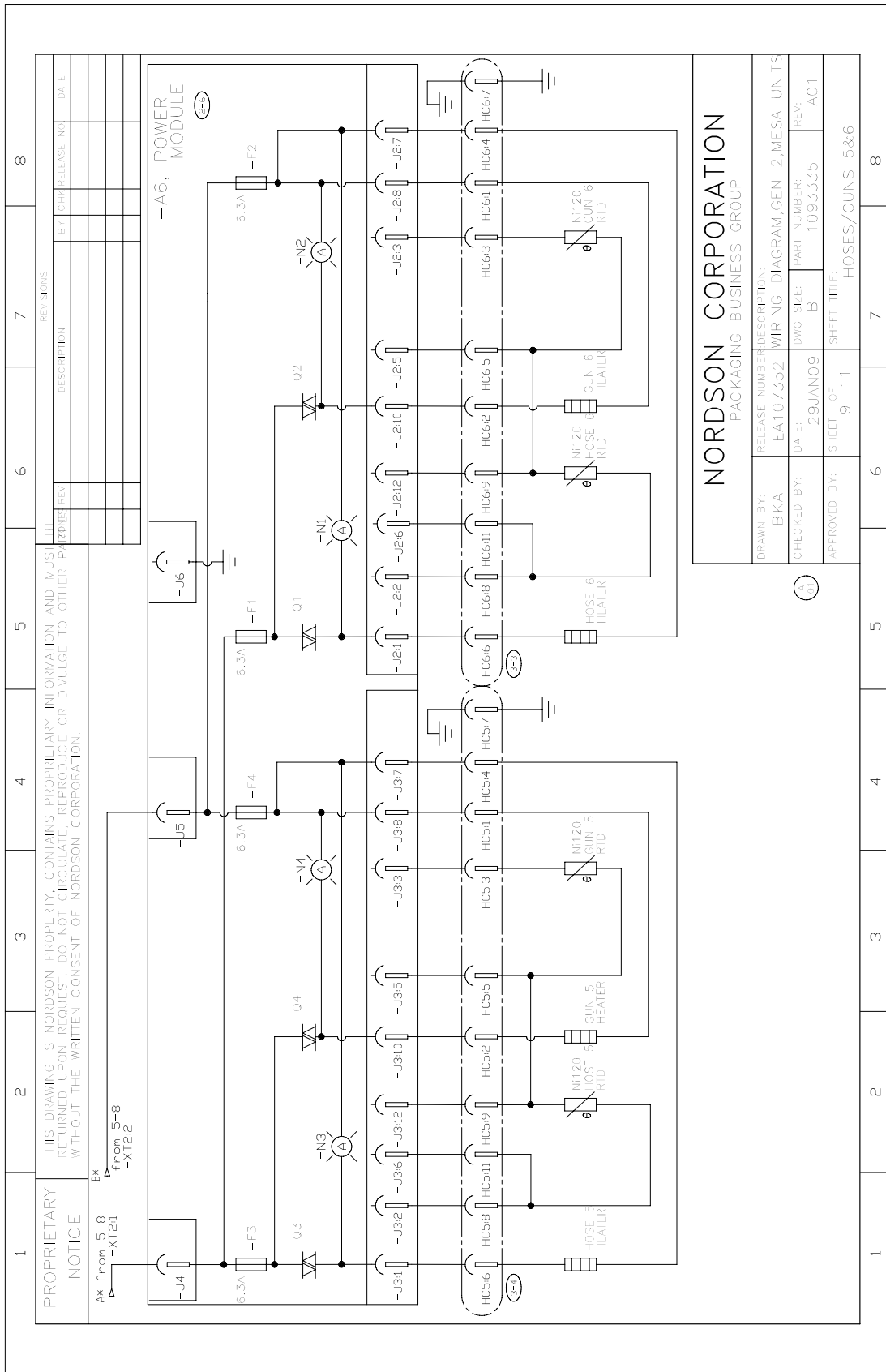

Figure 8-10 Wiring diagram (9 of 11)

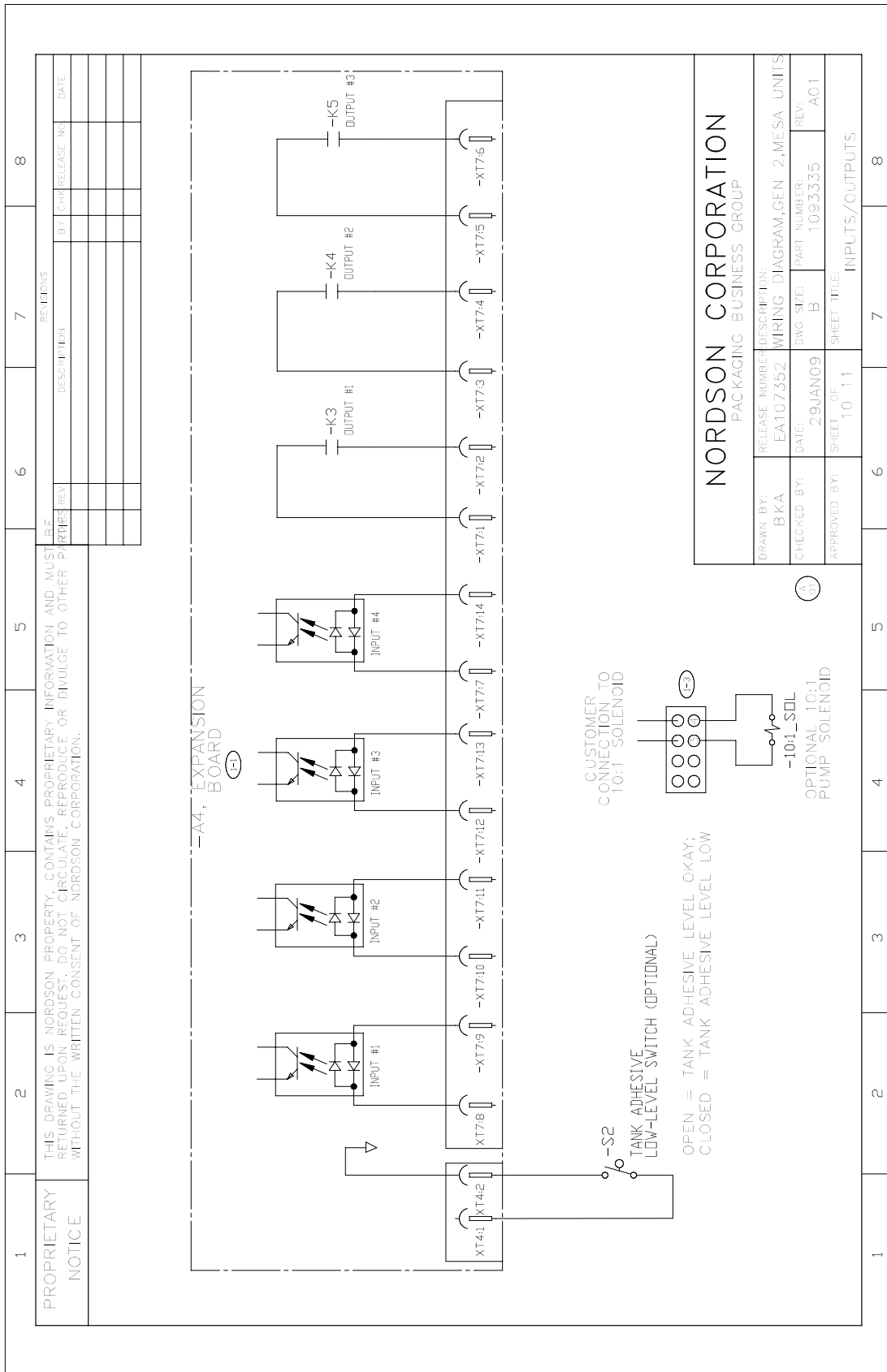

Figure 8-11 Wiring diagram (10 of 11)

Appendix A

Calculating Melter Power Requirements

When you connect hoses and guns to your hot melt melter, you must make sure the electrical power requirements of those hoses and guns do not exceed the maximum wattages allowed for your system. Exceeding the allowed maximum wattage can damage your equipment or keep your system from functioning properly.

For every Mesa melter system, there are three maximum wattages you must not exceed:

- **The single-component maximum wattage:** the wattage of any single hose or gun connected to your melter must not exceed this wattage.
- **The hose/gun pair maximum wattage:** the wattage of any hose and gun (hose/gun pair) connected to your melter must not exceed this wattage.
- **The total hose/gun maximum wattage:** the wattage of all hoses and guns connected to your melter must not exceed this wattage.

To make sure your system does not exceed any of these maximum wattages, someone (either you or your Nordson representative) must calculate the hose/gun capacity for your system. If your Nordson representative has already made this calculation for the actual hoses and guns you plan to use, you do not need to repeat the calculation now. However, you must make this calculation

- if the hose/gun capacity has not been calculated for your system
- if you have reconfigured your system since the calculations were made
- whenever you add new hoses or guns to an existing system
- whenever you replace an existing hose with a longer one or an existing gun with a larger one

Calculating Hose/Gun Capacity

Use this procedure to calculate the hose/gun capacity for your system. Throughout this procedure there are places for you to record important information. These records provide you with a quick reference and make recalculations easier.

1. Refer to *Melter Assembly Part Numbers* in Section 7, *Parts*, to determine the model (Mesa 4, 6, or 9) of your melter. Record the model below.

Model:

2. Refer to *Melter Assembly Part Numbers* in Section 7, *Parts*, to determine the hose/gun capacity (2 or 4) of your melter. Record the hose/gun capacity below.

Hose/gun capacity (2 or 4):

3. Determine the the type of electrical service supplied to your melter. If necessary, refer to Section 3, *Installation*, and compare the electrical installation instructions to the electrical connections inside your melter. The electrical service will be one of the following:
 - 400/230 VAC 3-phase (with neutral)
 - 230 VAC 1-phase (with neutral)
 - 200–240 VAC 3-phase (without neutral)
 - 200–240 VAC 1-phase (without neutral)

Record the electrical service below.

Electrical service:

4. The single-component maximum wattage for all Mesa melters is 1,000 W. This information is recorded for you in Table A-2.

Table A-2 Single-Component Maximum Wattage

Record of Single-Component Maximum Wattage:	1,000 W
--	---------

5. The hose/gun pair maximum wattage for all Mesa melters is 1,200 W. This information is recorded for you in Table A-3.

Table A-3 Hose/Gun Pair Maximum Wattage

Record of Hose/Gun Pair Maximum Wattage:	1,200 W
---	---------

- Using the electrical service information you recorded in step 3., refer to Table A-4 to determine which table in the *Power Data Tables* portion of this procedure you will use to determine the maximum wattage of all hoses and guns you can use in your system. Record the correct table for your system in the last column of the table.

Table A-4 Correct Table in *Power Data Tables* for Your System

Electrical Service	Table in <i>Power Data Tables</i>	Record of Correct Table in <i>Power Data Tables</i> for Your System
230 VAC 1-phase (with neutral)	Table A-8	
400/230 VAC 3-phase (with neutral)		
200–240 VAC 1-phase (without neutral)	Table A-9	
200–240 VAC 3-phase (without neutral)		

- Using the information you recorded in steps 1., 2., and Table A-4, refer to *Power Data Tables* and obtain the value listed in the *Total Hose/Gun Maximum Wattage* column for your system. Record the total hose/gun maximum wattage for your system in the space below:

NOTE: You do not need to use the data in the remaining columns of the table. This data is for reference only.

Table A-5 Total Hose/Gun Maximum Wattage for Your System

Record of Total Hose/Gun Maximum Wattage for Your System

- In the table below, record the total maximum wattages you recorded in Tables A-2, A-3, and A-5.

Table A-6 Maximum Wattages for Your System

Type of Maximum Wattage	Refer to...	Record of Maximum Wattages for Your System
Single-component maximum wattage	Table A-2	
Hose/gun pair maximum wattage	Table A-3	
Total hose/gun maximum wattage	Table A-5	

Calculating Hose/Gun Capacity *(contd)*

9. Refer to Table A-10 under *Power Data Tables* and determine the actual required wattage for each hose and gun in your system. Use the column in Table A-10 that matches the type of electrical service connected to your melter (which you recorded in step 6). Using the data from Table A-10, complete the following table.

NOTE: Table A-10 lists the power requirements for only the most common Nordson hoses and guns. If you do not find the hose or gun you are using in the table, contact your Nordson representative for wattage information.

Table A-7 Actual Hose/Gun Wattages for Your System

Hoses and Guns	Actual Wattage of Each Single Hose or Gun from Table A-10	Actual Combined Wattage of Each Hose/Gun Pair
Hose 1		
Gun 1		
Hose 2		
Gun 2		
Hose 3		
Gun 3		
Hose 4		
Gun 4		
Hose 5		
Gun 5		
Hose 6		
Gun 6		
Actual Wattage Total for All Hoses and Guns in Your System (sum of above entries)		

10. Compare the maximum wattages you recorded in Table A-6 to the actual wattages you recorded in Table A-7 for each of the following:
 - Wattage of each individual hose and gun
 - Combined wattage of each hose/gun pair
 - Total wattage of all hoses and guns

If your actual wattages exceed your maximum wattages in any category, you will need to reconfigure your system or order different hoses or guns. Contact your Nordson representative for assistance.

Power Data Tables

Use these tables as directed in *Calculating Hose/Gun Capacity*.

Table A-8 230 VAC 1-Phase (With Neutral) or 400/230 VAC 3-Phase (With Neutral)

Model	Hose/Gun Electrical Capacity	Type of Power	Total Hose/Gun Maximum (W)	Internal Component Power (W)	System Power Maximum (W)	Current	
						1 \emptyset (A) 230 VAC	3 \emptyset (A) 230 VAC
Mesa 4	2	1, 3 \emptyset	2000	1723	3723	16	16
	4	1, 3 \emptyset	4000	1723	5723	25	16
	6	1, 3 \emptyset	6000	1723	7723	34	17
Mesa 6	2	1, 3 \emptyset	2000	2023	4023	17	17
	4	1, 3 \emptyset	4000	2023	6023	26	17
Mesa 9	4	1, 3 \emptyset	4000	2823	6823	30	21
Mesa 14	4	1, 3 \emptyset	4000	3823	7823	34	25
	6	3 \emptyset	6000	3823	9823	--	25

Table A-9 200–240 VAC 1-Phase (Without Neutral) or 200–240 VAC 3-Phase (Without Neutral)

Model	Hose/Gun Electrical Capacity	Type of Power	Total Hose/Gun Maximum (W)	Internal Component Power (W)	System Power Maximum (W)	Current	
						1 \emptyset (A) 240 VAC	3 \emptyset (A) 240 VAC
Mesa 4	2	1, 3 \emptyset	2086	1876	3962	17	17
		1, 3 \emptyset	4172	1876	6048	25	22
	4	1, 3 \emptyset	2086	1876	3962	17	17
Mesa 6	4	1, 3 \emptyset	4172	1876	6048	25	22
		1, 3 \emptyset	6258	1876	8134	34	29
	2	1, 3 \emptyset	2086	2203	4289	18	18
Mesa 9	4	1, 3 \emptyset	4172	2203	6375	27	23
		1, 3 \emptyset	4172	3074	7246	30	27
Mesa 14	4	1, 3 \emptyset	4172	4163	8335	35	31
		3 \emptyset	6258	4163	10421	--	38

Power Data Tables *(contd)*

Table A-10 Actual Power Requirements (Wattages) for Nordson Hoses and Guns

Hose or Gun Type	Type of Electrical Service (See Note A)	
	200–240 VAC 1-Phase or 200–240 VAC 3-Phase (without neutral)	230 VAC 1-Phase or 400/230 VAC 3-Phase (with neutral)
Auto hose (0.6 m, 2 ft)	49	45
Auto hose (1.2 m, 4 ft)	109	100
Auto hose (1.8 m, 6 ft)	169	155
Auto hose (2.4 m, 8 ft)	223	205
Auto hose (3 m, 10 ft)	289	265
Auto hose (3.6 m, 12 ft)	343	315
Auto hose (4.8 m, 16 ft)	457	420
Auto hose (7.2 m, 24 ft)	691	635
Manual hose (2.4 m, 8 ft)	223	205
Manual hose (4.8 m, 16 ft)	457	420
H-201 gun (T or T-L)	152	140
H-202 gun (T or T-L)	229	210
H-204 gun (T or T-L)	283	260
H-208 gun (T or T-L)	440	405
H-202 gun (T-E or T-E-L)	365	335
H-204 gun (T-E or T-E-L)	381	350
H-202 gun (T-LP or T-LP-L)	201	185
H-204 gun (T-LP or T-LP-L)	310	285
H-208 gun (T-LP or T-LP-L)	424	390
H-20 gun (T or T-L0)	147	135
H-20 gun with micro (T)	174	160

NOTE A: Actual line voltage in a plant may vary from nominal voltage by as much as ±15%. To calculate the actual power requirements at other line voltages, use the following formula:

$$PL = PN \times \left[\frac{EL}{EN} \right]^2$$

In this formula, PL is the wattage at line voltage, PN is the wattage at nominal voltage, EL is the line voltage, and EN is the nominal voltage.

Appendix B

Operating Parameters

Operating parameters are organized in this appendix according to the logical groups listed in Table B-1. For information about selecting and editing operating parameters, refer to Section 3, *Installation, Setting Up the Melter*.

NOTE: Parameter numbers that are reserved or that are not used do not appear in this appendix.

Table B-1 Parameter Groups

Group	Parameter Numbers	Group Description
Standard	0 to 4, 10 to 11, and 14	Frequently used parameters
Temperature Control	20 to 25	Control heater function
Seven-day Clock	50 to 77	Configure the clock feature

NOTE: Refer to Table 3-7 for the exact parameters available on Mesa melters.

Standard

0 Enter Password

Description:	A user-defined password that prevents unauthorized changes to setpoint temperatures and operating parameters.
Value:	0 to 9999
Resolution:	1
Default Value:	4000
Format:	—
Use:	This parameter only appears if a password is created using parameter 11 and then enabled using parameter 10. NOTE: The melter remains in the password-protected mode for two minutes after the last key press. After exiting the setup mode, attempting to re-enter the setup mode, even before two minutes has elapsed, will require you to re-enter the password.

1 Total Hours with Heaters On (Noneditable)

Description:	A noneditable value that indicates the total number of hours that the heaters have been on.
Value:	999,999 (using abbreviated convention described below)
Resolution:	1 hour
Default Value:	0
Format:	—
Use:	The right display indicates up to 9999 hours of heater operation. When the accumulated heater hours reaches 10,000, the display alternates every two seconds between the three left most digits (thousands) and the three right digits (hundreds). For example, 10,001 hours would be displayed as "10," for two seconds and then "001" for two seconds. The comma is present if parameter 20, <i>Temperature Units</i> , is set to degrees Fahrenheit. A period is present if parameter 20 is set to degrees Celsius.

2 Fault Log (Noneditable)

Description:	Stores a record of the last ten faults.
Value:	—
Resolution:	—
Default Value:	_-F0 (unused log entry)
Format:	F1, F2, F3, and F4
Use:	Use the right-display scroll keys to review the log entries for the last ten faults. Empty log entries are indicated by "_-F0." Refer to <i>Monitor the Melter</i> in Section 4, <i>Operation</i> .

3 Change History Log**(Noneditable)**

Description:	Records the last ten changes made to either the setpoint temperatures or the operating parameters.
Value:	—
Resolution:	—
Default Value:	P_ (unused log entry)
Format:	Refer to Section 3, <i>Installation, Review Parameter and Setpoint Temperature Changes</i> .
Use:	Use the right-display key to review the log entries for the last ten changes that were made to the operating parameters or the setpoint temperatures. Empty log entries are indicated by "P_."

4 Ready Delay Time

Description:	The amount of time that will elapse after all of the components have reached their setpoint temperature before the ready LED will turn on. The ready delay time only functions when the temperature of the tank, at the time the melter is turned on, is more than 27 °C (50 °F) from its setpoint temperature. The ready delay time begins when all components are within 3 °C (5 °F) of their respective setpoint temperature.
Value:	0 to 60 minutes
Resolution:	1 minute
Default Value:	0 minutes
Format:	Left display "rd." Right display, minutes or seconds remaining.
Use:	The ready delay allows the contents of the tank an additional amount of time to heat before pump turns on. NOTE: The time remaining on the ready delay is indicated in minutes in the right display at the end of every automatic scan cycle. When the delay time reaches 1 minute, the time remaining appears in seconds.

10 Enable or Disable the Melter Password

Description:	Activates or deactivates the melter password. When password protection is activated, component setpoint temperatures or melter operating parameters cannot be changed until a valid password is entered using parameter 0.
Value:	0 (disabled) 1 (enabled) 2 (Operator)
Resolution:	—
Default Value:	0
Format:	—
Use:	A password must first be created using parameter 11 before it can be enabled or disabled using parameter 10. Option 2 only allows changes to be made to setpoint and standby temperatures.

Standard *(contd)*

11 Create Password

Description:	A user-defined password that prevents unauthorized changes to operating parameters or setpoint temperatures.
Value:	0 to 9999
Resolution:	1
Default Value:	5000
Format:	—
Use:	Refer to Section 4, <i>Operation, Entering the Melter Password</i> .
	NOTE: When the password is created and enabled, parameter 10 will not appear again in the right display until the password is entered.

14 External Communications Lock-out

Description:	Used as a safety feature when performing maintenance on the melter. Prevents external control of the melter through standard or optional inputs/outputs or network communications (optional)
Value:	0 (disabled) or 1 (enabled)
Resolution:	—
Default Value:	0 (disabled)
Format:	—
Use:	Set parameter to 1 (enabled) before performing any maintenance on the melter. When enabled, all external control of the melter stops until the parameter is once again set to 0 (disabled).

Temperature Control

20 Temperature Units

Description:	Sets the units for temperature display.
Value:	C (degrees Celsius) or F (degrees Fahrenheit)
Resolution:	1 degree
Default Value:	C
Format:	—
Use:	—

21 Over Temperature Delta

Description:	The number of degrees that the temperature of any component can increase over its assigned setpoint temperature before an over temperature fault (F3) will occur.
Value:	Three temperature settings are available: 15, 25, and 35 °C (25, 50, and 75 °F)
Resolution:	—
Default Value:	15 °C (25 °F)
Format:	—
Use:	—

22 Under Temperature Delta

Description:	The number of degrees that the temperature of any component can decrease from its setpoint temperature before an under temperature fault (F2) occurs.
Value:	Three temperature settings are available: 15, 25, and 35 °C (25, 50, and 75 °F)
Resolution:	—
Default Value:	25 °C (50 °F)
Format:	—
Use:	—

Temperature Control *(contd)*

23 Standby Delta

Description:	The number of degrees by which all heated components will be decreased when the melter is placed into the standby mode.
Value:	Three temperature settings are available: 30, 50, and 80 °C (50, 100, and 150 °F)
Resolution:	—
Default Value:	50 °C (100 °F)
Format:	—
Use:	A standby delta should be selected that results in a balance between melter energy savings during periods of inactivity, the amount of time and energy required to bring the melter back up to setpoint temperature, and a temperature at which the hot melt can be held in the tank for extended periods of time without charring. Refer to Section 4, <i>Operation, Using Melter Function Keys</i> .
	NOTE: The standby delta does not affect the under temperature delta (parameter 22).

24 Automatic Standby Timeout

Description:	The amount of time that must elapse after the last signal (gun driver) is sent to input 1 before the melter will enter the standby mode. The automatic standby timeout feature saves energy by allowing the melter to automatically go into the standby mode if the melter detects that the guns are no longer firing.
Value:	Three time settings are available: 0, 120, or 150 minutes
Resolution:	—
Default Value:	0 (disabled)
Format:	—
Use:	1. Change parameter 23 if required. 2. Set the control option for parameter 30 (input 1) to option 10 (automatic standby)
	NOTE: Only enable parameter 24 when a 24 VDC signal voltage is connected to input 1. If there is no voltage on the input contacts when the melter is ready, the melter will enter the standby mode after the automatic standby time.

25 Automatic Heaters Off Time

Description:	The amount of time that must elapse after the automatic standby time elapses (parameter 24) before the heaters turn off.
Value:	Three time settings are available: 1, 60, or 120 minutes
Resolution:	—
Default Value:	0 (disabled)
Format:	—
Use:	Set parameter 24 (automatic standby timeout) to the desired value before setting parameter 25.

This page intentionally left blank.

Seven-day Clock

Before setting up the clock, refer to *Using Melter Function Keys* in Section 4, *Operation*, to familiarize yourself with the function and use of the clock feature.

If you are unfamiliar with the procedure for accessing and editing operating parameters, refer to Section 3, *Installation, Setting Up the Melter*.

To set the clock

Refer to the examples on the next page.

1. Use parameter 50 to select the current day of the week.
2. Use parameter 51 to set the current time of day.
3. Create the clock schedule by:
 - a. Setting parameters 55 and 56 to the time of the day that the heaters should turn on and off.
 - b. Setting parameters 57 and 58 to the time of the day that the melter should enter and exit the standby mode.
4. (Optional – Applies only if optional I/O card is installed)
Using parameters 60 through 68, create schedules 2 and 3 by repeating step 3.
5. Use parameters 71 through 77 to assign the days of the week that the schedule should be used.

NOTE: When the optional I/O card is installed, up to three schedules may be assigned each day (to support three work shifts). Each of the eight control options (0 to 7) that is available in parameters 71 through 77 assigns a different combination of the three schedules. Option 0 is used hold the melter in the state dictated by the last clock transition until the next clock transition occurs.

6. Press the **Clock** key.



In order for the clock to operate continuously throughout the week, a valid schedule must be assigned to every day of the week (parameters 71 through 77).

To prevent unintentional activation of the clock the default setting for parameters 71 through 77 is schedule 0, which has no time values assigned to it. With the default set to schedule 0, unintentionally pressing the clock key will have no affect on the melter.

Example 1

To turn the heaters on at 0600 and turn them off at 0015 every day of the week:

Par 55 = 0600
Par 56 = 0015
Par 60 = - - - -
Par 61 = - - - -
Par 71 through 77 = 1

Example 2

To turn the heaters on at 0700 and off at 1700 Monday through Friday, and turn the heaters off Saturday and Sunday:

Par 55 = 0700
Par 56 = 1700
Par 57 = - - - -
Par 58 = - - - -
Par 71 through 75 = 1
Par 76 and 77 = 0

Example 3

To turn the heaters on at 0600 each morning, go into standby for lunch at 1130, come out of standby after lunch at 1230, and turn the heaters off at 1600 at the end of the day, every day of the week:

Par 55 = 0600
Par 56 = 1600
Par 57 = 1130
Par 58 = 1230
Par 71 through 75 = 1
Par 71 through 77 = 1

Seven-day Clock *(contd)*

50 Current Day

Description:	Used to set the current day of the week.
Value:	1 to 7 (1 = Monday, 2 = Tuesday, etc.)
Resolution:	1
Default Value:	—
Format:	—
Use:	Refer to Section 4, <i>Operation, Using Melter Function Keys</i> , for information about the use and affects of the seven-day clock feature.

51 Current Hour

Description:	Used to set the local time of the day.
Value:	0000 to 2359 (European time format)
Resolution:	1 minute
Default Value:	(Time set at factory)
Format:	<i>Hours, Hour: Minute, Minute</i>
Use:	This setting only needs to be made once for all daily schedules

55 Schedule 1 Heaters On

Description:	Used to set the time that the clock will turn on the heaters during schedule 1.
Value:	0000 to 2359, - - - -
Resolution:	1 minute
Default Value:	0600
Format:	<i>Hours, Hour: Minute, Minute</i>
Use:	Set the desired time for the heaters to turn on. To disable this parameter, set the parameter's value to "- - - -" by simultaneously pressing both of the right-display scroll keys.

56 Schedule 1 Heaters Off

Description:	Used to set the time that the clock will turn off the heaters during schedule 1.
Value:	0000 to 2359, - - - -
Resolution:	1 minute
Default Value:	1700
Format:	<i>Hours, Hour: Minute, Minute</i>
Use:	To disable this parameter, set the parameter's value to "- - - -" by simultaneously pressing both of the right-display scroll keys.

57 Schedule 1 Enter Standby

Description:	Used to set the time that the melter will enter the standby mode during schedule 1.
Value:	0000 to 2359, - - - -
Resolution:	1 minute
Default Value:	- - - -
Format:	<i>Hour, Hour: Minute, Minute</i>
Use:	Set the time that the melter will enter the standby mode during schedule 1. To disable this parameter, set the parameter's value to "- - - -" by simultaneously pressing both of the right-display scroll keys. Note: Do not set an enter standby time that is outside of the time period defined by the schedule's heater on and off time. The melter cannot enter the standby mode when the heaters are off.

58 Schedule 1 Exit Standby

Description:	Used to set the time that the melter will exit the standby mode during schedule 1.
Value:	0000 to 2359, - - - -
Resolution:	1 minute
Default Value:	- - - -
Format:	<i>Hour, Hour: Minute, Minute</i>
Use:	Set the time that the melter will exit the standby mode during schedule 1. To disable this parameter, set the parameter's value to "- - - -" by simultaneously pressing both of the right-display scroll keys. Note: Do not set an exit standby time that is outside of the time period defined by the schedule's heater on and off time. The melter cannot enter the standby mode when the heaters are off.

60 Schedule 2 Heaters On

(Only available when the optional I/O card is installed)

Description:	Used to set the time that the clock will turn on the heaters during schedule 2.
Value:	0000 to 2359, - - - -
Resolution:	1 minute
Default Value:	- - - -
Format:	<i>Hours, Hour: Minute, Minute</i>
Use:	Set the desired time for the heaters to turn on. To disable this parameter, set the parameter's value to "- - - -" by simultaneously pressing both of the right-display scroll keys.

Seven-day Clock *(contd)*

61

Schedule 2 Heaters Off

(Only available when the optional I/O card is installed)

Description:	Used to set the time that the clock will turn off the heaters during schedule 2.
Value:	0000 to 2359, - - - -
Resolution:	1 e
Default Value:	- - - -
Format:	<i>Hours, Hour: Minute, Minute</i>
Use:	To disable this parameter, set the parameter's value to "- - - -" by simultaneously pressing both of the right-display scroll keys.

62

Schedule 2 Enter Standby

(Only available when the optional I/O card is installed)

Description:	Used to set the time that the melter will enter the standby mode during schedule 2.
Value:	0000 to 2359, - - - -
Resolution:	1 minute
Default Value:	- - - -
Format:	<i>Hour, Hour: Minute, Minute</i>
Use:	Set the time that the melter will enter the standby mode during schedule 2. To disable this parameter, set the parameter's value to "- - - -" by simultaneously pressing both of the right-display scroll keys. Note: Do not set an enter standby time that is outside of the time period defined by the schedule's heater on and off time. The melter cannot enter the standby mode when the heaters are off.

63

Schedule 2 Exit Standby

(Only available when the optional I/O card is installed)

Description:	Used to set the time that the melter will exit the standby mode during schedule 2.
Value:	0000 to 2359, - - - -
Resolution:	1 minute
Default Value:	- - - -
Format:	<i>Hour, Hour: Minute, Minute</i>
Use:	Set the time that the melter will exit the standby mode during schedule 2. To disable this parameter, set the parameter's value to "- - - -" by simultaneously pressing both of the right-display scroll keys. Note: Do not set an exit standby time that is outside of the time period defined by the schedule's heater on and off time. The melter cannot enter the standby mode when the heaters are off.

65**Schedule 3 Heaters On**

(Only available when the optional I/O card is installed)

Description:	Used to set the time that the clock will turn on the heaters during schedule 3.
Value:	0000 to 2359, - - - -
Resolution:	1 minute
Default Value:	- - - -
Format:	<i>Hours, Hour: Minute, Minute</i>
Use:	Set the desired time for the heaters to turn on. To disable this parameter, set the parameter's value to "- - - -" by simultaneously pressing both of the right-display scroll keys.

66**Schedule 3 Heaters Off**

(Only available when the optional I/O card is installed)

Description:	Used to set the time that the clock will turn off the heaters during schedule 3.
Value:	0000 to 2359, - - - -
Resolution:	1 minute
Default Value:	- - - -
Format:	<i>Hours, Hour: Minute, Minute</i>
Use:	To disable this parameter, set the parameter's value to "- - - -" by simultaneously pressing both of the right-display scroll keys.

67**Schedule 3 Enter Standby**

(Only available when the optional I/O card is installed)

Description:	Used to set the time that the melter will enter the standby mode during schedule 3.
Value:	0000 to 2359, - - - -
Resolution:	1 minute
Default Value:	- - - -
Format:	<i>Hour, Hour: Minute, Minute</i>
Use:	Set the time that the melter will enter the standby mode during schedule 3. To disable this parameter, set the parameter's value to "- - - -" by simultaneously pressing both of the right-display scroll keys. Note: Do not set an enter standby time that is outside of the time period defined by the schedule's heater on and off time. The melter cannot enter the standby mode when the heaters are off.

Seven-day Clock *(contd)*

68

Schedule 3 Exit Standby

(Only available when the optional I/O card is installed)

Description:	Used to set the time that the melter will exit the standby mode during schedule 3.
Value:	0000 to 2359, - - - -
Resolution:	1 minute
Default Value:	- - - -
Format:	<i>Hour, Hour: Minute, Minute</i>
Use:	Set the time that the melter will exit the standby mode during schedule 3. To disable this parameter, set the parameter's value to "- - - -" by simultaneously pressing both of the right-display scroll keys.
Note:	Do not set an exit standby time that is outside of the time period defined by the schedule's heater on and off time. The melter cannot enter the standby mode when the heaters are off.

71

Schedules for Monday

Description:	Used to select which schedule(s) should be used on Monday.
Value:	0 – Remain at last clock transition 1 – Use just schedule 1 Values 2 through 7 are only available if the optional I/O card is installed. 2 – Use just schedule 2 3 – Use just schedule 3 4 – Use schedule 1 and 2 5 – Use schedule 2 and 3 6 – Use schedule 1 and 3 7 – Use schedule 1, 2, and 3
Resolution:	1
Default Value:	0
Format:	—
Use:	Selects the active schedule(s) for the day. NOTES: If the 0 schedule option is used, the heaters will not turn on again until the next scheduled heaters on time arrives.

72 Schedules for Tuesday

Description:	Used to select which schedule(s) should be used on Tuesday.
Value:	0 – Remain at last clock transition 1 – Use just schedule 1 Values 2 through 7 are only available if the optional I/O card is installed. 2 – Use just schedule 2 3 – Use just schedule 3 4 – Use schedule 1 and 2 5 – Use schedule 2 and 3 6 – Use schedule 1 and 3 7 – Use schedule 1, 2, and 3
Resolution:	1
Default Value:	0
Format:	—
Use:	Selects the active schedule(s) for the day. NOTES: If the 0 schedule option is used, the heaters will not turn on again until the next scheduled heaters on time arrives.

73 Schedules for Wednesday

Description:	Used to select which schedule(s) should be used on Wednesday.
Value:	0 – Remain at last clock transition 1 – Use just schedule 1 Values 2 through 7 are only available if the optional I/O card is installed. 2 – Use just schedule 2 3 – Use just schedule 3 4 – Use schedule 1 and 2 5 – Use schedule 2 and 3 6 – Use schedule 1 and 3 7 – Use schedule 1, 2, and 3
Resolution:	1
Default Value:	0
Format:	—
Use:	Selects the active schedule(s) for the day. NOTES: If the 0 schedule option is used, the heaters will not turn on again until the next scheduled heaters on time arrives.

Seven-day Clock *(contd)*

74 Schedules for Thursday

Description:	Used to select which schedule(s) should be used on Thursday.
Value:	0 – Remain at last clock transition 1 – Use just schedule 1 Values 2 through 7 are only available if the optional I/O card is installed. 2 – Use just schedule 2 3 – Use just schedule 3 4 – Use schedule 1 and 2 5 – Use schedule 2 and 3 6 – Use schedule 1 and 3 7 – Use schedule 1, 2, and 3
Resolution:	1
Default Value:	0
Format:	—
Use:	Selects the active schedule(s) for the day. NOTES: If the 0 schedule option is used, the heaters will not turn on again until the next scheduled heaters on time arrives.

75 Schedules for Friday

Description:	Used to select which schedule(s) should be used on Friday.
Value:	0 – Remain at last clock transition 1 – Use just schedule 1 Values 2 through 7 are only available if the optional I/O card is installed. 2 – Use just schedule 2 3 – Use just schedule 3 4 – Use schedule 1 and 2 5 – Use schedule 2 and 3 6 – Use schedule 1 and 3 7 – Use schedule 1, 2, and 3
Resolution:	1
Default Value:	0
Format:	—
Use:	Selects the active schedule(s) for the day. NOTES: If the 0 schedule option is used, the heaters will not turn on again until the next scheduled heaters on time arrives.

76 Schedules for Saturday

Description:	Used to select which schedule(s) should be used on Saturday.
Value:	0 – Remain at last clock transition 1 – Use just schedule 1 2 – Use just schedule 2 3 – Use just schedule 3 4 – Use schedule 1 and 2 5 – Use schedule 2 and 3 6 – Use schedule 1 and 3 7 – Use schedule 1, 2, and 3
Resolution:	1
Default Value:	0
Format:	—
Use:	Selects the active schedule(s) for the day. NOTES: If the 0 schedule option is used, the heaters will not turn on again until the next scheduled heaters on time arrives.

77 Schedules for Sunday

Description:	Used to select which schedule(s) should be used on Sunday.
Value:	0 – Remain at last clock transition 1 – Use just schedule 1 Values 2 through 7 are only available if the optional I/O card is installed. 2 – Use just schedule 2 3 – Use just schedule 3 4 – Use schedule 1 and 2 5 – Use schedule 2 and 3 6 – Use schedule 1 and 3 7 – Use schedule 1, 2, and 3
Resolution:	1
Default Value:	0
Format:	—
Use:	Selects the active schedule(s) for the day. NOTES: If the 0 schedule option is used, the heaters will not turn on again until the next scheduled heaters on time arrives.

This page intentionally left blank.

Appendix C

400/480 Volt Mesa Adhesive Melters



WARNING: Allow only personnel with appropriate training and experience to operate or service the equipment. The use of untrained or inexperienced personnel to operate or service the equipment can result in injury, including death, to themselves and others, and damage to the equipment.

This appendix provides information about the 400/480 volt versions of the Mesa adhesive melter. Key information provided in this appendix which does not appear in the body of this manual includes:

- Installation instructions specific to the 400/480 volt melters and transformers
- Transformer sizing guidance
- Transformer troubleshooting

For setup, operation, troubleshooting, and parts information that is common to all Mesa adhesive melters, refer to the appropriate section of this manual.

Introduction

Safety

Before installing or operating the transformer or melter, read the safety information provided in Section 1, *Safety*.

Intended Use

- The 1.5 kVA and 3.0 kVA transformers can only be used with Mesa adhesive melters that are specifically designed for 400/480 volt electrical service.
- Use an input electrical service rated at 400 volts 3-phase without a neutral or 480 volts 3-phase without a neutral.

Unintended Use

- Water wash-down environments
- Explosive atmospheres

Transformer Sizing

Review the following transformer sizing procedure to ensure that your transformer is correctly sized for the number and type of hoses/guns you intend to use.

To size your transformer

1. Determine the total power consumption (in watts) at 230 volts for all of your hoses and guns. Table C-1 lists the wattages of common hoses and guns that are sold by Nordson Corporation. If your hose or gun is not listed in Table C-1, refer to the identification tag that is affixed to the hose/gun.
2. Calculate the kVA rating of the required transformer by dividing the total wattage calculated in step 1 by 1000.

Example

From Table C-1, an application requires two 1.8 m auto hoses at 155 W each and two H-402 (T-LP) guns at 185 W each.

The combined wattage of the selected hoses and guns is 680 W.

$$680 \div 1000 = \mathbf{0.68 \text{ kVA}}$$

In this example, the 1.5 kVA transformer would be adequate.

Table C-1 Hose and Gun Power Consumption

Hose/Gun	Wattage (230 Volts)
<i>Hoses</i>	
Auto hose 0.6 m (2 ft.)	45
Auto hose 1.2 m (4 ft.)	100
Auto hose 1.8 m (6 ft.)	155
Auto hose 2.4 m (8 ft.)	205
Auto hose 3 m (10 ft.)	265
Auto hose 3.6 m (12 ft.)	315
Auto hose 4.8 m (16 ft.)	420
Auto hose 7.2 m (24 ft.)	635
Manual hose 2.4 m (8 ft.)	205
Manual hose 4.8 m (16 ft.)	420
<i>Guns</i>	
H-201 or 401 (T or T-L)	140
H-202 or 402 (T or T-L)	210
H-204 or 404 (T or T-L)	260
H-208 or 408 (T or T-L)	405
H-202 or 402 (T-E or T-E-L)	335
H-204 or 404 (T-E or T-E-L)	350
H-202 or 402 (T-LP or T-LP-L)	185
H-204 or 404 (T-LP or T-LP-L)	285
H-208 or 408 (T-LP or T-LP-L)	390
H-20 (T or T-L0)	135
H-20 w/micro (T)	160

Transformer Base Function

Input electrical service of 400 or 480 volts is split between the melter heaters and the transformer(s). The melter's tank heater operates on line voltage, which is passed through the transformer base to the melter using a special wire harness. The melter's CPU controls the duty cycle of the heaters. No change in melter programming is required in order for the transformer base to operate.

The transformer base reduces the input electrical service to 230 volts and directs the reduced voltage to the melter's expansion board. The main circuit board uses this voltage to power the hoses and guns and provide control power to the CPU.

CPU-generated control signals are fed to a driver board in the transformer base, which uses high-power TRIACs to switch power to the tank heater.

Installation

Before installing the transformer base, familiarize yourself with Section 3, *Installation*.

NOTE: Mesa 400/480 volt transformer bases can only be used in conjunction with Mesa adhesive melters that are specifically designed for use with 400/480 volt electrical service.

Clearances

Figure C-1 illustrates the *minimum* clearances that are required between the melter and surrounding objects. Table C-2 describes each clearance.

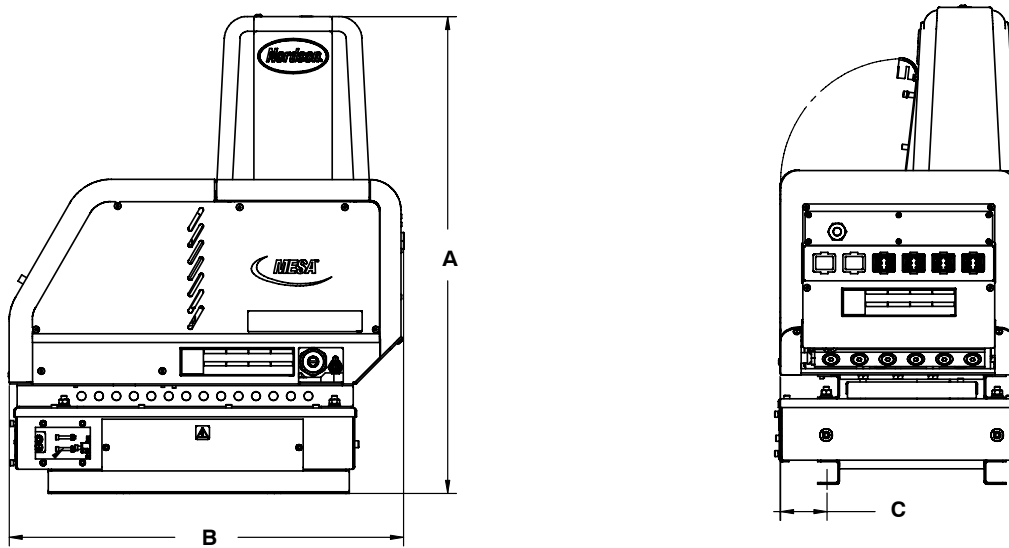

Figure C-1 Minimum installation clearances

Table C-2 Installation Clearances

Item	Description	Required Clearance
A	Height from bottom of transformer base to the top of the pump cover	693.93 mm (27.32 in.)
B	Melter width from the front of the electrical enclosure to the face of the hose connection panel	Mesa 4 = 573.82 mm (22.59 in.) Mesa 6 = 625.60 mm (24.63 in.) Mesa 9 = 690.63 mm (27.19 in.)
C	Center of the transformer base mounting hole to the face of the melter side panel	67.52 mm (2.66 in.)

400/480 Volt Melter Weights

Table C-3 lists the empty weight (no adhesive) of each Mesa 400/480 volt melter with a transformer base.

Table C-3 400/480 Volt Melter Weights

Melter	Weight
Mesa 4, 2H/G	60.8 kg (133.9 lb)
Mesa 4, 4H/G	69.8 kg (153.9 lb)
Mesa 6, 2H/G	63.8 kg (139.9 lb)
Mesa 6, 4H/G	72.5 kg (159.9 lb)
Mesa 9, 4H/G	74.1 kg (163.4 lb)

Installation Kit Components

The following components are shipped with the transformer base.

NOTE: These components are in addition to the components that are provided in the melter installation kit.

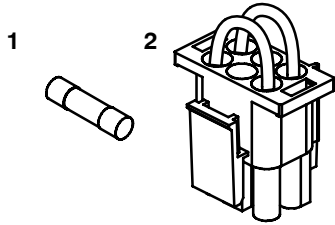

Figure C-2 Transformer base installation kit

1. Fuse, 12A, 600V fast acting, P/N 1083597 (spare)
2. Voltage plug, 480 volt, P/N 1039790

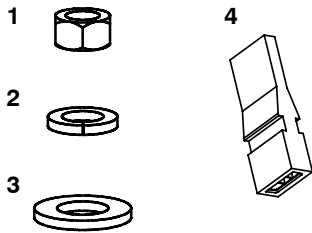

Figure C-3 Mesa 400/480V melters installation kit

1. M8 hex nut
2. M8 lock washer
3. M8 flat washer
4. Configuration jumper P/N 171856

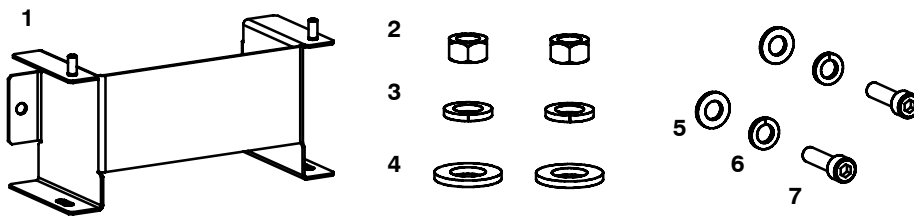

Figure C-4 Mesa 6 and 9 support leg kit

1. Support leg (Mesa 6 and 9 only)
2. M8 hex nut
3. M8 lock washer
4. M8 flat washer
5. M6 cap screw
6. M6 lock washer
7. M6 flat washer

Prepare the Transformer Base for Installation

See Figure C-5.

1. Remove the lid from the transformer base (A).

NOTE: There is a ground lead running between the lid and the transformer base.

2. (Optional) For 480 volt operation, remove the 400 VAC voltage plug from the transformer base circuit board and replace it with the 480 VAC voltage plug (B) provided with the transformer base.

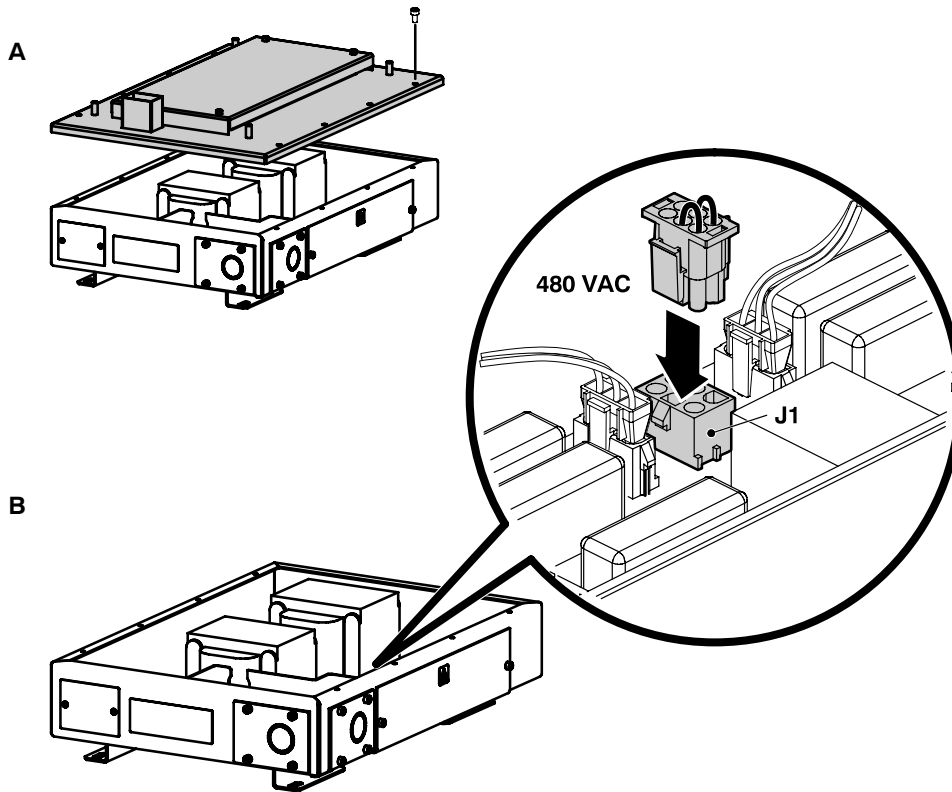

Figure C-5 Preparing the transformer base

Connect the Electrical Service to the Transformer Base

1. Select a 3-wire (plus ground) power cable rated for the maximum amperage required by the melter. Ensure that the power cable meets applicable electrical codes and standards. Table C-4 lists the maximum amperages (per line) for 400/480 volt Mesa adhesive melters.

Table C-4 Maximum Melter Amperages

Transformer	400 VAC	480 VAC
1.5 kVA	8 A	9A
3.0 kVA	13A	14A



WARNING: Risk of electrocution! Mesa melters must be installed with a lockable power disconnect switch that completely de-energizes the melter by isolating it from its power source. Failure to de-energize the melter when required can result in personal injury, including death.



WARNING: Risk of electrical shock or short circuit. Use rigid or flexible conduit or an appropriately sized strain relief to protect the power cable from the sharp edge of the conduit knockout.

2. Route the power cable between the power disconnect switch and the transformer base. Standard conduit penetrations are provided on the bottom and side of the transformer base. Secure the power cable to the transformer base using a suitable strain relief.

See Figure C-6.

3. Connect the power cable to the terminal block (terminals 1, 2, and 3).
4. Connect the power cable ground lead to the ground lug.

See Figure C-7.

5. Route the transformer base cable harness through the penetration in the lid. Ensure that all six connectors are passed through the penetration.
6. Replace and secure the transformer lid.

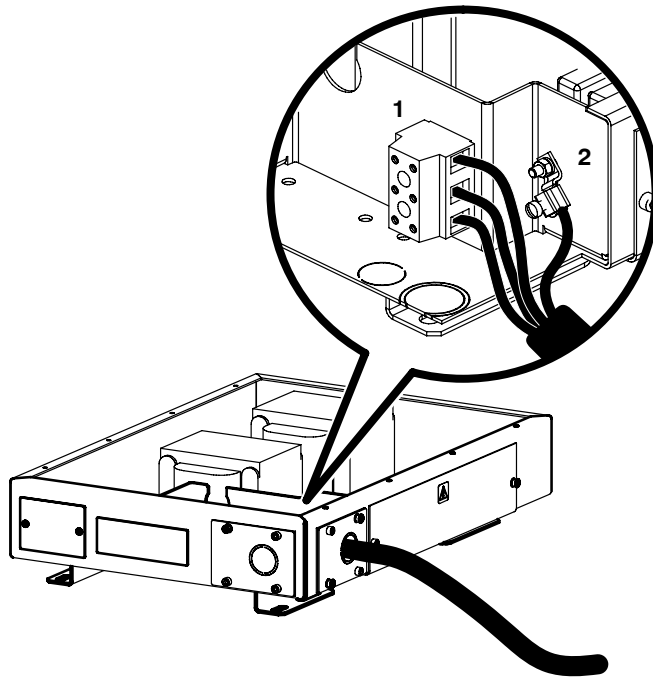

Figure C-6 Connecting the electrical service

1. Terminal block
2. Ground lug

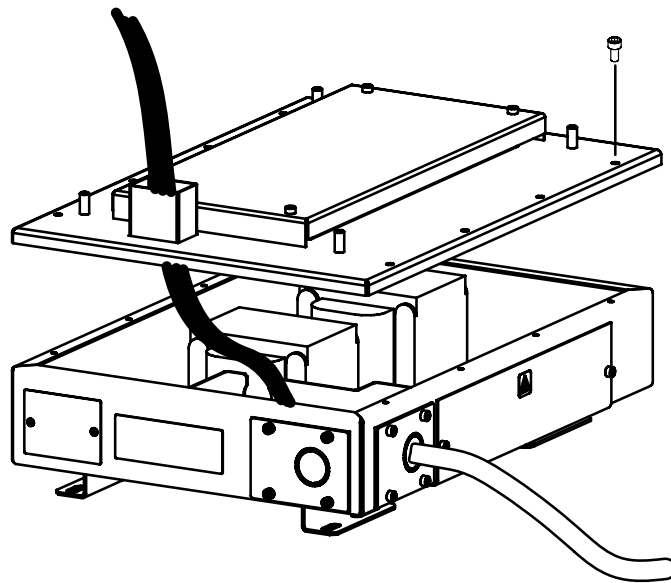

Figure C-7 Routing the cable harness through the lid

Attach the Support Leg (Mesa 6 and 9 only)

See Figure C-8.

1. Remove the two screws from the end of the transformer base. Dispose of these screws.
2. Using the two sets of M6 screws and washers provided with the support leg, attach the support leg to the end of the transformer base.

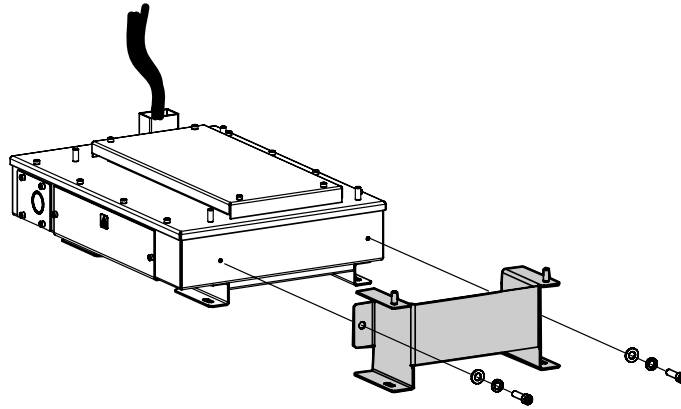

Figure C-8 Attaching the support leg to the transformer base

Mount the Transformer Base on the Parent Machine

NOTE: The transformer base can be mounted directly on any parent machine that is already configured for mounting either a model 3100V or a model 3400V adhesive melter.

See Figure C-9.

The Mesa 4 transformer base uses a four-hole bolt mounting pattern. Mesa 6 and 9 melters require two additional mounting holes for the support leg.

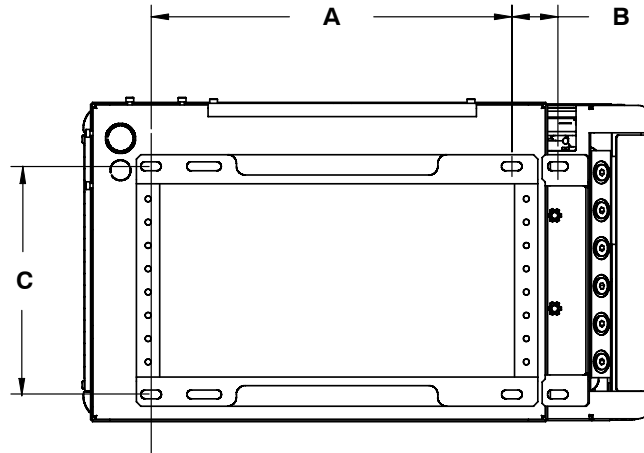

Figure C-9 Transformer bolt mounting pattern

Table C-5 Transformer Base Bolt Pattern Dimensions

Item	Dimension
A	394.00 mm (15.50 in.)
B	Mesa 4 = Not applicable Mesa 6 = 50.29 mm (1.98 in.) Mesa 9 = 116.33 mm (4.58 in.)
C	249.07 mm (9.81 in.)

Mount the Melter on the Transformer

See Figure C-10.

1. Route the cable harness from the transformer base up through the penetration (A) in the floor of the electrical enclosure.

CAUTION: Ensure that the cable harness is not pinched between the transformer and the melter.

2. Set the melter down onto the transformer base so that the studs on the transformer lid (and support leg if used) mate with the holes in the melter base.
3. Secure the melter to the transformer base using the four M8 nuts and washers (B) provided in the installation kit.

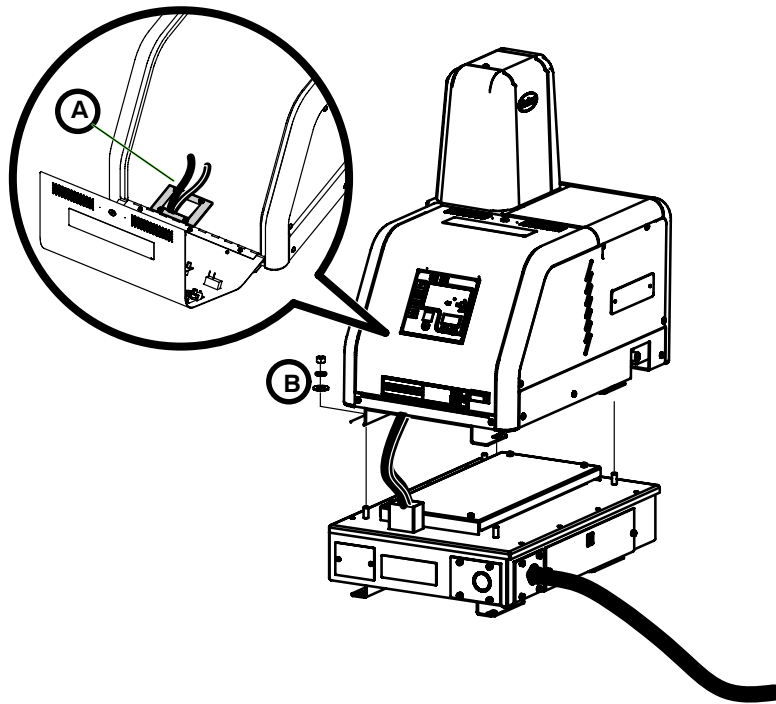

Figure C-10 Mounting the melter on the transformer base

Connect the Transformer to the Melter

See Figure C-11.

Connect each plug on the cable harness to the melter.

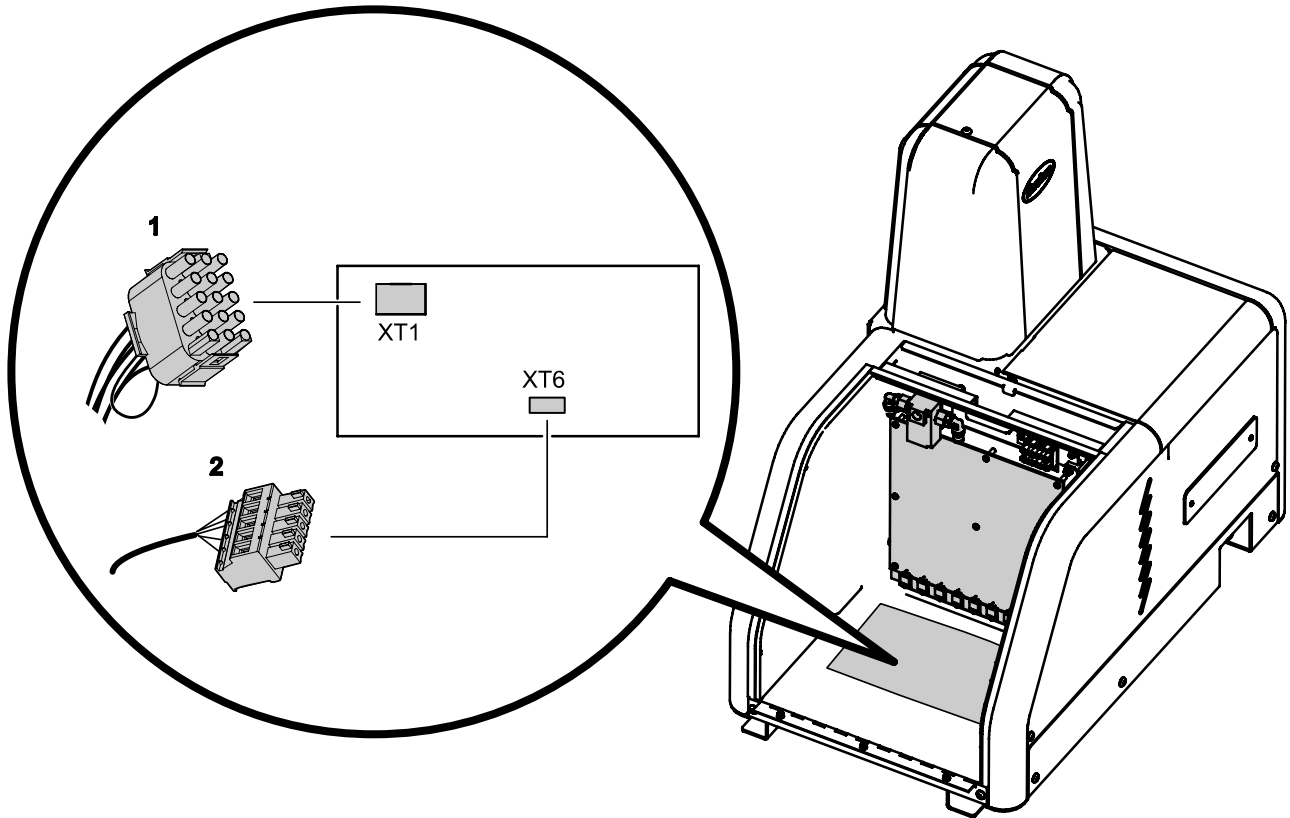

Figure C-11 Connecting the transformer base cable harness to the melter

1. Power to expansion board
2. Tank heater/relay control signal

Install the Configuration Jumper (480 VAC melter only)

See Figure C-12.

To enable 480 volt operation, the configuration jumper provided in the melter installation kit must be installed across pins 5 and 6 of terminal JP1 on the main printed circuit board.

CAUTION: Failure to properly install the configuration jumper may result in reduced tank heater life or damage to the melter.

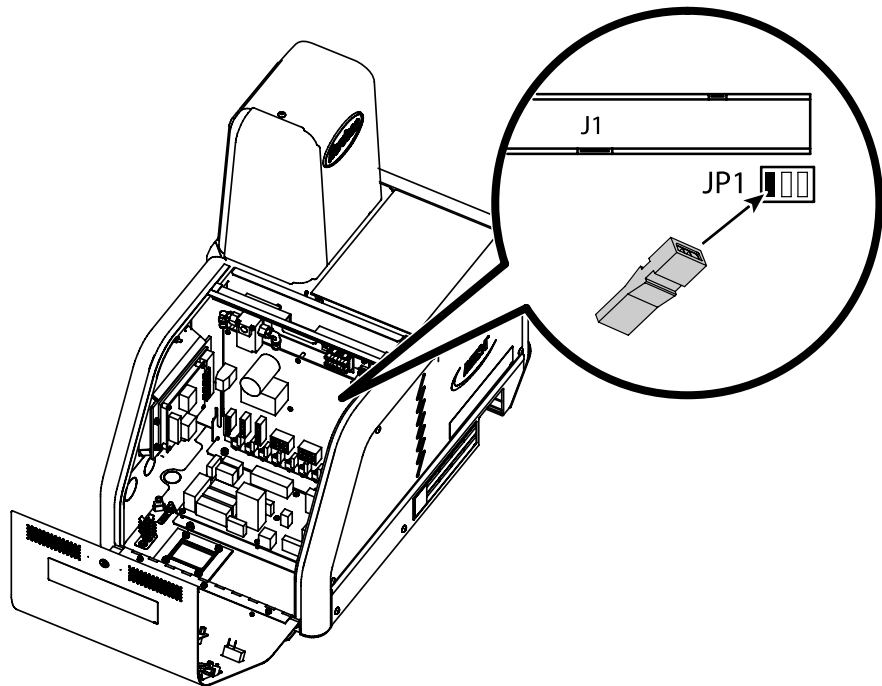

Figure C-12 Installing the 480 VAC configuration jumper

Operation

Refer Section 4, *Operation*, for information about using the melter.

Troubleshooting

The following table provides transformer-specific troubleshooting guidance. Refer to the Section 6, *Troubleshooting* for general melter troubleshooting information.

Problem	Possible Cause	Corrective Action
1. No power to melter	Problem with customer power source No voltage plug installed Loose/disconnected cables Blown fuse Problem with transformer	Check all three phases at terminal block Install correct voltage plug Check cable between transformer and X1 on the expansion board Check connections between transformer service terminal block and J2 on power distribution module Check fuses F3, F4, F5, and F6 Check voltage into primary of transformer(s) and voltage at secondaries
2. Tank not heating, but power to melter	Programming/control issue Loose/disconnected cables Problem with tank heater Blown fuse Power problem Problem with power distribution module	Turn heaters on/check that tank setpoint is correct (not 0) Check connection at XT5 and XT6 on the expansion board Check connections along heater harness (intermediate connections, terminals of heaters, connection back to J3 on power distribution module) Check for open or short. Cold resistance values are: M4 – 195 to 227 ohms M6 – 130 to 152 ohms M9 – 93 to 109 ohms Check F1/F2 on power distribution module Check all three phases at terminal block Replace module
3. Fuse(s) fail frequently	F1 or F2 fault: short circuit in heater or harness F3, F4, F5, or F6: Transformer is overloaded	Locate and correct short Verify that total hose/gun power does not exceed capability of transformer
4. F3 fault on tank	Shorted TRIAC(s) Noise problem	Replace power distribution module Isolate sources of noise, change phases of incoming supply, or add filter/snubber to incoming supply line

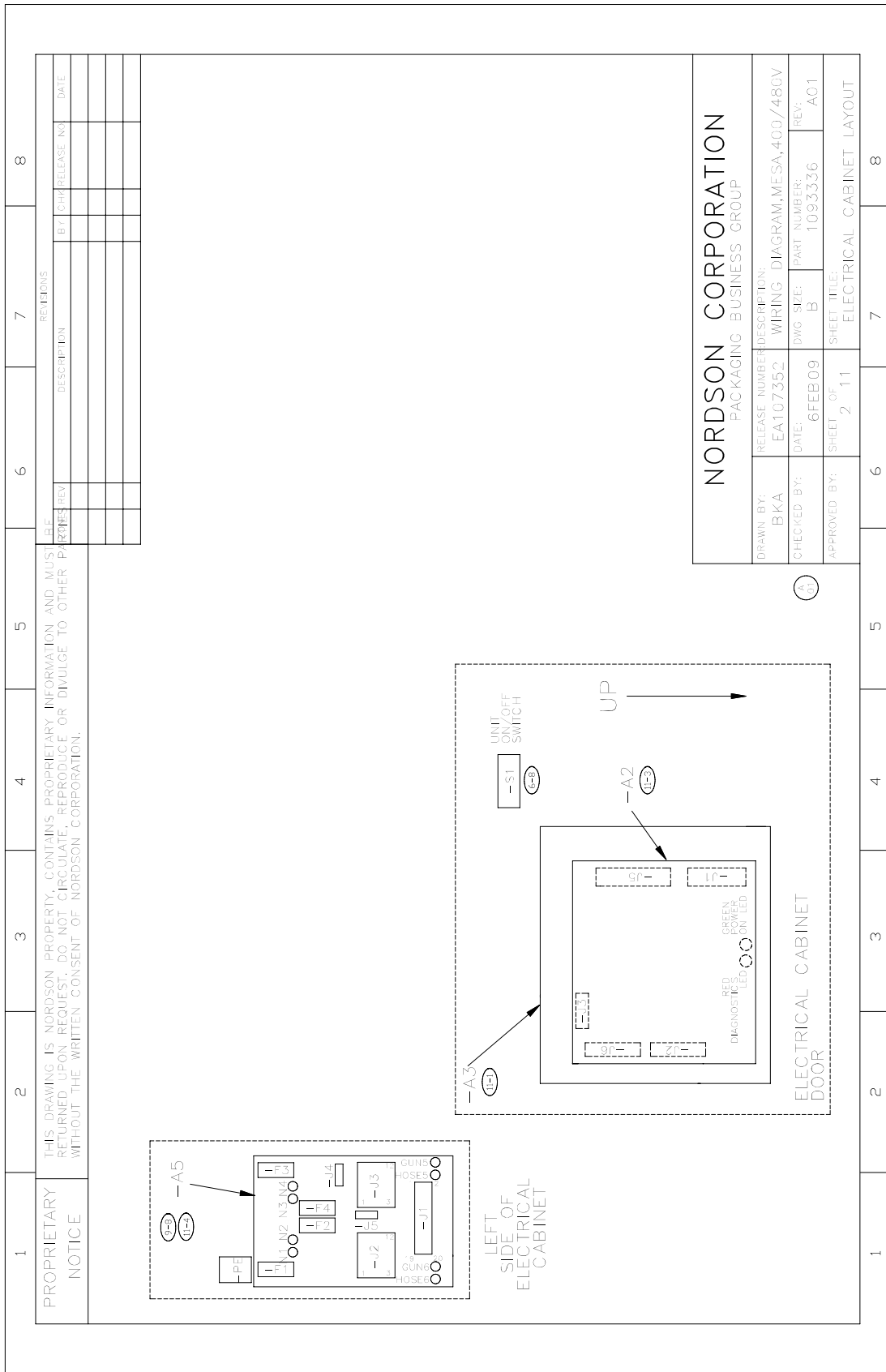

1	2	3	4	5	6	7	8																																											
<p style="text-align: center;">PROPRIETARY NOTICE</p> <p style="text-align: center;">THIS DRAWING IS NORDSON PROPERTY; CONTAINS PROPRIETARY INFORMATION AND MUST BE RETURNED UPON REQUEST. DO NOT CIRCULATE, REPRODUCE OR DIVULGE TO OTHER PERSONS WITHOUT THE WRITTEN CONSENT OF NORDSON CORPORATION.</p>				<p style="text-align: center;">REVOLUTIONS</p> <table border="1" style="width: 100%; border-collapse: collapse;"> <thead> <tr> <th style="width: 10%;">REV</th> <th style="width: 50%;">DESCRIPTION</th> <th style="width: 10%;">BY</th> <th style="width: 10%;">DATE</th> </tr> </thead> <tbody> <tr><td> </td><td> </td><td> </td><td> </td></tr> <tr><td> </td><td> </td><td> </td><td> </td></tr> <tr><td> </td><td> </td><td> </td><td> </td></tr> <tr><td> </td><td> </td><td> </td><td> </td></tr> </tbody> </table>				REV	DESCRIPTION	BY	DATE																																							
REV	DESCRIPTION	BY	DATE																																															
<div style="border: 1px dashed black; padding: 20px; width: fit-content; margin: auto;"> <p style="text-align: center;">HOSE/GUN PANEL LAYOUT (EXTERIOR VIEW)</p> </div>																																																		
<p>KEY:</p> <p>-HC 1, -HC 2, -HC 3, -HC 4 = HOSE/GUN CONNECTORS</p> <p>4 = SHEET-ZONE WHERE ITEM IS SHOWN</p>																																																		
<table border="1" style="width: 100%; border-collapse: collapse;"> <tr> <td colspan="8" style="text-align: center;">NORDSON CORPORATION</td> </tr> <tr> <td colspan="8" style="text-align: center;">PAC KAGING BUSINESS GROUP</td> </tr> <tr> <td style="width: 20%;">DRAWN BY:</td> <td style="width: 20%;">BKA</td> <td style="width: 20%;">RELEASE NUMBER:</td> <td colspan="3" style="width: 30%;">EA107352</td> <td colspan="3" style="width: 20%;">DESCRIPTION: WIRING DIAGRAM, MESA, 400/480V</td> </tr> <tr> <td>CHECKED BY:</td> <td>6FEB09</td> <td>DATE:</td> <td>DWG SIZE:</td> <td>B</td> <td>PART NUMBER:</td> <td>1093336</td> <td>REV:</td> <td>A01</td> </tr> <tr> <td>APPROVED BY:</td> <td>4</td> <td>SHEET OF:</td> <td>3</td> <td>11</td> <td colspan="3">SHEET TITLE:</td> <td>HOSE/GUN PANEL LAYOUT</td> </tr> </table>								NORDSON CORPORATION								PAC KAGING BUSINESS GROUP								DRAWN BY:	BKA	RELEASE NUMBER:	EA107352			DESCRIPTION: WIRING DIAGRAM, MESA, 400/480V			CHECKED BY:	6FEB09	DATE:	DWG SIZE:	B	PART NUMBER:	1093336	REV:	A01	APPROVED BY:	4	SHEET OF:	3	11	SHEET TITLE:			HOSE/GUN PANEL LAYOUT
NORDSON CORPORATION																																																		
PAC KAGING BUSINESS GROUP																																																		
DRAWN BY:	BKA	RELEASE NUMBER:	EA107352			DESCRIPTION: WIRING DIAGRAM, MESA, 400/480V																																												
CHECKED BY:	6FEB09	DATE:	DWG SIZE:	B	PART NUMBER:	1093336	REV:	A01																																										
APPROVED BY:	4	SHEET OF:	3	11	SHEET TITLE:			HOSE/GUN PANEL LAYOUT																																										
1	2	3	4	5	6	7	8																																											

1	2	3	4	5	6	7	8																												
<p>PROPRIETARY NOTICE</p> <p>THIS DRAWING IS NORDSON PROPERTY; CONTAINS PROPRIETARY INFORMATION AND MUST BE RETURNED UPON REQUEST. DO NOT CIRCULATE, REPRODUCE OR DIVULGE TO OTHER PARTIES WITHOUT THE WRITTEN CONSENT OF NORDSON CORPORATION.</p>				<p style="text-align: center;">REVOLUTIONS</p> <table border="1" style="width: 100%; border-collapse: collapse;"> <thead> <tr> <th style="width: 10%;">REV</th> <th style="width: 50%;">DESCRIPTION</th> <th style="width: 10%;">BY</th> <th style="width: 10%;">DATE</th> </tr> </thead> <tbody> <tr><td> </td><td> </td><td> </td><td> </td></tr> <tr><td> </td><td> </td><td> </td><td> </td></tr> <tr><td> </td><td> </td><td> </td><td> </td></tr> <tr><td> </td><td> </td><td> </td><td> </td></tr> <tr><td> </td><td> </td><td> </td><td> </td></tr> </tbody> </table>				REV	DESCRIPTION	BY	DATE																					<p style="text-align: center;">LIST OF DRAWINGS:</p> <p>PAGE 1: ELECTRICAL CABINET LAYOUT PAGE 2: ELECTRICAL CABINET LAYOUT PAGE 3: HOSE/GUN PANEL LAYOUT PAGE 4: LIST OF DRAWINGS PAGE 5: INPUT POWER PAGE 6: CTRL SIGS, TANK RTD, THST, SOL PAGE 7: TANK HEATER POWER PAGE 8: HOSES/GUNS 1&2 PAGE 9: HOSES/GUNS 3&4 PAGE 10: INPUTS/OUTPUTS PAGE 11: RIBBON CABLES, MISC. GROUNDS</p>			
REV	DESCRIPTION	BY	DATE																																
<p>NORDSON CORPORATION PAC KAGING BUSINESS GROUP</p> <table border="1" style="width: 100%; border-collapse: collapse;"> <tr> <td style="width: 25%;">DRAWN BY: BKA</td> <td style="width: 25%;">RELEASE NUMBER/DESCRIPTION: EA107352 WIRING DIAGRAM, MESA, 400/480V</td> <td style="width: 25%;">DATE: 6FEB09</td> <td style="width: 25%;">DWG SIZE: B</td> </tr> <tr> <td>CHECKED BY:</td> <td>PART NUMBER: 1093336</td> <td>REV: A01</td> <td></td> </tr> <tr> <td>APPROVED BY:</td> <td>SHEET OF 4 11</td> <td colspan="2">LIST OF DRAWINGS</td> </tr> </table>								DRAWN BY: BKA	RELEASE NUMBER/DESCRIPTION: EA107352 WIRING DIAGRAM, MESA, 400/480V	DATE: 6FEB09	DWG SIZE: B	CHECKED BY:	PART NUMBER: 1093336	REV: A01		APPROVED BY:	SHEET OF 4 11	LIST OF DRAWINGS																	
DRAWN BY: BKA	RELEASE NUMBER/DESCRIPTION: EA107352 WIRING DIAGRAM, MESA, 400/480V	DATE: 6FEB09	DWG SIZE: B																																
CHECKED BY:	PART NUMBER: 1093336	REV: A01																																	
APPROVED BY:	SHEET OF 4 11	LIST OF DRAWINGS																																	
1	2	3	4	5	6	7	8																												

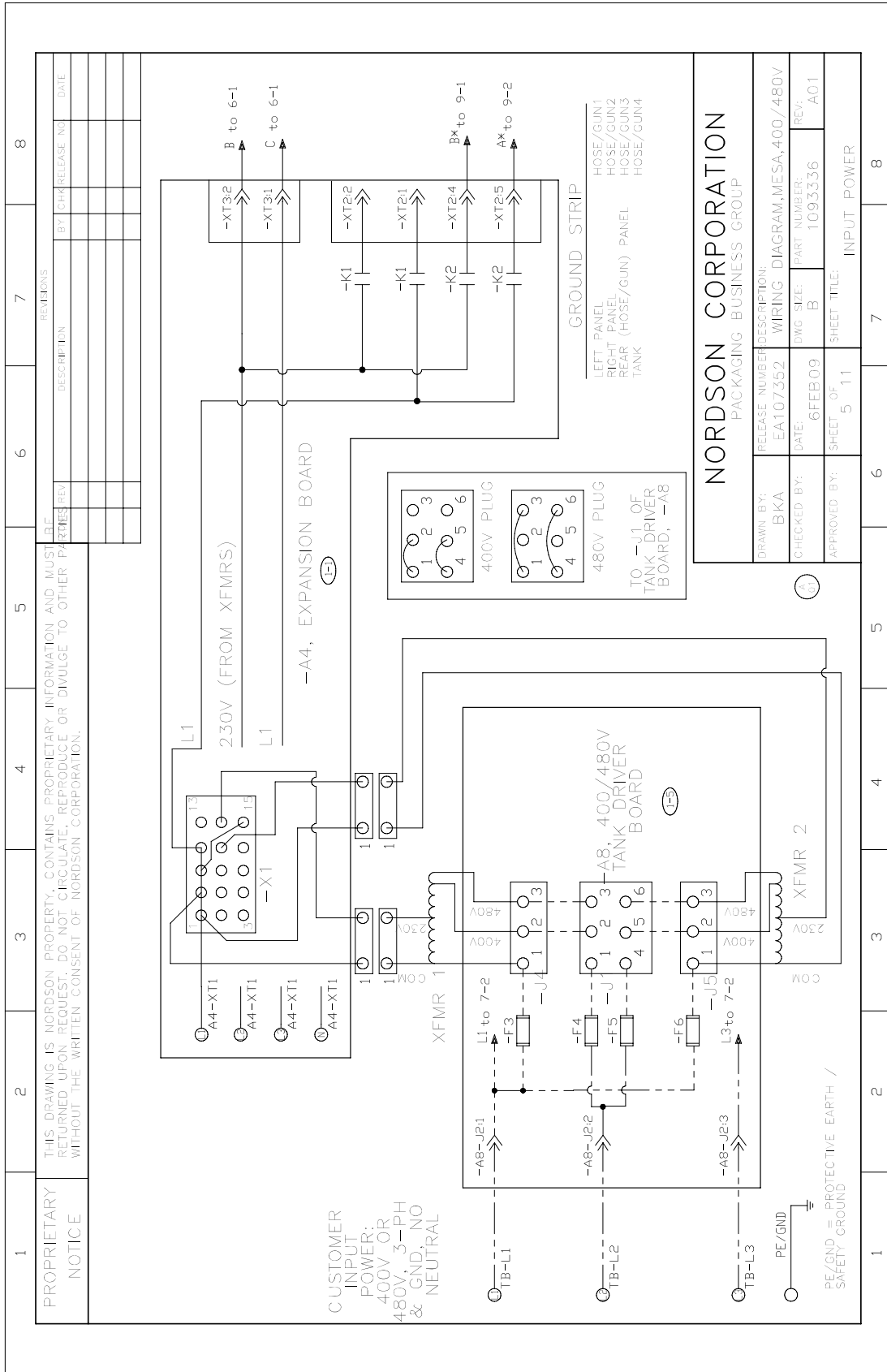

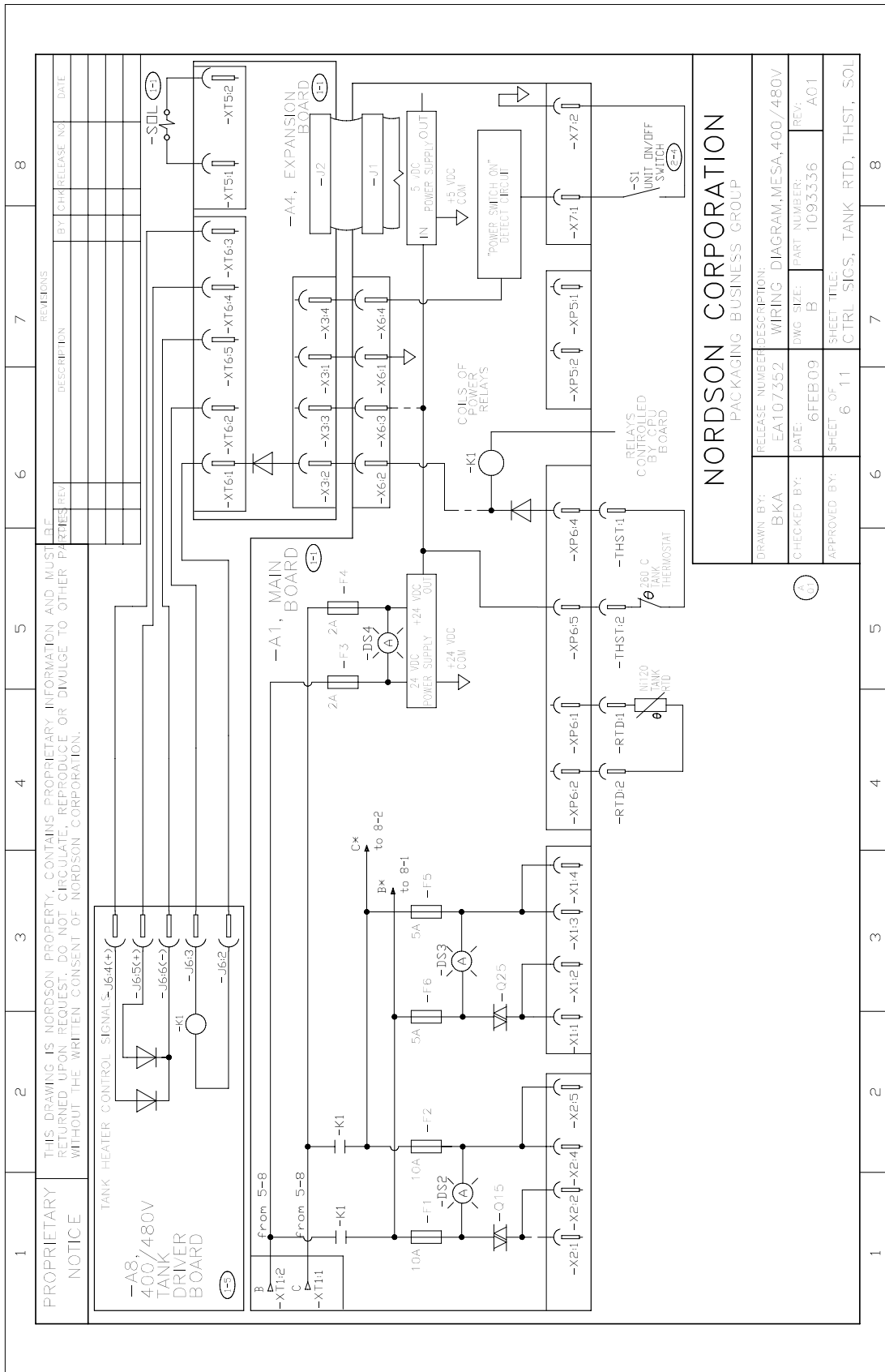

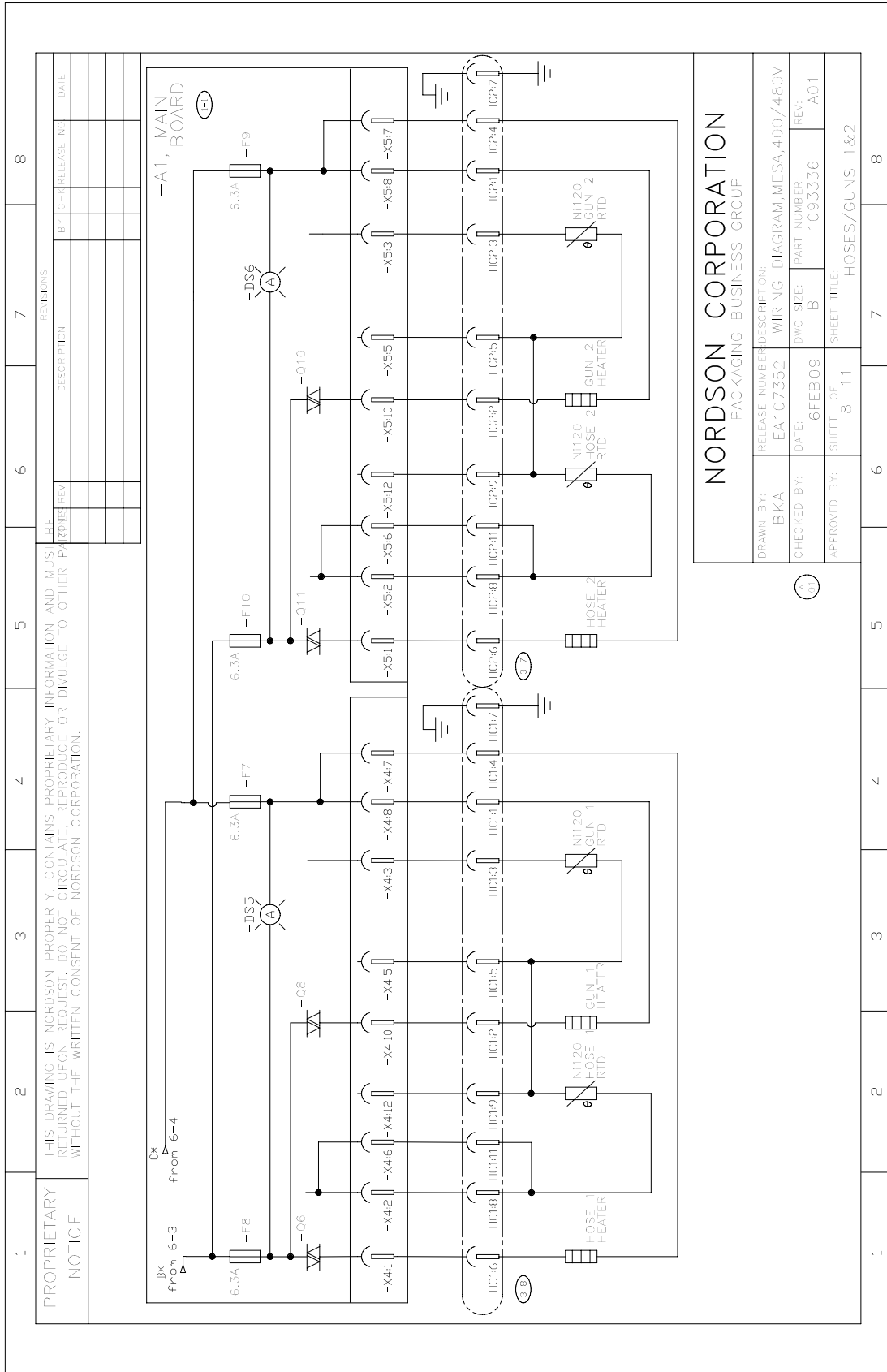

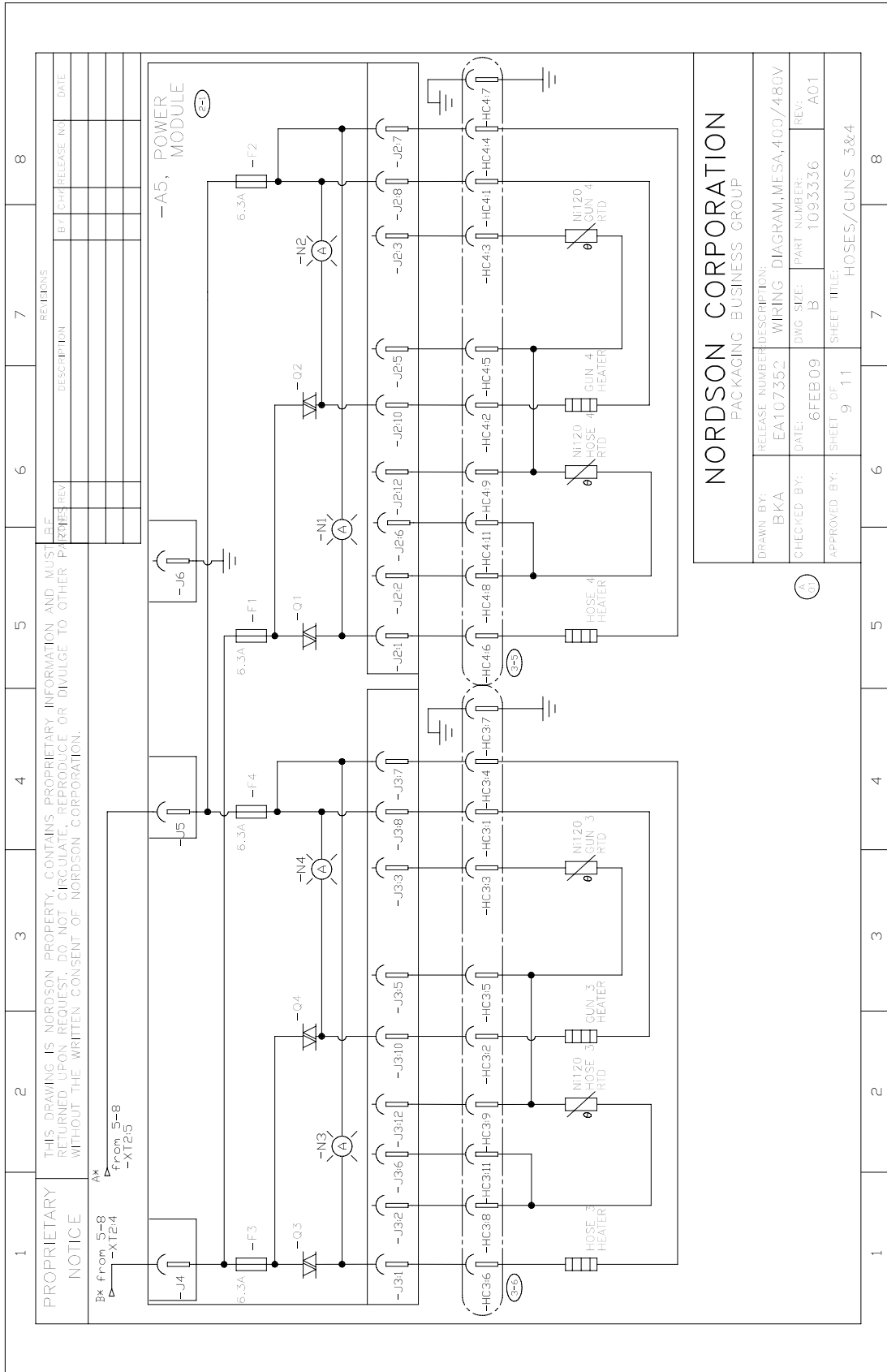

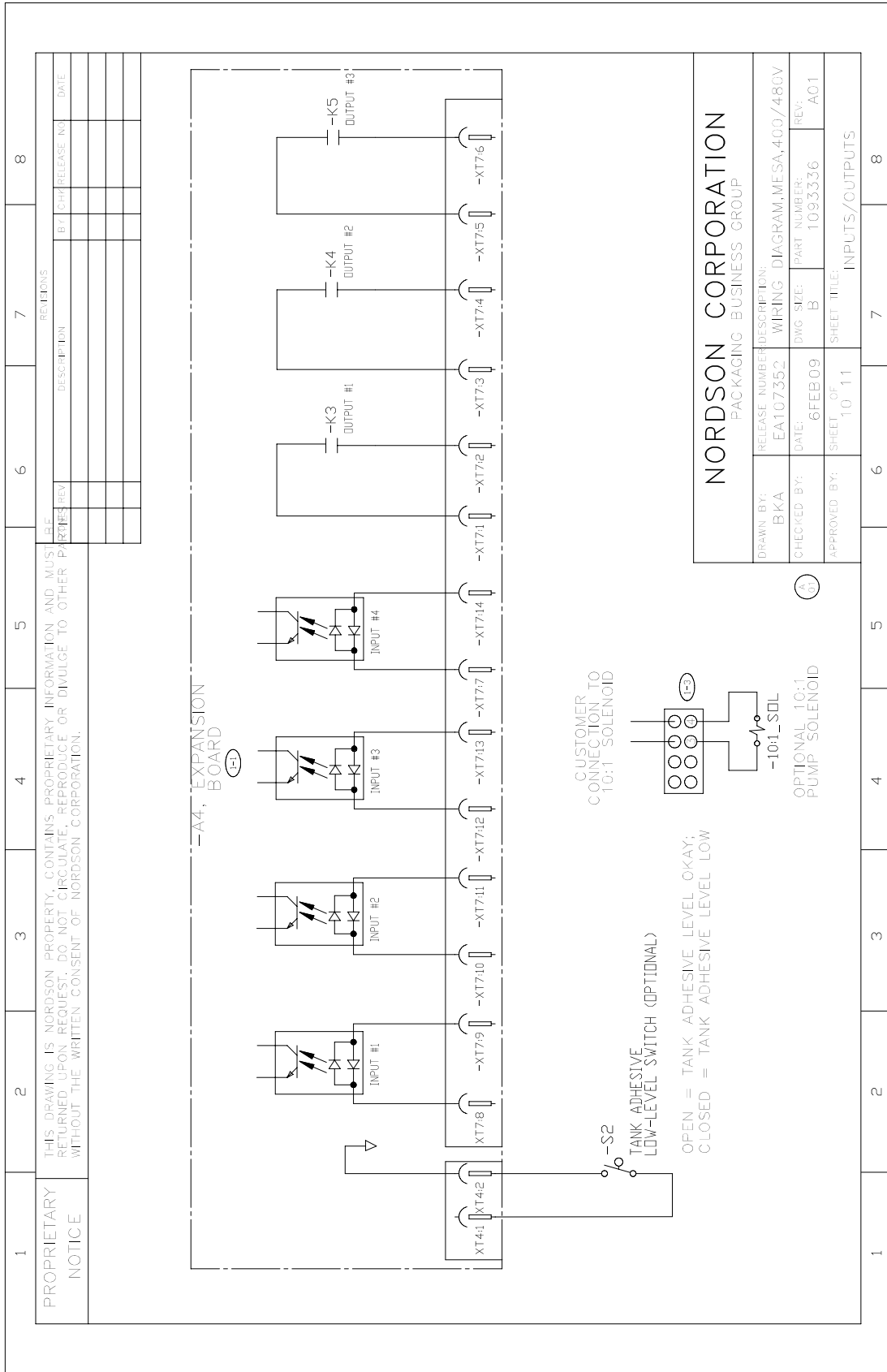

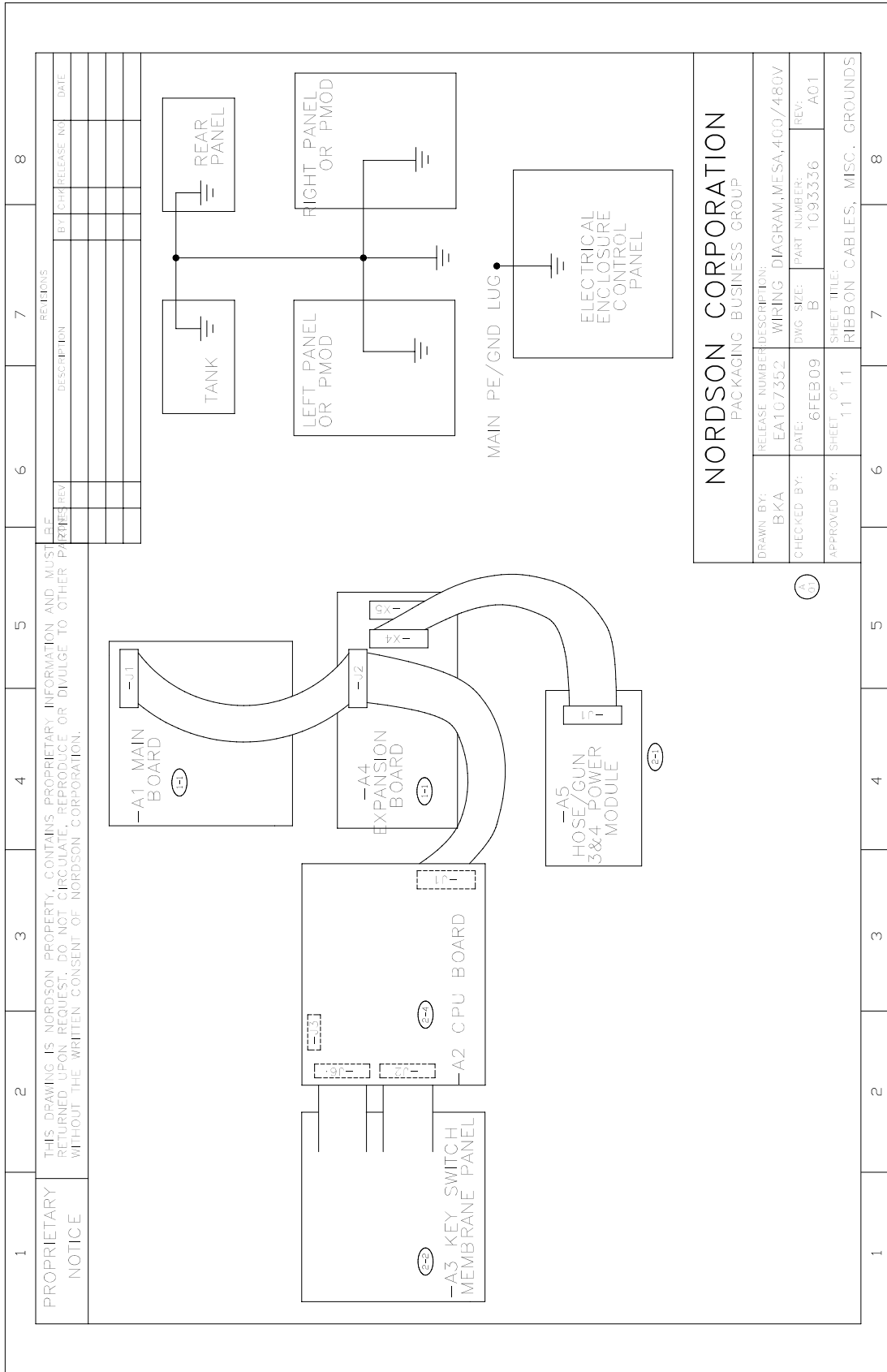

This page intentionally left blank.

EC Declaration of Conformity
*for Adhesive and Sealant Application Equipment
conforming to European Council Directives*



PRODUCT:

Mesa™ Melters, Models M4, M6, M9, and M14

APPLICABLE DIRECTIVES:

Machinery Directive: 2006/42/EC

Low Voltage Directive: 2006/95/EC

Electromagnetic Compatibility Directive: 2004/108/EC

STANDARDS USED TO VERIFY COMPLIANCE:

EN ISO 12100 EN 60204-1

EN ISO 13732-1 EN 61000-6-2

EN 55011

PRINCIPLES:

This product has been manufactured according to good engineering practice.

The product specified conforms to the directives and standards described above.

A handwritten signature in blue ink that reads 'Peter Lambert' is positioned above a horizontal line.

Peter Lambert, Vice President
Adhesives Dispensing Systems

Technical File Contact:
Dieter Ziesmer
Nordson Engineering GmbH
Lilienthalstrasse 30
21337 Lueneburg
GERMANY

Date: 15/February/2010



Nordson Corporation • 28601 Clemens Road • Westlake, Ohio